

STB Self-Checking Optical Touch Buttons



Instruction Manual



- Continuous internal self-checking operation
- Diverse-redundant microcontroller-based photoelectric touch buttons
- Ergonomically designed to eliminate hand, wrist, and arm stresses associated with repeated switch operation; requires no physical pressure to operate
- High excess gain cuts through heavy contamination
- Immune to ambient light, EMI, and RFI interference
- LED power, output, and fault indicators
- Pre-installed field covers protect the device and prevent inadvertent activation



WARNING:

Not a Stand-Alone Safety Device. STB Series Touch Buttons are self-checking ergonomic actuating devices, but are not, by themselves, safety devices. To be used in a safety application, two STBs must be interfaced with a type IIIC two-hand-control module, such as the Banner AT-FM-10K, to meet all relevant safety requirements of the appropriate standards (for example, ISO13851 / EN574).

Models

Model	Cable	Supply Voltage	Output Type	DUO-TOUCH® SG Compatibility
STBVP6	4-wire 2 m (6.5 ft) integral cable	10 V DC to 30 V DC	Complementary PNP	AT-FM-10K and AT-GM/HM-13A Two-Hand Control Modules, XS/SC26-2 Safety Controllers, and SC10-2 Safety Controller
STBVP6Q	4-Pin Mini-style Quick Disconnect			
STBVP6Q5	4-Pin Euro-style Quick Disconnect			
STBVR81	5-wire 2 m (6.5 ft) integral cable	20 V AC/DC to 30 V AC/DC	Two Individual Complementary Relays	
STBVR81Q	5-Pin Mini-style Quick Disconnect			
STBVR81Q6	5-Pin Euro-style Quick Disconnect			

To order the 9 m (30 ft) cable models, add the suffix "W/30" to the cabled model number. For example, STBVP6 W/30. Models with a quick disconnect connector require a mating cable.

Important - Read This Before Proceeding

The user is responsible for satisfying all local, state, and national laws, rules, codes, and regulations relating to the use of this product and its application. Banner Engineering Corp. has made every effort to provide complete application, installation, operation, and maintenance instructions. Please contact a Banner Applications Engineer with any questions regarding this product.

The user is responsible for making sure that all machine operators, maintenance personnel, electricians, and supervisors are thoroughly familiar with and understand all instructions regarding the installation, maintenance, and use of this product, and with the machinery it controls. The user and any personnel involved with the installation and use of this product must be thoroughly familiar with all applicable standards, some of which are listed within the specifications. Banner Engineering Corp. makes no claim regarding a specific recommendation of any organization, the accuracy or effectiveness of any information provided, or the appropriateness of the provided information for a specific application.

Applicable U.S. Standards

ANSI B11 Standards for Machine Tools Safety

Contact: Safety Director, AMT – The Association for Manufacturing Technology, 7901 Jones Branch Drive, Suite 900, McLean, VA 22102-4206 USA, www.amtonline.org

NFPA 79 Electrical Standard for Industrial Machinery



Contact: National Fire Protection Association, 1 Batterymarch Park, Quincy, MA 02169-7471 USA, www.nfpa.org/

ANSI/RIA R15.06 Safety Requirements for Industrial Robots and Robot Systems

Contact: Robotic Industries Association, 900 Victors Way, Suite 140, Ann Arbor, MI 48108 USA, www.robotics.org

Applicable International Standards

EN ISO 12100 Safety of Machinery – Basic Concepts, General Principles for Design

EN 60204-1 Electrical Equipment of Machines Part 1: General Requirements

EN ISO 13849-1 Safety-Related Parts of Control Systems

ISO 13856-1 (EN1760-1), Safety of Machinery – Pressure-Sensitive Protective Devices

Contact: IHS Markit (Global Engineering Documents), 15 Inverness Way East, Englewood, CO 80112 USA, <https://global.ih.com/>

EU Declaration of Conformity (DoC)

Banner Engineering Corp. herewith declares that these products are in conformity with the provisions of the listed directives and all essential health and safety requirements have been met. For the complete DoC, please go to www.bannerengineering.com.

Product	Directive
STB Self-Checking Optical Touch Buttons	Machinery Directive 2006/42/EC

Representative in EU: Peter Mertens, Managing Director, Banner Engineering BV. Address: Park Lane, Culliganlaan 2F, bus 3,1831 Diegem, Belgium.

Overview

STB Self-Checking Optical Touch Buttons are touch-activated photoelectric devices designed to replace capacitive touch switches and mechanical push buttons. Their outputs activate while a finger is in the “touch area” (yoke) of the switch, interrupting the button’s infrared sensing beam.

Banner STB Series buttons are ergonomically designed to eliminate the hand, wrist, and arm stresses associated with mechanical push buttons. They require absolutely no physical pressure to operate. LED indicators light when power is on and outputs are activated.

All models are immune to EMI, RFI, and ambient light interference. STBs have a black polyetherimide upper housing and yellow PBT base. The 30 mm threaded base on all models provides easy mounting and easy retrofitting into existing applications. Rugged yellow polypropylene (TP) field covers are installed on all models to prevent inadvertent switch actuation due to objects (such as loose clothing or debris) which might accidentally block the sensing beam. The polypropylene material is capable of absorbing high impact (even at low temperatures) and is highly resistant to abrasion and to damage by most chemicals.

Figure 1. STB Touch Button features

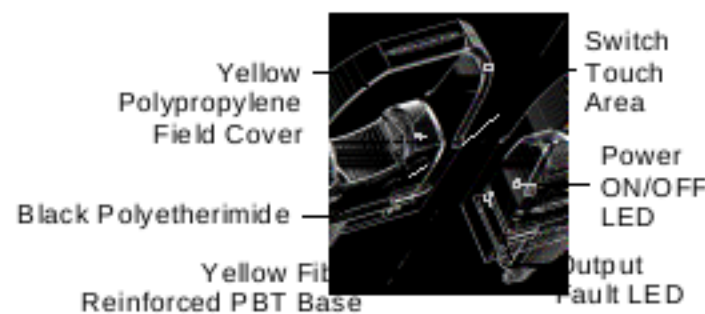

WARNING:

- Use adequate point-of-operation guarding
- Failure to properly guard hazardous machinery can result in a dangerous condition that could lead to serious injury or death.
- When properly installed, a two-hand control safety device provides protection only for the hands of the machine operator. It might be necessary to install additional safeguarding, such as safety light curtains, additional two-hand controls, and/or hard guards, to protect all individuals from hazardous machinery.

STB Self-Checking Optical Touch Buttons are very similar to the proven and popular OTB Series buttons. The dual-microcontroller internal design of the new buttons, however, allows the hookup to a Banner DUO-TOUCH SG Two-Hand-Control Safety Module, or other two-hand-control designed to meet Type IIIC requirements per ISO 13851 (EN 574) (requiring 1 normally open and 1 normally closed contact per input channel). These microcontrollers perform a continuous self-check. The emitter is continuously pulsed, and receiver response is checked accordingly by the microcontrollers. STB Series Touch Buttons are designed to immediately detect any internal component failure, go into a lockout mode, and indicate the failure with a flashing green Fault LED.

The STB outputs are not monitored by the STB circuitry, and have no external device monitoring feedback. Output monitoring must be accomplished by using an external device, such as a Type IIIC Two-Hand-Control module.

STB Series Touch Button LED Indicators	
Power On (green):	Solid when power is applied
Output, Fault (green):	Solid when button is activated
	Off when button is not activated
	Flashing when a fault condition is detected

STB Series Self-Checking Touch Buttons were designed primarily to provide the self-checking function required in control-reliable machine cycle initiation applications. STBs also are suitable for use anywhere mechanical push buttons or the original OTB Touch Buttons are used.

Both the solid-state and relay-output versions have complementary outputs and can be connected to switch power to equipment as long as the STB's switching voltage and current limits are not exceeded.

STBs must be connected to a type IIIC Two-Hand-Control circuit module, in most cases, when used to initiate potentially dangerous machine cycles.

Installation

OSHA and ANSI require that the hand controls be mounted to protect them from accidental or unintentional operation. Protective field covers are installed to prevent accidental switch actuation and to discourage use of forearms or elbows. European standard ISO 13851 (EN 574) includes a detailed discussion of approaches to protection of hand controls. The hand controls must be arranged far enough apart so that the operator cannot operate both hand controls by the use of one arm. Typically, this distance is not less than 550 mm (21.7 in) in a straight line, but using guards or alternate mounting arrangement can allow shorter distances, per ISO 13851 (EN574). This standard also recommends that hand controls be arranged on a horizontal (or nearly horizontal) surface that is 1,100 mm (43.3 in) above the floor.

Consider ergonomic principles to avoid unnecessary fatigue in the installation of the hand controls. Install the touch buttons at a height and in a location that will be comfortable for the user. See ISO 13851 (EN574) Two-Hand Control, ANSI B11.19.1 — Ergonomic Guidelines, and EN894— Safety of Machinery—Ergonomic Requirements—Control Actuators for further information.

Banner Engineering also manufactures runbars with STB buttons installed, see p/n 131634 for more information.

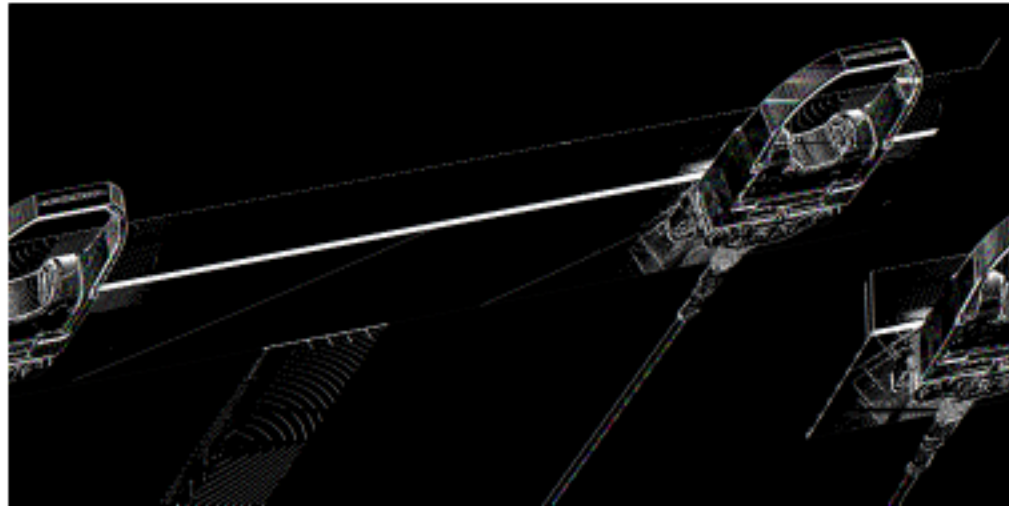

Figure 2. STB touch buttons mounted



CAUTION:

- Install hand controls to prevent accidental actuation
- It is not possible to completely protect the two-hand control system from defeat.
- OSHA regulations require the user to arrange and protect hand controls to minimize possibility of defeat or accidental actuation.



CAUTION:

- Avoid installing hand controls in contaminated environments—Severe contamination or other environmental influences could cause a slow response or false on condition of mechanical or ergonomic buttons.
- A slow response or false on condition could result in exposure to a hazard.
- The environment in which hand controls are installed must not adversely affect the means of actuation.

Two-Hand Control Safety Distance (Minimum Distance)

Both hand controls must be located far enough away from the nearest hazard point that the operator cannot reach the hazard with a hand or other body part before the hazardous motion ceases. This is the "separation distance" ("safety distance"), and may be calculated as follows.

**WARNING:**

- Mount hand controls at a safe distance from moving machine parts
- Failure to establish and maintain the safety distance (minimum distance) could result in serious injury or death.
- Mount hand controls as determined by the applicable standard. The operator or other non-qualified persons must not be able to relocate the hand controls.

U.S. Applications

The Safety Distance formula, as provided in ANSI B11.19:

Part-Revolution Clutch Machinery (the machine and its controls allow the machine to stop motion during the hazardous portion of the machine cycle)

$$D_s = K \times (T_s + T_r) + D_{pr}$$

For Full-Revolution Clutch Machinery (the machine and its controls are designed to complete a full machine cycle)

$$D_s = K \times (T_m + T_r + T_h)$$

D_s

the Safety Distance (in inches)

K

the OSHA/ANSI recommended hand-speed constant (in inches per second), in most cases is calculated at 63 in/s, but may vary between 63 in/s to 100 in/s based on the application circumstances;

not a conclusive determination; consider all factors, including the physical ability of the operator, when determining the value of K to be used.

T_h

the response time of the slowest hand control from the time when a hand disengages that control until the switch opens;

T_h is usually insignificant for purely mechanical switches. However, T_h should be considered for safety distance calculation when using electronic or electromechanical (powered) hand controls.

T_m

the maximum time (in seconds) the machine takes to cease all motion after it has been tripped. For full revolution clutch presses with only one engaging point, T_m is equal to the time necessary for one and one-half revolutions of the crankshaft. For full revolution clutch presses with more than one engaging point, T_m is calculated as follows:

$$T_m = (1/2 + 1/N) \times T_{cy}$$

N = number of clutch engaging points per revolution

T_{cy} = time (in seconds) necessary to complete one revolution of the crankshaft

T_r

the response time of the Safety Controller as measured from the time a stop signal from either hand control is received. The Safety Controller response time is obtained from the onfiguration Summary tab in the Software.

T_s

the overall stop time of the machine (in seconds) from the initial stop signal to the final ceasing of all motion, including stop times of all relevant control elements and measured at maximum machine velocity.

T_s is usually measured by a stop-time measuring device. If the specified machine stop time is used, add at least 20% as a safety factor to account for brake system deterioration. If the stop-time of the two redundant machine control elements is unequal, the slower of the two times must be used for calculating the separation distance.

European Applications

The Minimum Distance Formula, as provided in EN 13855:

$$S = (K \times T) + C$$

S

the Minimum Distance (in millimeters)

K

the EN 13855 recommended hand-speed constant (in millimeters per second), in most cases is calculated at 1600 mm/s, but may vary between 1600 mm/s to 2500 mm/s based on the application circumstances;

not a conclusive determination; consider all factors, including the physical ability of the operator, when determining the value of K to be used.

T

the overall machine stopping response time (in seconds), from the physical initiation of the safety device to the final ceasing of all motion.

C

the added distance due to the depth penetration factor equals 250 mm, per EN 13855. The EN 13855 C factor may be reduced to 0 if the risk of encroachment is eliminated, but the safety distance must always be 100 mm or greater.

Example Separation Distance Calculation

The following example illustrates the use of the formula to calculate separation distance for a part-revolution clutch machine. This example uses 0.50 seconds as a typical value for T_s and 0.035 seconds for T_r and 0.020 seconds for T_h :

$$\begin{aligned}
 K &= 63 \text{ in per second,} \\
 T_s &= 0.50 \text{ seconds (measured by a stop-time measuring device)} \\
 T_r &= 0.035 \text{ seconds} \\
 T_h &= 0.020 \text{ seconds} \\
 D_s &= K \times (T_s + T_r + T_h) \\
 &= 63 \text{ in } (0.50 + 0.035 + 0.020) \\
 &= 35 \text{ in}
 \end{aligned}$$

In this example, both hand controls must be located no closer than 35 in from the nearest hazard point.

Wiring Diagrams

Cabled models only are shown. Quick-disconnect wiring is functionally identical. Connection of DC power is without regard to polarity.

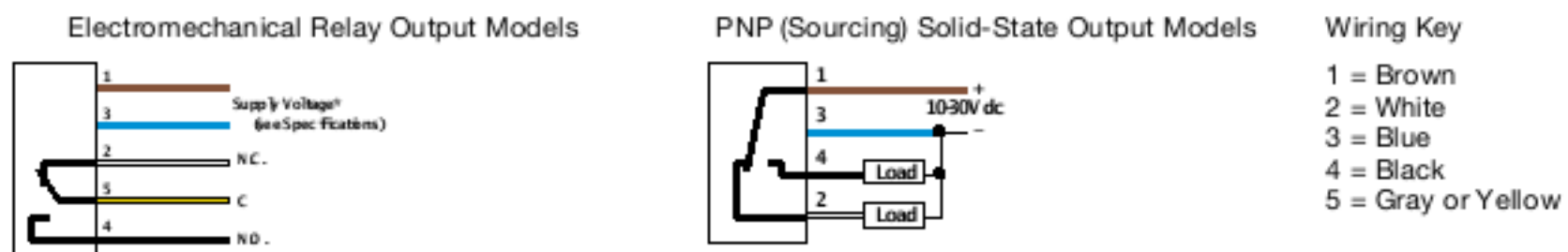

*NOTE: Connection of dc power is without regard to polarity.

Figure 3. Generic interface of a relay-output STB Touch Button to a type IIC two-hand-control module

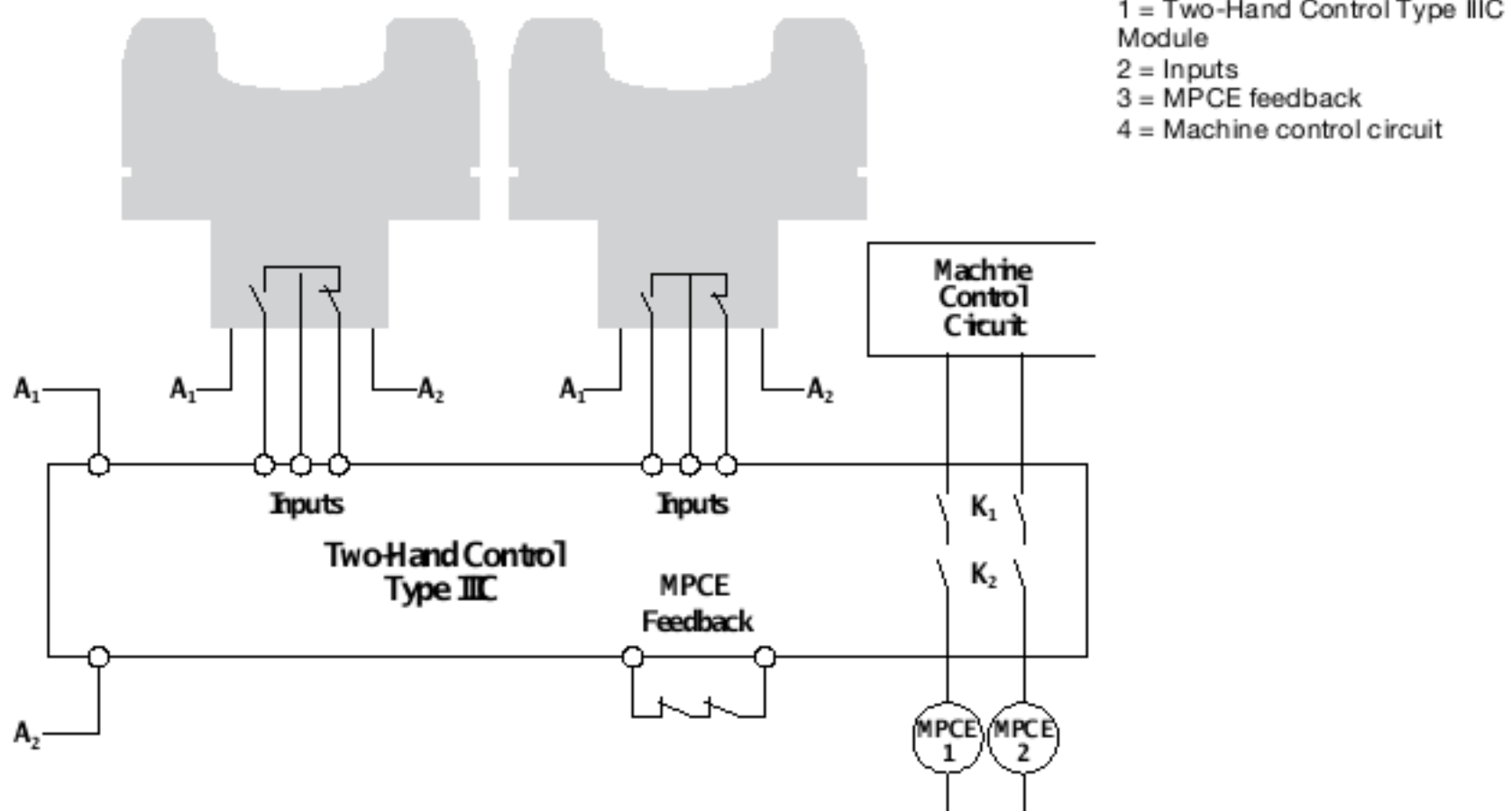

**WARNING:**

Safety Systems Used for Two-Hand-Control. In a two-hand-control/trip system that incorporates STB Touch Buttons as the actuation devices and functions as a safeguard, the anti-tiedown and simultaneity monitoring functions should not be performed by a nonsafety-related device (for example, a PLC or PC). Per OSHA 29CFR1910.211(d)(62), the "safety system must...operate together as a unit, such that a single failure or single operating error will not cause injury to personnel due to point-of-operation hazards."

Refer to the appropriate standard to determine the requirements of a two hand-control/trip system when used for safeguarding.

Figure 4. STB Touch Button block diagrams

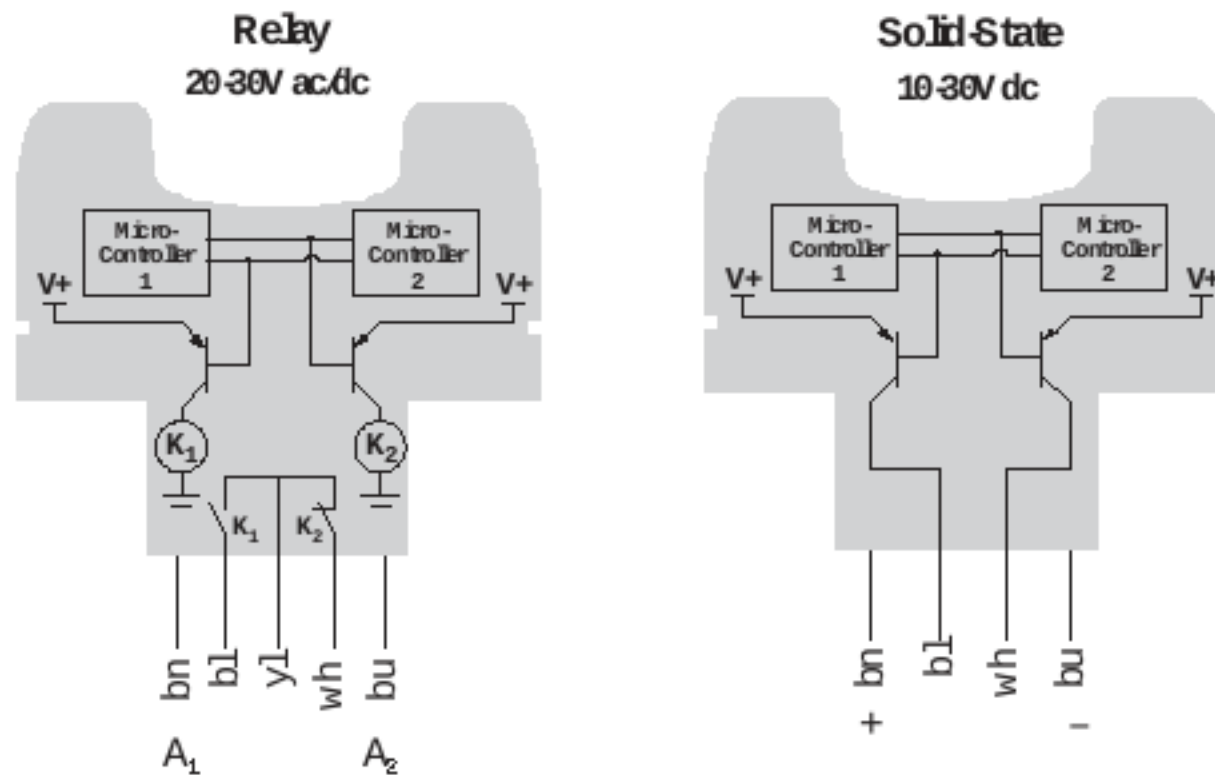

Repairs

Contact Banner Engineering for troubleshooting of this device. Do not attempt any repairs to this Banner device; it contains no field-replaceable parts or components. If the device, device part, or device component is determined to be defective by a Banner Applications Engineer, they will advise you of Banner's RMA (Return Merchandise Authorization) procedure.



Important: If instructed to return the device, pack it with care. Damage that occurs in return shipping is not covered by warranty.

ptions

Supply Voltage and Current

STBVP6 models: 10 V DC to 30 V DC at 75 mA, typical
 STBVR81 models: 20 V AC/DC to 30 V AC/DC or 20 V AC to 30 V AC (peak-to-peak value), (50/60 Hz \pm 5%) at 75 mA

Supply Protection Circuitry

Protected against reverse polarity and transient voltages

Output Configuration

STBVP6 models: Complementary PNP (sourcing) open-collector transistors
 STBVR81 models: Complementary electromechanical relays

Output Rating

STBVP6 models (solid-state outputs):

Max. load: 150 mA
 On-state max. output voltage (no load): +V(supply) – 1.5 V
 Off-state leakage current: < 1 μ A

STBVR81 models (electromechanical relays):

Max. switching voltage: 125 V DC/150 V AC
 Max. switching current: 1 A @at 24 V DC; 0.4 A at 125 V AC (resistive loads)
 Max. resistive power: 24 W DC/50 VA AC
 Mechanical life of relays: 10^9 cycles
 Electrical life of relays: 1.5×10^9 cycles at 1 amp, 24 V resistive

Output Protection Circuitry

All models protected against false pulse on power-up. Models with solid-state outputs have overload and short-circuit protection.

Output Response Time

20 milliseconds ON/OFF

Indicators

2 green LED indicators:

Power: ON – power applied
 Output/fault: ON – button is activated; OFF – button is deactivated;
 Flashing – internal fault or blocked button on power-up detected

Connections

PVC-jacketed 2 m (6.5 ft) cables or quick disconnect ~~trailing~~, depending on model; integral 9 m (30 ft) cables are also available. Accessory cables required for quick disconnect models.

STBVP6 models: 4-wire (4-pin Mini-style or Euro-style quick disconnect)
 STBVR81 models: 5-wire (5-pin Mini-style or Euro-style quick disconnect)

Environmental Rating

Meets NEMA 1, 3, 4, 4X, 12 and 13; IEC IP66

Construction

Totally encapsulated, non-metallic enclosure. Black polyetherimide upper housing; ~~flex-reinforced~~ PBT polyester base. Electronics fully epoxyencapsulated. Pre-installed polypropylene (TP) protective ~~held~~ cover.

Ambient Light Immunity

Up to 100,000 lux

Applicable Agency Standards

(Used with an AT-FM-10K module or an SC22-3 Safety Controller) Analysis of measures for fault avoidance and fault control according to SIL3 (IEC 61508 and IEC 62061) and Category 4 (EN ISO 13849-1) passes EMI/RFI test levels as ~~specified~~ in IEC61496 and IEC62061.

Operating Conditions

0 °C to +50 °C (+32 °F to +122 °F)
 90% at +50 °C maximum relative humidity (non-condensing)

Application Notes

The polyetherimide upper housing will become brittle with prolonged exposure to outdoor sunlight. Window glass effectively ~~filters~~ longer wavelength ultraviolet light and provides excellent protection from sunlight. Avoid contact with strong alkalis, hydrocarbons and fuels. Clean periodically using mild soap solution and a soft cloth.

Two-Hand Control System Note

When the STBVP6 is used with Banner's XS/SC26-2 or SC10-2 Safety Controllers in a two-hand control system, the power supply to the STBVP6 must be of the same voltage that is used to power the Safety Controller and they must have a common supply ground.

certifications



Dimensions

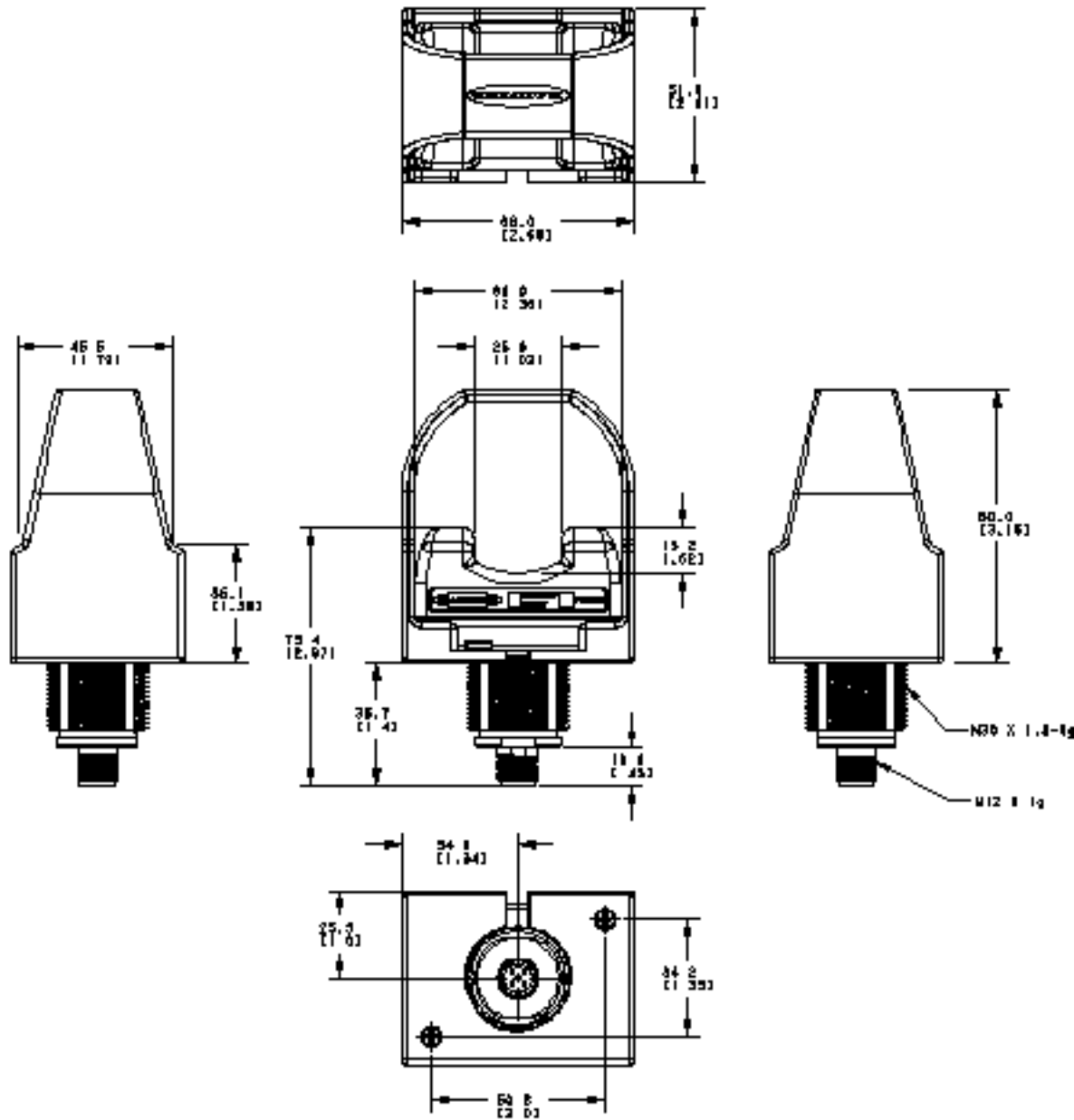





Accessories

Cordsets

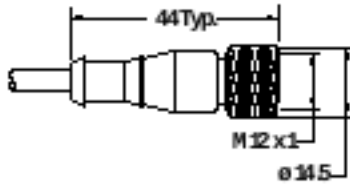
4-Pin Mini-Style Cordsets – Single Ended				
Model	Length	Style	Dimensions	Pinout (Female)
MBCC-406	1.83 m (6 ft)	Straight		<p>1 = Brown 2 = White 3 = Blue 4 = Black</p>
MBCC-412	3.66 m (12 ft)			
MBCC-430	9.14 m (30 ft)			

5-Pin Mini-Style Cordsets – Single Ended				
Model	Length	Style	Dimensions	Pinout (Female)
MBCC-506	1.83 m (6 ft)	Straight		<p>1 = Black 2 = Blue 3 = Yellow 4 = Brown 5 = White</p>
MBCC-512	3.66 m (12 ft)			
MBCC-530	9.14 m (30 ft)			

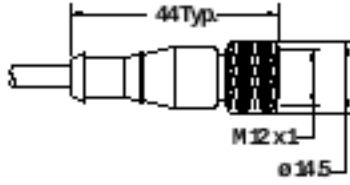
4-Pin Threaded M12/Euro-Style Cordsets—Single Ended				
Model	Length	Style	Dimensions	Pinout (Female)
MQDC-406	1.83 m (6 ft)	Straight		 <p>1 = Brown 2 = White 3 = Blue 4 = Black</p>
MQDC-415	4.57 m (15 ft)			
MQDC-430	9.14 m (30 ft)			
MQDC-450	15.2 m (50 ft)			

5-Pin Threaded M12/Euro-Style Cordsets—Single Ended				
Model	Length	Style	Dimensions	Pinout (Female)
MQDC1-501.5	0.5 m (1.5 ft)	Straight		 <p>1 = Brown 2 = White 3 = Blue 4 = Black 5 = Gray</p>
MQDC1-506	2 m (6.5 ft)			
MQDC1-515	5 m (16.4 ft)			
MQDC1-530	9 m (29.5 ft)			

Mounting Brackets

SMB30MM

- 12-ga. stainless steel bracket with curved mounting slots for versatile orientation
- Clearance for M6 (¼ in) hardware
- Mounting hole for 30 mm sensor

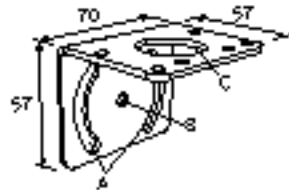

Hole center spacing: A = 51, A to B = 25.4
Hole size: A = 42.6 x 7, B = ø 6.4, C = ø 30.1

SMB30SC

- Swivel bracket with 30 mm mounting hole for sensor
- Black reinforced thermoplastic polyester
- Stainless steel mounting and swivel locking hardware included

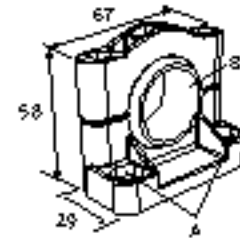

Hole center spacing: A=ø 50.8
Hole size: A=ø 7.0, B=ø 30.0

SMBAMS30P

- Flat SMBAMS series bracket
- 30 mm hole for mounting sensors
- Articulation slots for 90°+ rotation
- 12-ga. 300 series stainless steel

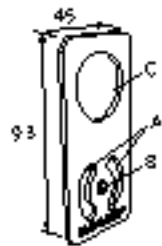

Hole center spacing: A=26.0, A to B=13.0
Hole size: A=26.8 x 7.0, B=ø 6.5, C=ø 31.0

SMBAMS30RA

- Right-angle SMBAMS series bracket
- 30 mm hole for mounting sensors
- Articulation slots for 90°+ rotation
- 12-ga. (2.6 mm) cold-rolled steel

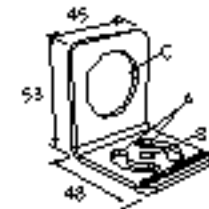

Hole center spacing: A=26.0, A to B=13.0
Hole size: A=26.8 x 7.0, B=ø 6.5, C=ø 31.0

SMB30A

- Right-angle bracket with curved slot for versatile orientation
- Clearance for M6 (¼ in) hardware
- Mounting hole for 30 mm sensor
- 12-ga. stainless steel

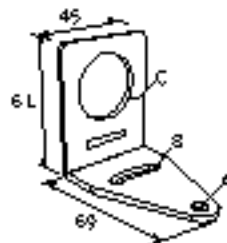

Hole center spacing: A to B=40
Hole size: A=ø 6.3, B= 27.1 x 6.3, C=ø 30.5

Banner Engineering Corp Limited Warranty

Banner Engineering Corp. warrants its products to be free from defects in material and workmanship for one year following the date of shipment. Banner Engineering Corp. will repair or replace, free of charge, any product of its manufacture which, at the time it is returned to the factory, is found to have been defective during the warranty period. This warranty does not cover damage or liability for misuse, abuse, or the improper application or installation of the Banner product.

THIS LIMITED WARRANTY IS EXCLUSIVE AND IN LIEU OF ALL OTHER WARRANTIES WHETHER EXPRESS OR IMPLIED (INCLUDING, WITHOUT LIMITATION, ANY WARRANTY OF MERCHANTABILITY OR FITNESS FOR A PARTICULAR PURPOSE), AND WHETHER ARISING UNDER COURSE OF PERFORMANCE, COURSE OF DEALING OR TRADE USAGE.

This Warranty is exclusive and limited to repair or, at the discretion of Banner Engineering Corp., replacement. IN NO EVENT SHALL BANNER ENGINEERING CORP. BE LIABLE TO BUYER OR ANY OTHER PERSON OR ENTITY FOR ANY EXTRA COSTS, EXPENSES, LOSSES, LOSS OF PROFITS, OR ANY INCIDENTAL, CONSEQUENTIAL OR SPECIAL DAMAGES RESULTING FROM ANY PRODUCT DEFECT OR FROM THE USE OR INABILITY TO USE THE PRODUCT, WHETHER ARISING IN CONTRACT OR WARRANTY, STATUTE, TORT, STRICT LIABILITY, NEGLIGENCE, OR OTHERWISE.

Banner Engineering Corp. reserves the right to change, modify or improve the design of the product without assuming any obligations or liabilities relating to any product previously manufactured by Banner Engineering Corp. Any misuse, abuse, or improper application or installation of this product or use of the product for personal protection applications when the product is identified as not intended for such purposes will void the product warranty. Any modifications to this product without prior express approval by Banner Engineering Corp will void the product warranties. All specifications published in this document are subject to change; Banner reserves the right to modify product specifications or update documentation at any time. Specifications and product information in English supersede that which is provided in any other language. For the most recent version of any documentation, refer to: www.bannerengineering.com.

For patent information, see www.bannerengineering.com/patents.