

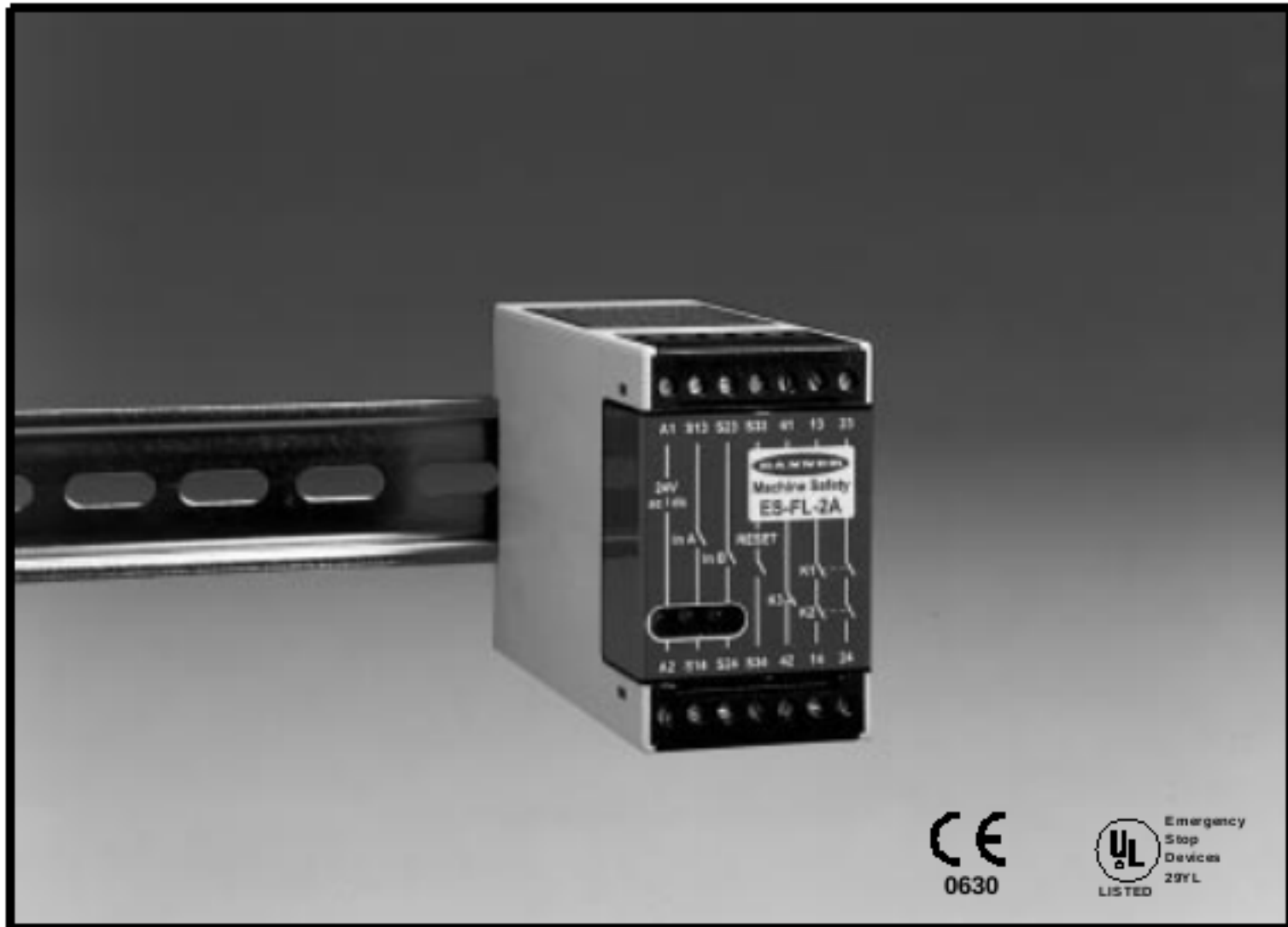

Emergency Stop Monitoring Safety Relay

Model ES-FL-2A



- Monitors two normally-closed emergency stop switch circuits for a contact failure or wiring fault
- Input monitoring circuit uses a diverse-redundant design
- Requires a reset routine for controlled re-application of power to the machinery as per ANSI standard B11.20-1991
- Two output switching channels for connection to control-reliable power interrupt circuits
- Auxiliary non-safety contact for status monitoring by process controller
- Design complies with standards UL991, EN418, and EN954-1(Safety Category 4)
- UL approved as Category NISD Emergency Stop Device
- For use in functional stop category 0 applications per NFPA 79 and EN418



46262

IMPORTANT NOTICE

Banner Engineering Corp. has made every effort to provide complete application, installation, operation, and maintenance instructions. In addition, any questions regarding the use or installation of Banner Emergency Stop Monitoring Safety Relay model **ES-FL-2A** should be directed to the factory applications department at the telephone numbers or address shown on back cover.

The user shall ensure that all machine operators, maintenance personnel, electricians, and supervisors are thoroughly familiar with and understand all instructions regarding the installation, maintenance, and use of model **ES-FL-2A** Emergency Stop Monitoring Safety Relay, and with the machinery it controls.

The user and any personnel involved with the installation and use of model **ES-FL-2A** Emergency Stop Monitoring Safety Relay must be thoroughly familiar with all applicable ANSI/NFPA standards. The standards, listed below, directly address the use of emergency stop systems. Banner Engineering Corp. makes no claim regarding a specific recommendation of any organization, the accuracy or effectiveness of any information provided, or the appropriateness of the provided information for a specific application.

The user has the responsibility to ensure that all local, state, and national laws, rules, codes, and regulations relating to the use of this emergency stop monitoring safety relay in any particular application are satisfied. Extreme care is urged that all legal requirements have been met and that all installation and maintenance instructions contained in this manual are followed.

U. S. Standards Applicable to Use of Emergency Stop Monitoring Safety Relays

ANSI B11 Standards	"Standards for Construction, Care, and Use of Machine Tools"
NFPA 79	"Electrical Standard for Industrial Machinery 1994 Edition"
Available from:	Safety Director National Machine Tool Builders Association 7901 West park Drive McLean, VA 22102-4269

European Standards Applicable to Use of Emergency Stop Monitoring Safety Relays

EN292-1	"Safety of Machinery - Basic Concepts, General Principals for Design Part 1: Basic Terminology, Methodology"
EN292-2	"Safety of Machinery - Basic Concepts, General Principals for Design Part 2: Technical Principals and Specifications"
EN60204-1	"Electrical Equipment of Machines: Part 1: General Requirements"
Available from:	Global Engineering Documents 15 Inverness Way East Englewood, CO 80112-5704

Also, request a type "C" standard for your specific machinery.



WARNING Model **ES-FL-2A** Emergency Stop Monitoring Safety Relay is not a point of operation guarding device, as defined by OSHA regulations. It is necessary to install point of operation guarding devices, such as safety light curtains and/or hard guards, to protect personnel from hazardous machinery. Failure to install point of operation guards on hazardous machinery can result in a dangerous condition which could lead to serious injury or death.

SECTION 1 – Product Description

The purpose of safety relay model ES-FL-2A is to increase the control reliability of an emergency stop circuit. The ANSI B11.19 standard states:

“Control reliability of electrical, electronic, or pneumatic systems frequently consists of multiple, independent parallel or series circuitry or components so arranged that any single failure would not significantly affect the stopping performance of the system or the machine tool. **If a failure of a component has occurred, this arrangement either sends a stop command to the machine tool or prevents a successive cycle from being initiated.**”

As indicated in Figure 2 or 3, a typical emergency stop switch offers two redundant switching contacts. In a properly-designed machine stop circuit, the opening of either of the two emergency stop contacts immediately removes electrical power from the machine control elements which react to stop hazardous machine motion and/or any other machine hazard. This redundancy of stopping control offered by a two-pole emergency stop switch is the first step towards control reliability. However, failure or defeat of one of the switch contacts to a short-circuit will go undetected, thereby removing the redundancy, and leaving the emergency stop circuit prone to eventual failure.

The ES-FL-2A safety relay connects between the emergency stop switch and the machine emergency stop control elements. The emergency stop switch becomes an input to the safety relay. The safety relay monitors the condition of both contacts of the emergency stop switch. The output of the safety relay consists of two redundant output switching channels, each of which is the series connection of two safety relay contacts (K1 and K2 in Figure 2). The Control Reliability section of ANSI B11.19 goes on to state:

“Electromechanical systems that require redundancy and checking of relay contacts should use relays that are designed with mechanical linkages to provide relation between normally open and normally closed contacts to check the contact operation.”

Safety relays K1 and K2 in the output circuit of the ES-FL-2A safety relay have mechanically-linked contacts which allow the safety relay circuitry to monitor the contacts of K1 and K2 for failure. If the safety relay detects failure of any contact of either the input emergency stop switch or the output relays, the safety relay output is disabled and cannot be reset.

The ES-FL-2A safety relay also provides a necessary reset function. ANSI B11 and NFPA 79 standards require that a reset routine be performed after returning the emergency stop switch to its closed-contact position. This prevents the controlled machinery from restarting by simply closing the emergency stop switch.

The two switching output circuits of the safety relay are rated for up to 250V ac at up to 4 amps (resistive load). A low-capacity non-safety auxiliary contact (between terminals #41 and 42) provides a monitoring signal for a process controller.

The ES-FL-2A emergency stop monitoring safety relay complies with the following design standards:

- UL991 Tests for Safety Related Control Employing Solid-state Devices
- EN418 Emergency Stop Equipment - Functional Aspects, Principals for Design
- EN954-1 Safety of Machines: Safety-related Parts of Controllers Part 1: General Design Directives (Safety Category 4)

The safety relay has indicators for input power and output relay contact status (see Figure 1). There are no adjustments and no user-serviceable parts. See page 7 for information regarding repair service.

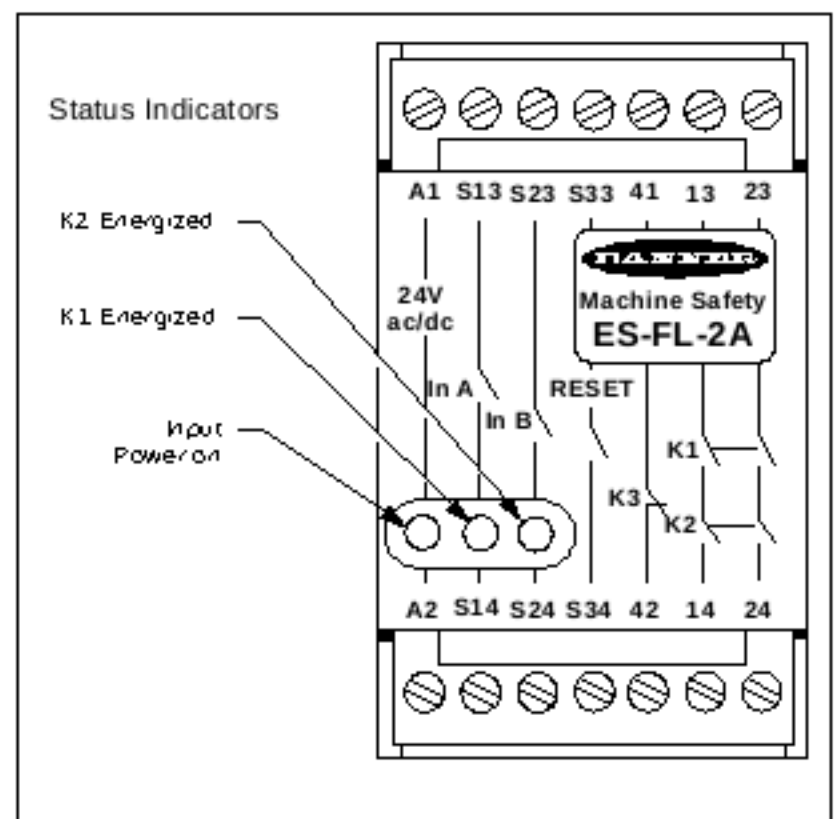

Figure 1. ES-FL-2A Status Indicators

E-Stop Safety Relay

SECTION 2 – Emergency Stop Switch Requirements

As shown in Figure 2 or 3, the emergency stop switch must provide two contacts which are closed when the switch is in the “armed” position. Once activated, the emergency stop switch must open both contacts. The switch may be returned to the closed-contact position only by a deliberate action such as twisting, pulling, unlocking, etc. Additionally, ANSI B11 standards specify the following switch (i. e. “stop control”) requirements:

“A typical stop control may be a button, cable, trip bar, foot control, or other sensing means. The stop control should be colored red and should be clearly labeled.”

“An emergency stop control shall be provided for each operator control station or position and shall be readily distinguishable from all other operating controls.”

SECTION 3 – Mechanical Installation

The model ES-FL-2A safety relay must be installed inside an enclosure. It is not designed for exposed wiring. It is the user's responsibility to house the safety relay in an enclosure with NEMA 3 (IEC IP54) rating, or better.

Dimensions of the safety relay are shown in the diagram on page 8. The safety relay mounts directly to standard 35mm DIN rail.

SECTION 4 – Electrical Installation

It is not possible to give exact wiring instructions for a device such as the model ES-FL-2A emergency stop monitoring safety relay which interfaces to a multitude of machine control configurations. The following guidelines are general in nature.

Model ES-FL-2A has no delay function. The output relay contacts open (and the monitoring contact closes) within 25 milliseconds from the time that either emergency stop switch contact opens. This classifies the ES-FL-2A as a functional “Category 0” emergency stop control as defined by NFPA 79 (National Fire Protection Association Standard for Industrial Machinery) and EN418 (European Standard: “Safety of Machinery, Emergency Stop Equipment, Functional Aspects – Principles of Design”).



CAUTION Always disconnect power from the ES-FL-2A safety relay and **all** power from the machine being controlled before making any wire connections.

Electrical installation and wiring must be made by qualified personnel and must comply with the NEC (National Electrical Code), EN60204-1 and -2, and all applicable local standards and codes.

SECTION 4.1 – Connection of Emergency Stop Switch

Connect the two poles of the emergency stop switch as shown in Figure 2. The switch in Figure 2 is shown in its “armed” position with both contacts closed. Multiple emergency stop switches connected to one safety relay must use a series connection (see Figure 3 and the warning, below).



WARNING Whenever two or more emergency stop switches are connected to the same ES-FL-2A safety relay, contacts of the corresponding pole of each switch must be connected together in series. This series combination is then wired to the respective safety relay input (i.e. to either S13 and S14 or S23 and S24). **Never connect the contacts of multiple emergency stop switches in parallel to the ES-FL-2A safety relay inputs.** Parallel connection of two or more emergency stop switches to one ES-FL-2A safety relay defeats the switch contact monitoring ability of the safety relay, and creates an unsafe condition which could result in serious injury or death.

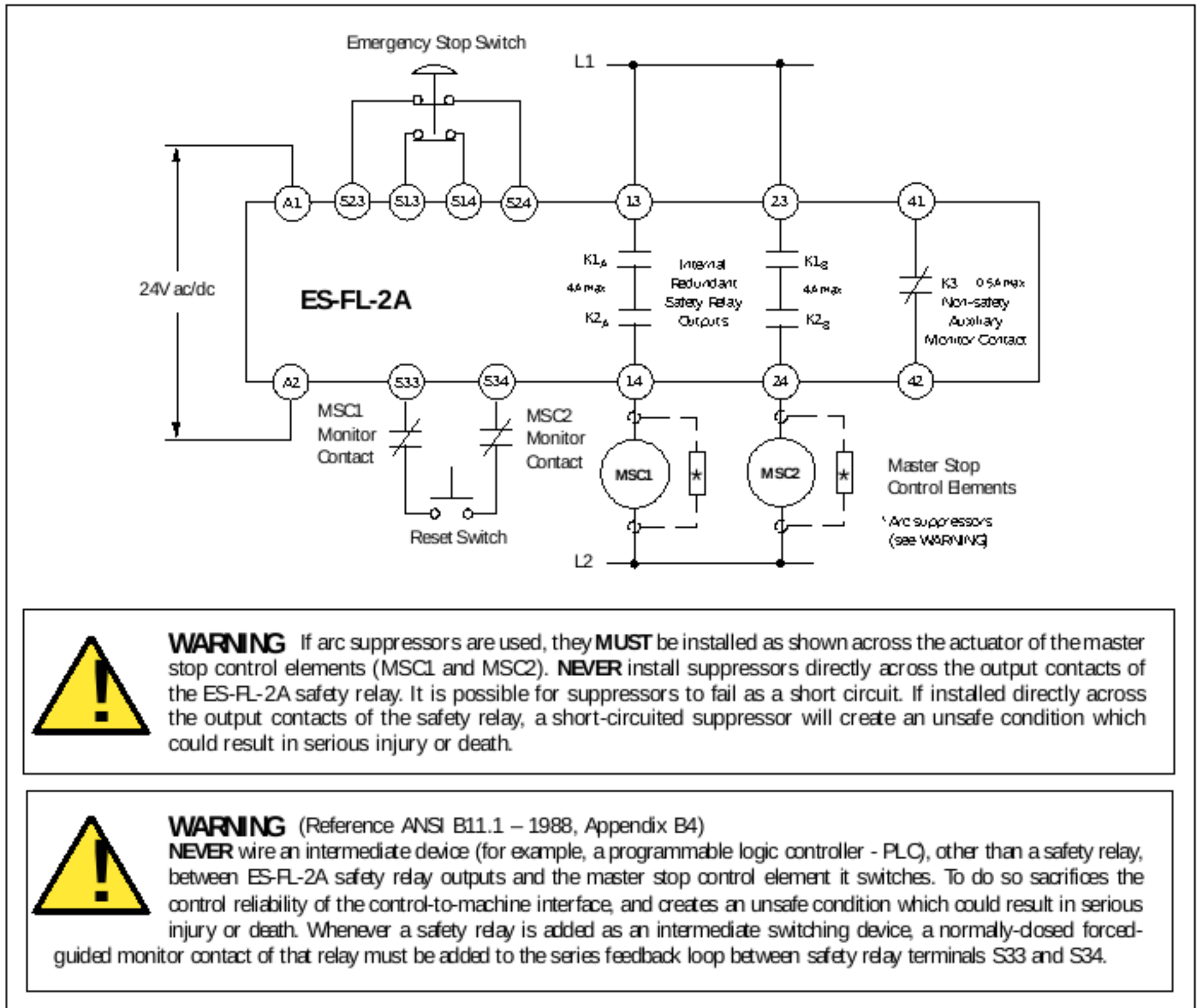

Figure 2. Hookup of ES-FL-2A Emergency Stop Monitoring Safety Relay

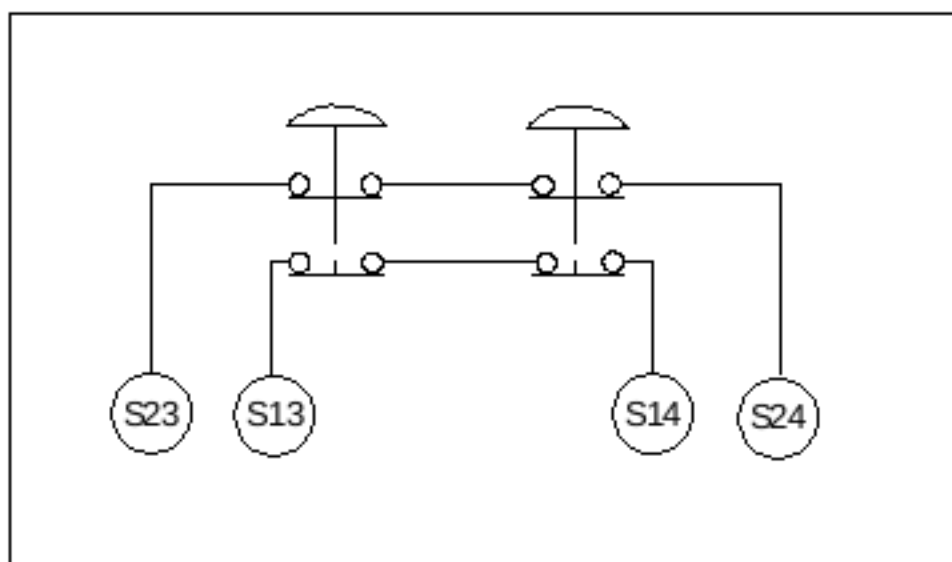

Figure 3. Series Connection of Multiple Emergency Stop Switches

IMPORTANT Check ALL emergency stop switches, individually, during each checkout procedure.

E-Stop Safety Relay

SECTION 4.2 – Connection to the Machine to be Controlled

The hookup diagram (Figure 2) shows a generic connection of the ES-FL-2A safety relay's two redundant output circuits to master stop control elements MSC1 and MSC2. A master stop control element is defined as an electrically-powered device, external to the ES-FL-2A safety relay, which stops the machinery being controlled by immediate removal of electrical power to the machine and (when necessary) by applying braking to dangerous motion (reference ANSI B11.19, section 5.2: "Stop Control"). This stopping action is accomplished by removing power to the actuator of either master stop control element.

To satisfy the requirements of Safety Category 4 of prEN 954-1, the master stop control elements must be safety relays which offer a normally-closed forced-guided monitor contact. One normally-closed monitor contact from each master stop control element is wired in a series connection together with the normally-open RESET switch (see Figure 2). In operation, if one of the switching contacts of either master stop control element fails in the shorted condition, the associated monitor contact will remain open. Therefore, it will not be possible to reset the ES-FL-2A safety relay.

SECTION 4.3 – Connection of Reset Switch

The reset circuit switch can be any mechanical switch such as a normally-open momentary switch, a two-position key switch, etc. The reset switch must be capable of reliably switching 12 to 18V dc at 40 to 100 milliamps. As shown in Figure 2, and discussed, above, **the reset switch must be wired in series with a normally-closed monitor contact of each of the two master stop control elements.** This series circuit connects between terminals S33 and S34 of the safety relay.

The reset switch must be located outside of the area of dangerous motion, and must be positioned so that any area of dangerous motion may be observed by the switch operator during the reset operation.

IMPORTANT NOTE: Any access to dangerous machine motion must be guarded using safety interlocks and/or point-of-operation presence sensing devices which prevent hazardous machine motion when interrupted. Presence sensing devices, such as safety mats, must be used in any space between machine guards and any danger point which is large enough to allow a person to stand undetected by presence sensing devices.

SECTION 4.4 – Connection to the Auxiliary Monitor Contact

The action of the auxiliary monitor contact, K3, inversely "follows" the action of the output relays, K1 and K2 when power is applied to the ES-FL-2A safety relay. The contact of K3 is open when the output contacts of K1 and K2 are closed, and vice versa. The K3 auxiliary monitor contact is a light-duty contact to be used **only for control functions that are NOT safety-related.** A typical use is to communicate the status of the safety relay output to a programmable logic controller (PLC). The switching capacity of the K3 auxiliary monitor contact is 125V ac or V dc maximum at 500 mA maximum (resistive load). Connection to the auxiliary monitor contact is made at terminals 41 and 42 (see Figure 2).



CAUTION Before performing the initial checkout procedure, make certain all power is disconnected from the machine to be controlled. Dangerous voltages may be present along the ES-FL-2A wiring barriers whenever power to the machine control elements is "on". **Exercise extreme caution whenever machine control power is or may be present. Always disconnect power to the machine control elements before opening the enclosure housing the ES-FL-2A.**

SECTION 5 – Initial Checkout Procedure

Checkout procedure:

- 1) Remove power from the machine control elements.
- 2) Activate the emergency stop switch (open its contacts).

- 3) Apply input power (only) to the ES-FL-2A safety relay at terminals A1 and A2. Verify that only the **Input Power** indicator (Figure 1) is on. If either of the other two indicators is on at this point, disconnect the input power and check all wiring. Return to step 2 after the cause of the problem has been corrected.
- 4) Arm the emergency stop switch (close its contacts). Close the reset switch. The **K1** and **K2** indicators should remain off. Open the reset switch. The **K1** and **K2** indicators should both come on at this time. If either indicator comes on before the reset switch is opened, disconnect the input power and check all wiring. Return to step 2 after the cause of the problem has been corrected.
- 5) Activate the emergency stop switch (open its contacts). The **K1** and **K2** indicators should turn off, simultaneously. If either indicator does not go off, disconnect the input power and check all wiring. Return to step 2 after the cause of the problem has been corrected.
- 6) Close the enclosure. Apply power to the machine control elements and perform the Periodic Checkout Procedure (see following information).

IMPORTANT NOTE If more than one emergency stop switch is series-connected to one ES-FL-2A safety relay, the above checkout procedure must be run individually for **EACH** switch.

SECTION 6 – Periodic Checkout Procedure

We recommend that the emergency stop system be checked at each shift change or machine setup change.

- 1) With the machine running, engage the emergency stop switch (open its contacts). Verify that the machine stops.
- 2) Return the emergency stop switch to its closed-contact position. Close and then open the reset switch. Verify that the machine restarts.

IMPORTANT NOTE If two or more emergency stop switches are series-connected to one ES-FL-2A safety relay, this test must be individually run for **EACH** switch.

SECTION 7 – Repairs

NOTE: Do not attempt any repairs to the ES-FL-2A Emergency Stop Monitoring Safety Relay. It contains no field-replaceable components. Return the safety relay to the factory for warranty repair or replacement:

**Banner Engineering Corp.
Repair Department
715 North County Rd. 19
Aberdeen, SD 57401**

Banner Engineering Corp Limited Warranty



Banner Engineering Corp. warrants its products to be free from defects in material and workmanship for one year following the date of shipment. Banner Engineering Corp. will repair or replace, free of charge, any product of its manufacture which, at the time it is returned to the factory, is found to have been defective during the warranty period. This warranty does not cover damage or liability for misuse, abuse, or the improper application or installation of the Banner product.

THIS LIMITED WARRANTY IS EXCLUSIVE AND IN LIEU OF ALL OTHER WARRANTIES WHETHER EXPRESS OR IMPLIED (INCLUDING, WITHOUT LIMITATION, ANY WARRANTY OF MERCHANTABILITY OR FITNESS FOR A PARTICULAR PURPOSE), AND WHETHER ARISING UNDER COURSE OF PERFORMANCE, COURSE OF DEALING OR TRADE USAGE.

This Warranty is exclusive and limited to repair or, at the discretion of Banner Engineering Corp., replacement. **IN NO EVENT SHALL BANNER ENGINEERING CORP. BE LIABLE TO BUYER OR ANY OTHER PERSON OR ENTITY FOR ANY EXTRA COSTS, EXPENSES, LOSSES, LOSS OF PROFITS, OR ANY INCIDENTAL, CONSEQUENTIAL OR SPECIAL DAMAGES RESULTING FROM ANY PRODUCT DEFECT OR FROM THE USE OR INABILITY TO USE THE PRODUCT, WHETHER ARISING IN CONTRACT OR WARRANTY, STATUTE, TORT, STRICT LIABILITY, NEGLIGENCE, OR OTHERWISE.**

Banner Engineering Corp. reserves the right to change, modify or improve the design of the product without assuming any obligations or liabilities relating to any product previously manufactured by Banner Engineering Corp.

E-Stop Safety Relay

Product Specifications	
Supply Voltage and Current	24V ac/dc $\pm 15\%$ at 250mA maximum; 10% maximum ripple for dc operation
Supply Protection Circuitry	Protected against transient voltages and reverse polarity (dc hookup is without regard to polarity)
Output Configuration	<p>Outputs (K1 and K2): two redundant (i. e. total of four) safety relay (forced-guided) contacts</p> <p>Contact ratings: Maximum voltage: 250V ac or 250V dc Maximum current: 4A ac or dc (resistive load) Maximum power: 1000VA, 20 watts Mechanical life: 10,000,000 operations Electrical life: 100,000 at full resistive load</p> <p>NOTE: Transient suppression is recommended when switching inductive loads. Install suppressors across load. Never install suppressors across output contacts (see Warning on page 5).</p> <p>Auxiliary Monitor Output (K3): One non-safety relay contact Maximum switching voltage: 125V ac or V dc Maximum switching current: 500 mA (resistive load)</p>
Output Response Time	25 milliseconds maximum
Input Requirements	Emergency stop switch must have two normally closed contacts each capable of switching 40 to 100mA @ 12 to 18V dc. Reset switch must have one normally open contact capable of switching 40 to 100mA @ 12 to 18V dc.
Status Indicators	3 green LED indicators: Power ON K1 energized K2 energized
Housing	Polycarbonate. Rated NEMA 1 (IECIP20)
Mounting	Mounts to standard 35 mm DIN rail track. Relay safety relay must be installed inside an enclosure rated NEMA 3 (IECIP54), or better.
Vibration Resistance	10 to 55Hz @ .35mm displacement per IEC 68-2-6
Operating Temperature	0 to 50°C (32 to 122°F)
Dimensions	See diagram, below
Certifications	 

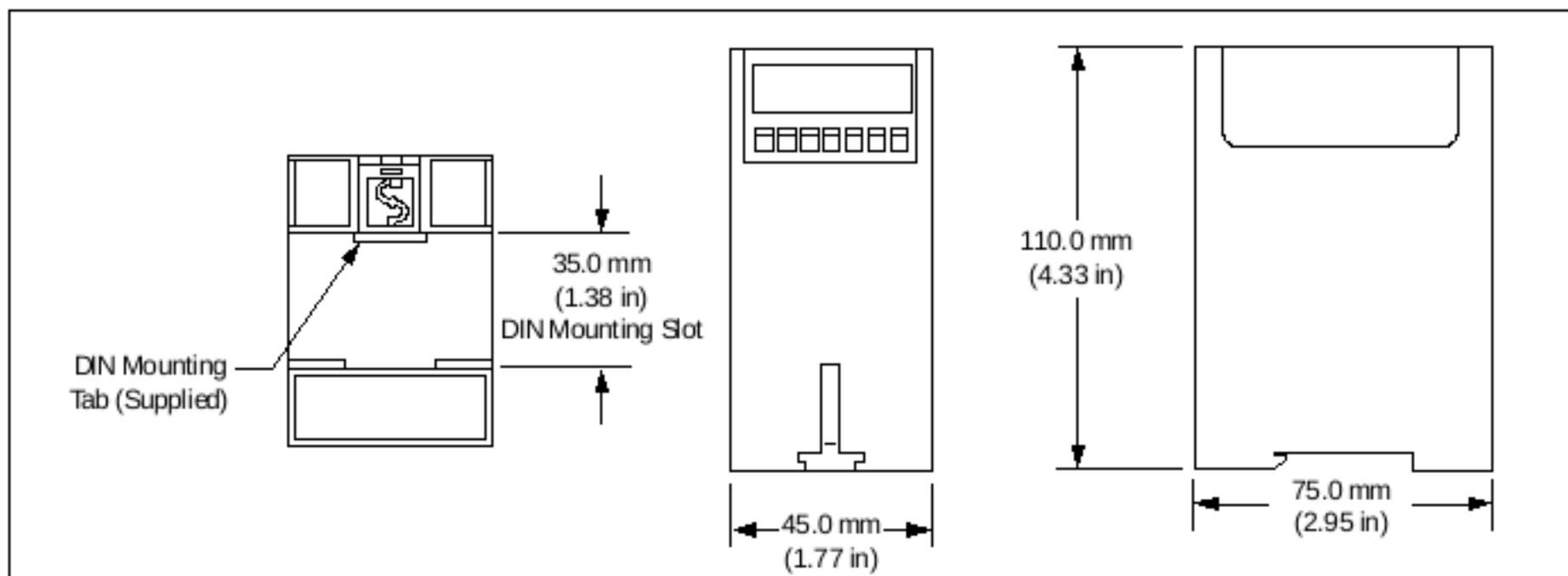

Figure 4. E-Stop Enclosure Dimensions