

B25 Wide Beam Retroreflective Sensor Product Manual



Original Instructions

p/n: 243320 Rev. A

27-Feb-25

© Banner Engineering Corp. All rights reserved. www.bannerengineering.com

Contents

- Chapter 1 Product Description.....3**
 - 1.1 Models.....3
 - 1.2 Product Overview.....3
 - 1.3 Features and Indicators.....4

- Chapter 2 Installation Instructions.....5**
 - 2.1 Mount the Device.....5
 - 2.2 Wiring.....5

- Chapter 3 Configuration Instructions.....6**
 - 3.1 TEACH Button Overview.....6
 - 3.2 Remote Input.....7
 - 3.3 TEACH Procedures.....7
 - 3.3.1 Static TEACH.....8
 - 3.3.2 Dynamic TEACH.....8
 - 3.3.3 Adjust the Sensitivity.....9
 - 3.3.4 Set Light Operate (LO) or Dark Operate (DO).....10
 - 3.3.5 Set a Delay.....11
 - 3.3.6 Input/Output Configuration for Channel 2.....12
 - 3.3.7 Enable or Disable the Drift Filter.....13
 - 3.4 Reset the Sensor to Factory Default Settings.....14
 - 3.4.1 Factory Default Settings.....14

- Chapter 4 IO-Link Interface.....15**

- Chapter 5 Specifications.....16**
 - 5.1 Dimensions.....17

- Chapter 6 Accessories.....18**
 - 6.1 Cordsets.....18
 - 6.2 Brackets.....19
 - 6.3 Reflectors.....19

- Chapter 7 Product Support.....20**
 - 7.1 Supporting Documentation.....20
 - 7.2 Troubleshooting.....20
 - 7.3 Clean Sensor with Compressed Air and Lint-Free Cloth.....20
 - 7.4 Repairs.....20
 - 7.5 Contact Us.....21
 - 7.6 Banner Engineering Corp Limited Warranty.....21

Chapter Contents

1.1 Models.....3
 1.2 Product Overview.....3
 1.3 Features and Indicators.....4

Chapter 1 Product Description



- Superior detection across a wide beam regardless of target shape, position, or material
 - * Reliably detects targets as small as 3 mm, such as mailers or polybags
 - * Detects the leading edges of packages anywhere within the 25 mm beam
 - * Avoids chatter caused by targets with folded edges, holes, or open flaps that would be an issue for other sensors
 - * Effectively detects challenging targets including dark, shiny, and clear
- Intuitive, user-friendly design simplifies installation, commissioning, and maintenance
 - * Quick set up and configuration with a single button, remote input wire, or IO-Link interface
 - * Intelligently learns belt characteristics and optimizes sensing to ignore belt flutter and seams
 - * Optimize variable sensitivity settings for clear targets or dirty environments
 - * Efficiently route cables with a multi-channel cable exit

WARNING:



- Do not use this device for personnel protection
- Using this device for personnel protection could result in serious injury or death.
- This device does not include the self-checking redundant circuitry necessary to allow its use in personnel safety applications. A device failure or malfunction can cause either an energized (on) or de-energized (off) output condition.

1.1 Models

Models	Detection Range	Supply Voltage	Output	Connection
B25-K6LP-Q5	0 m to 2 m (0 ft to 6.6 ft) ⁽¹⁾	10 V DC to 30 V DC	Push-Pull with IO-Link, PNP	100 mm (6 in) PVC-jacketed cable with a 4-pin M12 quick-disconnect connector

1.2 Product Overview

The B25 is an industrial retroreflective sensor that utilizes a 25 mm wide beam to reliably detect targets.

The wide beam is capable of detecting targets as small as 3 mm anywhere within the 25 mm beam. This is vital for leading edge applications which include targets that may have an inconsistent edge, such as mailers or polybags. Targets with folded edges, holes, or open flaps are consistently detected when other sensors would chatter with these types of targets. Configure the sensor with a simple push button and the LED indicators on the back of the housing, with a remote input wire, or with IO-

⁽¹⁾ Range with a BRT-S1XS1BM reflector.

Link. The multi-channel cable routing on the bottom cleanly routes the cable away from the sensor, regardless of how the sensor is mounted.

Use ["Configuration Instructions" on page 6](#) to set up the sensor. A sensor is in standard sensitivity by default, and the output switches when the LED next to the "Stnd" marking on the sensor turns off.

1.3 Features and Indicators

Figure 1. Features



The bar graph represents several functions. During Run mode, it shows how much light is being blocked. During sensor configuration, it shows the current setup or options, depending on the step being performed.

In Run mode, press the TEACH button one time to view the current sensor settings. For example, if the bar graph shows the following:

1. LO/DO LED bar = On
2. High LED bar = Off
3. Unnamed LED bar = Off
4. Stnd LED bar = On
5. Unnamed LED bar = Off
6. Low LED bar = Off
7. Delay LED bar = Off

then the sensor is set to light operate, standard sensitivity, and has no active delay (see ["Figure: Features" on page 4](#)).

Chapter Contents

2.1 Mount the Device.....5
 2.2 Wiring.....5

Chapter 2 Installation Instructions

2.1 Mount the Device

1. If a bracket is needed, mount the device onto the bracket.
2. Mount the device (or the device and the bracket) to the machine or equipment at the desired location. Do not tighten the mounting screws at this time.
3. Check the device alignment.
 The face of the sensor must be perpendicular to the reflector.
4. Tighten the mounting screws to secure the device (or the device and the bracket) in the aligned position.

2.2 Wiring

Quick disconnect wiring diagrams are functionally identical.

Figure 2. Channel 2 as PNP discrete

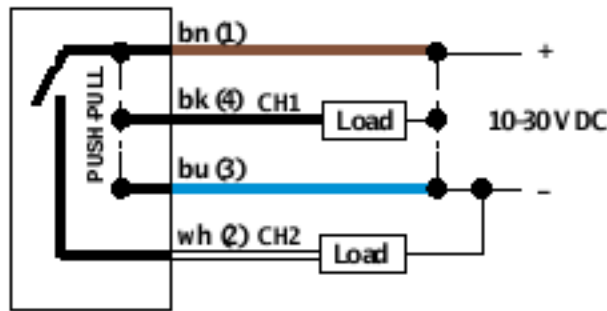
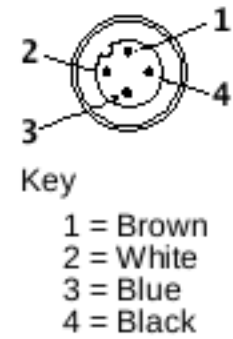
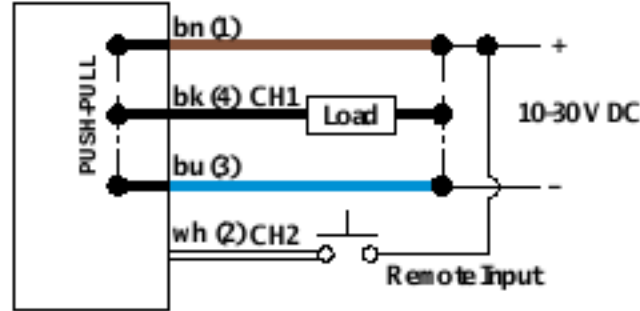

Figure 3. Channel 2 as remote input



Chapter Contents

3.1 TEACH Button Overview.....6
 3.2 Remote Input.....7
 3.3 TEACH Procedures.....7
 3.4 Reset the Sensor to Factory Default Settings.....14

Chapter 3 Configuration Instructions

Quickly set up and configure the sensor using the push button on the sensor, a remote input wire, or IO-Link. The following instructions use the push button or the remote input wire. See p/n 243322 for IO-Link information.

3.1 TEACH Button Overview

Press the TEACH button to configure the sensor.

See "TEACH Procedures" on page 7 for detailed instructions.

Figure 4. TEACH Button Chart

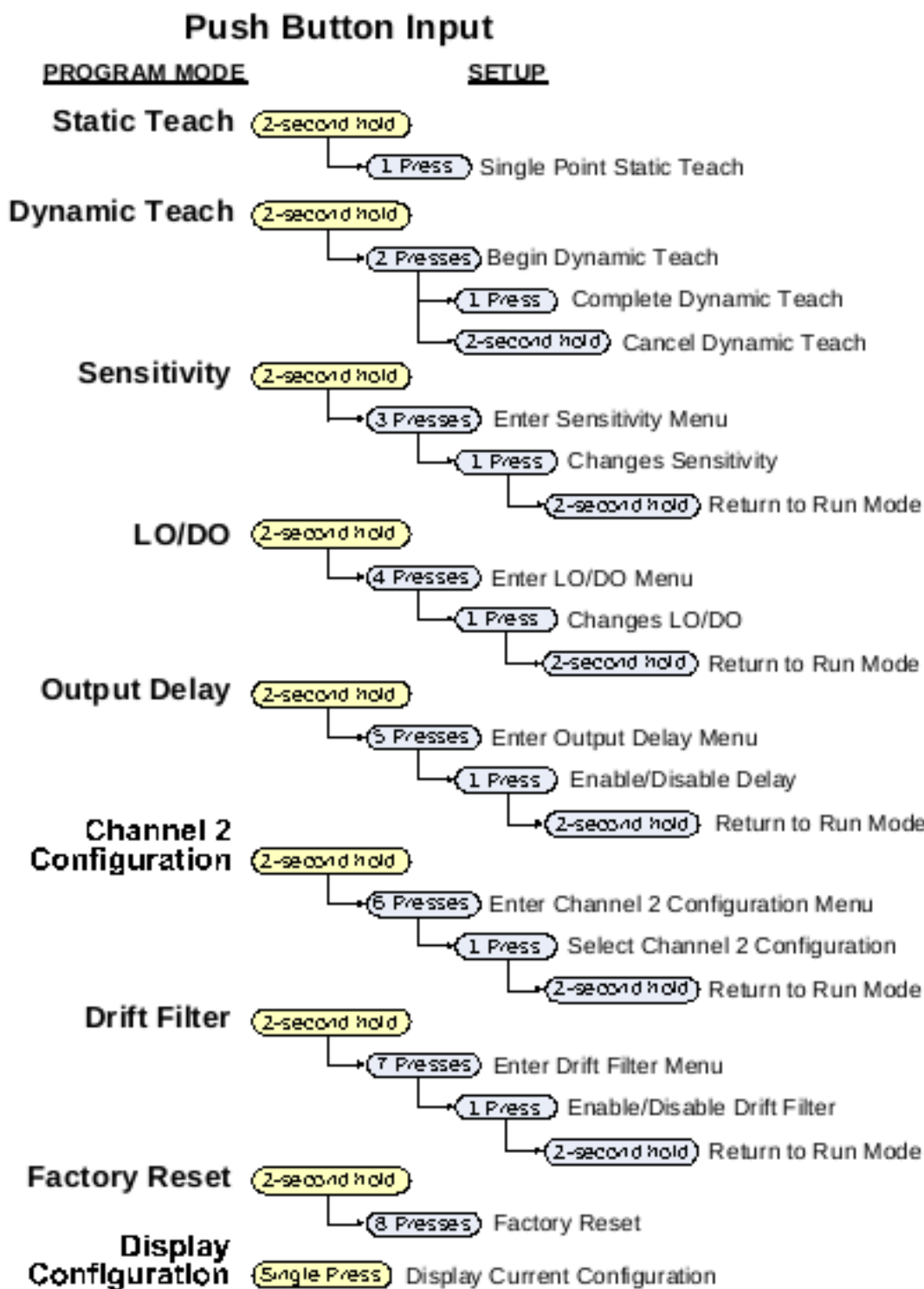

3.2 Remote Input

The remote input provides limited programming options. When the polarity selection is push-pull or PNP, remote input is Active High. When the polarity selection is NPN, remote input is Active Low.

For Active High, connect the white input wire to V+ (10 V DC to 30 V DC), with a remote switch connected between the wire and V+. For Active Low, connect the white input wire to ground (0 V DC) with a remote switch connected between the wire and ground.

Pulse the remote input according to the diagram and the instructions provided in this manual.

The length of the individual programming pulses is equal to the value T: 0.04 seconds ≤ T ≤ 0.8 seconds

Figure 5. Remote Input Map

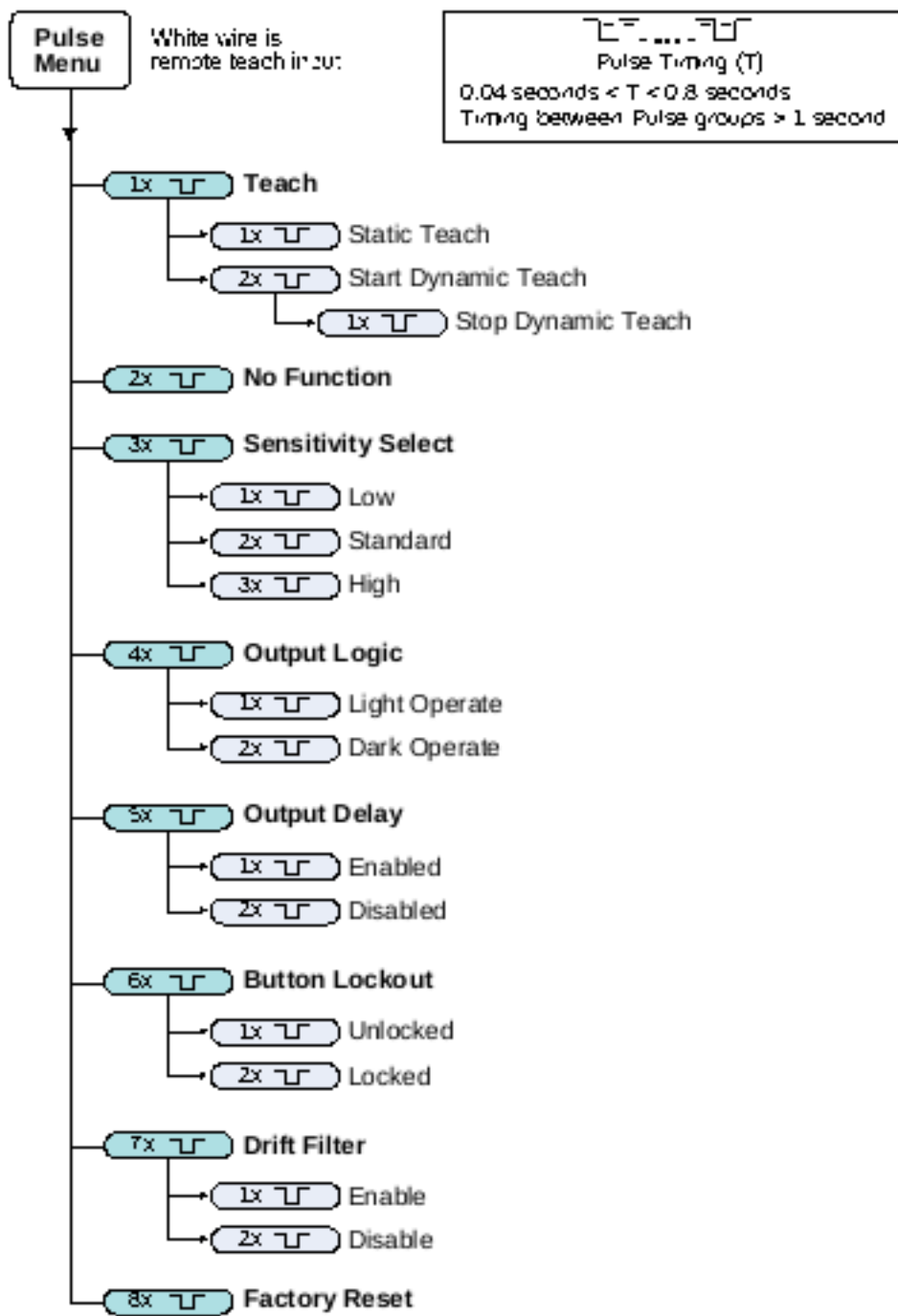

3.3 TEACH Procedures

Use the following procedures to configure the sensor.

To exit a TEACH procedure, press and hold the TEACH button for longer than two seconds.

3.3.1 Static TEACH

Use the following procedure to statically configure the sensor.

The Static TEACH method configures the sensor to detect beam blockage in excess of the taught condition. For example, if the sensor is above a surface and is taught with no part of the beam blocked, then the sensor will detect when a large enough object is present anywhere in the beam.

Alternatively, if the sensor is mounted slightly below the plane of a surface, some of the beam will be blocked by the surface. Teaching the sensor in this setup sets the threshold of the sensor so that the surface is accounted for, and additional beam blockage from objects on the surface will be detected.

If the sensor is taught with a surface present (part of the beam is blocked) and then the sensor is moved so that no part of the beam is blocked, the sensor will only detect when light equivalent to the taught condition (the surface) plus a minimum object is subsequently blocked.

1. Make sure the sensor is properly aligned with the retroreflector.
2. Enter configuration mode.

Method	Action	Result
Push Button	Press and hold the TEACH button for 2 seconds.	The green (power) LED flashes.
Remote Input	Pulse the remote input once.	

3. Configure the sensor.

Method	Action	Result
Push Button	Press the TEACH button once.	Configuration Accepted The green and amber LEDs flash twice and the sensor returns to Run mode.
Remote Input	Pulse the remote input once.	Configuration Not Accepted The amber LED flashes three times and the sensor returns to Run mode.

3.3.2 Dynamic TEACH

Use the following procedure to dynamically configure the sensor.

When using the Dynamic TEACH method, the sensor learns during actual sensing conditions, taking multiple samples and automatically setting the threshold at the optimum level. This is the recommended TEACH method for most applications.

Using the Dynamic TEACH method is an effective way to account for most belt flutter, seams, or other undesirable targets within the sensing beam. The Dynamic TEACH method sets the sensor threshold to ignore most belt imperfections and reduces the likelihood of false detections.

To cancel, press and hold the button or the remote input for two seconds during the process.

1. Make sure the sensor is properly aligned with the retroreflector.
2. Enter configuration mode.

Method	Action	Result
Push Button	Press and hold the TEACH button for 2 seconds.	The green (power) LED flashes.
Remote Input	Pulse the remote input once.	

3. Start the dynamic TEACH.

Method	Action	Result
Push Button	Press the TEACH button twice.	The bar graph LEDs cycle up and down the graph, the green LED is on, and the amber LED is off.
Remote Input	Pulse the remote input twice.	



4. End the TEACH process.

Method	Action	Result
Push Button	Press the TEACH button once.	Configuration Accepted
Remote Input	Pulse the remote input line once.	The green and amber LEDs flash twice and the sensor returns to Run mode.
		Configuration Not Accepted
		The amber LED flashes three times and the sensor returns to Run mode.

3.3.3 Adjust the Sensitivity

Use the following procedure to adjust the sensitivity of the sensor to detect smaller targets or to increase performance in dirty environments.

Table 1. Sensitivity Options

LED Bar(s) On	Setting	LED Bar(s) On	Setting	LED Bar(s) On	Setting
High Sensitivity 	High	Std Sensitivity 	Standard (default)	Low Sensitivity 	Low

1. Enter configuration mode.

Method	Action	Result
Push Button	Press and hold the TEACH button for 2 seconds.	The green (power) LED flashes.
Remote Input	No action required.	N/A

2. Access the sensitivity settings.

Method	Action	Result
Push Button	Press the TEACH button three times.	By default, the middle (Std) LED on the bar graph is on. See "Sensitivity Options " on page 9.
Remote Input	Pulse the remote input three times.	The green (power) LED flashes.

3. Select the desired level. Three settings are available, ranging from low to high.

Method	Action	Result
Push Button	Press the TEACH button to move through the settings on the bar graph until the LED at the desired level is on.	The LED on the desired level is on. See "Sensitivity Options " on page 9.

Continued on page 10

Continued from page 9

Method	Action	Result								
Remote Input	Pulse the remote input to select the desired level.	The green and amber LEDs flash twice and the sensor returns to Run mode.								
	<table border="1"> <thead> <tr> <th>Pulses</th> <th>Sensitivity Level</th> </tr> </thead> <tbody> <tr> <td>1</td> <td>Low</td> </tr> <tr> <td>2</td> <td>Standard</td> </tr> <tr> <td>3</td> <td>High</td> </tr> </tbody> </table>		Pulses	Sensitivity Level	1	Low	2	Standard	3	High
	Pulses		Sensitivity Level							
	1		Low							
2	Standard									
3	High									

4. Confirm the selection.

Method	Action	Result
Push Button	Press and hold the TEACH button for 2 seconds.	The green and amber LEDs flash twice and the sensor returns to Run mode.
Remote Input	No action required.	N/A

3.3.4 Set Light Operate (LO) or Dark Operate (DO)

Set the output of the sensor to light operate or dark operate, depending on what is needed for the application.



Light Operate

In light operate (LO) mode, the output is ON when the target returns the same or more light to the sensor and OFF when the sensor detects less light than the configured/taught target.

Dark Operate

In dark operate (DO) mode, the output is ON when the target returns less light to the sensor than the configured target and OFF when the sensor detects more light than the configured/taught target.

Table 2. LO/DO Options

LED Bar(s) On	Setting	LED Bar(s) On	Setting
	Light Operate		Dark Operate (default)

1. Enter configuration mode.

Method	Action	Result
Push Button	Press and hold the TEACH button for 2 seconds.	The green (power) LED flashes.
Remote Input	No action required.	N/A

2. Access the LO/DO setting.

Method	Action	Result
Push Button	Press the TEACH button four times.	The LO/DO LED (top bar) on the bar graph shows the current setting. See "LO/DO Options" on page 10.
Remote Input	Pulse the remote input four times.	The green (power) LED flashes.

3. Select the desired setting.

Method	Action	Result						
Push Button	Press the TEACH button to cycle between LO and DO to select the desired setting.	The LO/DO LED (top bar) on the bar graph shows the selected setting. See "LO/DO Options" on page 10.						
Remote Input	Pulse the remote input to select the desired setting.	The green and amber LEDs flash twice and the sensor returns to Run mode.						
	<table border="1"> <thead> <tr> <th>Pulses</th> <th>Setting</th> </tr> </thead> <tbody> <tr> <td>1</td> <td>Light Operate</td> </tr> <tr> <td>2</td> <td>Dark Operate</td> </tr> </tbody> </table>		Pulses	Setting	1	Light Operate	2	Dark Operate
	Pulses		Setting					
1	Light Operate							
2	Dark Operate							

4. Confirm the selection.

Method	Action	Result
Push Button	Press and hold the TEACH button for 2 seconds.	The LEDs on the bar graph show the current selection. The green and amber LEDs flash twice and the sensor returns to Run mode.
Remote Input	No action required.	N/A

3.3.5 Set a Delay

Use the following procedure to turn the delay function on or off.

The default delay time is a 10 ms on delay and a 10 ms off delay. The delay time can be changed via IO-Link. The default function is inactive.

Table 3. Delay Options

LED Bar(s) On	Setting	LED Bar(s) On	Setting
Delay 	Delay function active	None 	Delay function inactive (default)

1. Enter configuration mode.

Method	Action	Result
Push Button	Press and hold the TEACH button for 2 seconds.	The green (power) LED flashes.
Remote Input	No action required.	N/A

2. Access the Delay setting.

Method	Action	Result
Push Button	Press the TEACH button five times.	The Delay LED (bottom bar) on the bar graph shows the current setting. See "Delay Options" on page 11.
Remote Input	Pulse the remote input five times.	The green (power) LED flashes.

3. Select the desired setting.

Method	Action	Result
Push Button	Press the TEACH button to cycle between on and off to select the desired setting.	The Delay LED (bottom bar) on the bar graph shows the selected setting. See "Delay Options" on page 11.

Continued on page 12

Continued from page 11

Method	Action	Result						
Remote Input	Pulse the remote to select the desired setting.	The green and amber LEDs flash twice and the sensor returns to Run mode.						
	<table border="1"> <thead> <tr> <th>Pulses</th> <th>Setting</th> </tr> </thead> <tbody> <tr> <td>1</td> <td>Enabled</td> </tr> <tr> <td>2</td> <td>Disabled</td> </tr> </tbody> </table>		Pulses	Setting	1	Enabled	2	Disabled
	Pulses		Setting					
1	Enabled							
2	Disabled							

4. Confirm the selection.

Method	Action	Result
Push Button	Press and hold the TEACH button for 2 seconds.	The LEDs on the bar graph show the current selection. The green and amber LEDs flash twice and the sensor returns to Run mode.
Remote Input	No action required.	N/A







3.3.6 Input/Output Configuration for Channel 2

Use the following procedure to select the function for Channel 2.

This procedure is for the push button only. Remote input does not apply; see ["Remote Input" on page 7](#).

The default output is Complementary.

Table 4. Configuration Options

LED Bar(s) On	Setting	LED Bar(s) On	Setting
Middle three 	Complementary (default) The output on Channel 2 is opposite of the output on Channel 1. For example, if the output on Channel 1 is active, then the output on Channel 2 is inactive.	Top and bottom 	Channel 2 disabled Channel 2 has no function and is effectively disabled.
Bottom 	Health The B25 monitors deviation from the taught condition. The health output is active after a successful configuration. If the signal quality deviates far enough from the taught conditions, the health output turns off. This output is not the same as a detection condition. Configure the health output threshold via the alarm threshold setting in IO-Link.	Middle and bottom 	Remote input Channel 2 accepts remote input commands as described in "TEACH Procedures" on page 7 .
Top 	Alarm The inverse of health, alarm has the output inactive until the alarm threshold is reached, at which point the output becomes active.	Top and middle 	Detection output The output on Channel 2 is the same as Channel 1. For example, if the output on Channel 1 is active, then output on Channel 2 is also active.

1. Enter configuration mode.

Action	Result
Press and hold the TEACH button for 2 seconds.	The green (power) LED flashes.

2. Access the Channel 2 Configuration settings.

Action	Result
Press the TEACH button six times.	The LEDs on the bar graph show the current setting and the green (power) LED flashes. See "Configuration Options" on page 12.

3. Select the desired setting.

Action	Result
Press the TEACH button to cycle through the options and select the desired setting.	The LEDs on the bar graph show the selected setting and the green (power) LED flashes. See "Configuration Options" on page 12.

4. Confirm the selection.

Action	Result
Press and hold the TEACH button for 2 seconds.	The LEDs on the bar graph show the current selection. The green and amber LEDs flash twice and the sensor returns to Run mode.



3.3.7 Enable or Disable the Drift Filter

Use the following procedure to enable or disable the drift filter.

The drift filter allows the sensor to compensate, within its limits, for environmental changes, such as dust accumulation or temperature variations. If the sensor sees light blocked for a period of time without reaching the detection threshold, it automatically adjusts to maintain the ability to detect targets. If enough light is blocked for detection to occur, the sensor does not compensate for what is present in the beam.

The default is enabled.

Table 5. Configuration Options

LED Bar(s) On	Setting	LED Bar(s) On	Setting
Top three 	Enabled (default)	Bottom three 	Disabled

1. Enter configuration mode.

Method	Action	Result
Push Button	Press and hold the TEACH button for 2 seconds.	The green (power) LED flashes.
Remote Input	No action required.	N/A

2. Access the Drift Filter setting.

Method	Action	Result
Push Button	Press the TEACH button seven times.	The green (power) LED is on, the amber (output status) LED is off, and the bar graph shows the current setting. See "Configuration Options" on page 13.
Remote Input	Pulse the remote input seven times.	The green (power) LED flashes.

3. Select the desired setting.

Method	Action	Result						
Push Button	Press the TEACH button to cycle between enabled and disabled to select the desired setting.	The green (power) LED flashes, the amber (output status) LED is off, and the bar graph shows the selected setting. See "Configuration Options" on page 13.						
Remote Input	Pulse the remote to select the desired setting.	The green and amber LEDs flash twice and the sensor returns to Run mode.						
	<table border="1"> <thead> <tr> <th>Pulses</th> <th>Setting</th> </tr> </thead> <tbody> <tr> <td>1</td> <td>Enabled</td> </tr> <tr> <td>2</td> <td>Disabled</td> </tr> </tbody> </table>		Pulses	Setting	1	Enabled	2	Disabled
	Pulses		Setting					
1	Enabled							
2	Disabled							

4. Confirm the selection.

Method	Action	Result
Push Button	Press and hold the TEACH button for 2 seconds.	The LEDs on the bar graph show the current selection. The green and amber LEDs flash twice and the sensor returns to Run mode.
Remote Input	No action required.	N/A

3.4 Reset the Sensor to Factory Default Settings

To reset the sensor to factory default, eight-pulse the remote input or press the TEACH button eight times.

The bar graph, the green LED, and the amber LED flash twice and the sensor returns to Run mode.

3.4.1 Factory Default Settings

Setting	Factory Default
Sensitivity	Standard
Light Operate/Dark Operate	Dark Operate (DO)
Delay function	Disabled
Delay timing	10 ms on delay 10 ms off delay
Polarity	PNP (Polarity is changed via IO-Link and does not change with a factory reset)
Channel 2 output configuration	Complementary
Drift filter	Enabled

Chapter Contents

Chapter 4 IO-Link Interface

IO-Link is a point-to-point communication link between a master device and sensor. Use IO-Link to parameterize sensors and transmit process data automatically.

For the latest IO-Link protocol and specifications, see www.io-link.com.

Each IO-Link device has an IODD (IO Device Description) file that contains information about the manufacturer, article number, functionality etc. This information can be easily read and processed by the user. Each device can be unambiguously identified via the IODD as well as via an internal device ID. Download the B25's IO-Link IODD package (p/n 242307) from Banner Engineering's website at www.bannerengineering.com.

Banner has also developed Add On Instruction (AOI) files to simplify ease-of-use between the B25, multiple third-party vendors' IO-Link masters, and the Logix Designer software package for Rockwell Automation PLCs. Three types of AOI files for Rockwell Allen-Bradley PLCs are listed below. These files and more information can be found at www.bannerengineering.com.

Process Data AOIs—These files can be used alone, without the need for any other IO-Link AOIs. The job of a Process Data AOI is to intelligently parse out the Process Data word(s) in separate pieces of information. All that is required to make use of this AOI is an EtherNet/IP connection to the IO-Link Master and knowledge of where the Process Data registers are located for each port.

Parameter Data AOIs—These files require the use of an associated IO-Link Master AOI. The job of a Parameter Data AOI, when working in conjunction with the IO-Link Master AOI, is to provide quasi-realtime read/write access to all IO-Link parameter data in the sensor. Each Parameter Data AOI is specific to a given sensor or device.

IO-Link Master AOIs—These files require the use of one or more associated Parameter Data AOIs. The job of an IO-Link Master AOI is to translate the desired IO-Link read/write requests, made by the Parameter Data AOI, into the format a specific IO-Link Master requires. Each IO-Link Master AOI is customized for a given brand of IO-Link Master.

Add and configure the relevant Banner IO-Link Master AOI in your ladder logic program first; then add and configure Banner IO-Link Device AOIs as desired, linking them to the Master AOI as shown in the relevant AOI documentation.

Chapter Contents

5.1 Dimensions17

Chapter 5 Specifications

- Supply Voltage
10 V DC to 30 V DC
- Supply Protection Circuitry
Protected against reverse polarity and transient overvoltages
- Power and Current Consumption
Power Consumption: < 1.2 Watt
- Output
Push-Pull with IO-Link, PNP
- Output Rating
Current rating: 50 mA maximum

Black wire specifications per configuration		
IO-Link Push/Pull	Output High:	$\geq V_{supply} - 2.5\text{ V}$
	Output Low:	$\leq 2.5\text{ V}$
PNP	Output High:	$\geq V_{supply} - 2.5\text{ V}$
	Output Low:	$\leq 1\text{ V (loads } \leq \text{Meg}\Omega)$
NPN	Output High:	$\geq V_{supply} - 2.5\text{ V (loads } \leq 50\text{ k}\Omega)$
	Output Low:	$\leq 2.5\text{ V}$

White wire specifications per configuration		
PNP	Output High:	$\geq V_{supply} - 2.5\text{ V}$
	Output Low:	$\leq 2.5\text{ V (loads } \leq 70\text{ k}\Omega)$
NPN	Output High:	$\geq V_{supply} - 2.5\text{ V (loads } \leq 70\text{ k}\Omega)$
	Output Low:	$\leq 2.5\text{ V}$

- IO-Link Interface
IODD files: Provides all programming options of the display, plus additional functionality. See p/n 243322 for IO-Link reference information.
 - Sensing Beam
Visible red LED, 630 nm
 - Switching Frequency
1 kHz
 - Sensing Range
0 m to 2 m (0 ft to 6.6 ft)⁽²⁾
 - Distance to Reflector
300 mm to 2 m (11.8 in to 6.6 ft)
- ⁽²⁾ Range with a BRT-S1X51BM reflector.

- Response Speed
 $\leq 0.5\text{ ms}$
- Minimum Detectable Object⁽³⁾

Sensitivity	Sensor to Reflector Distance	Typical Minimum Object
Standard	2 m	5 mm
Standard	1.5 m	4 mm
Standard	1.1 m	3 mm

- Delay at Power-up
1.25 seconds
- Pin 2 Configuration
Disabled, Health, Alarm, Detection, Complementary, Remote Input
- Warm-Up Time
15 minutes
- Indication
Green Indicator LED: Power
Amber Indicator LED: Discrete Signal
7 Amber LED Bars: Beam blockage from taught state
- Construction
Housing: PC/ABS
Window: plastic
- Connections
100 mm (6 in) PVC-jacketed cable with a 4-pin M12 quick-disconnect connector
- Operating Conditions
Operating Temperature: $-30^{\circ}\text{ C to }+60^{\circ}\text{ C (-22}^{\circ}\text{ F to }+140^{\circ}\text{ F)}$
Storage Temperature: $-40^{\circ}\text{ C to }+70^{\circ}\text{ C (-40}^{\circ}\text{ F to }+158^{\circ}\text{ F)}$
- Environmental Rating
IP67
- Certifications



⁽³⁾ Minimum object specifications are defined at 20°C and require a BRT-S1X51BM reflector.

5.1 Dimensions

All measurements are listed in millimeters, unless noted otherwise. The measurements provided are subject to change.

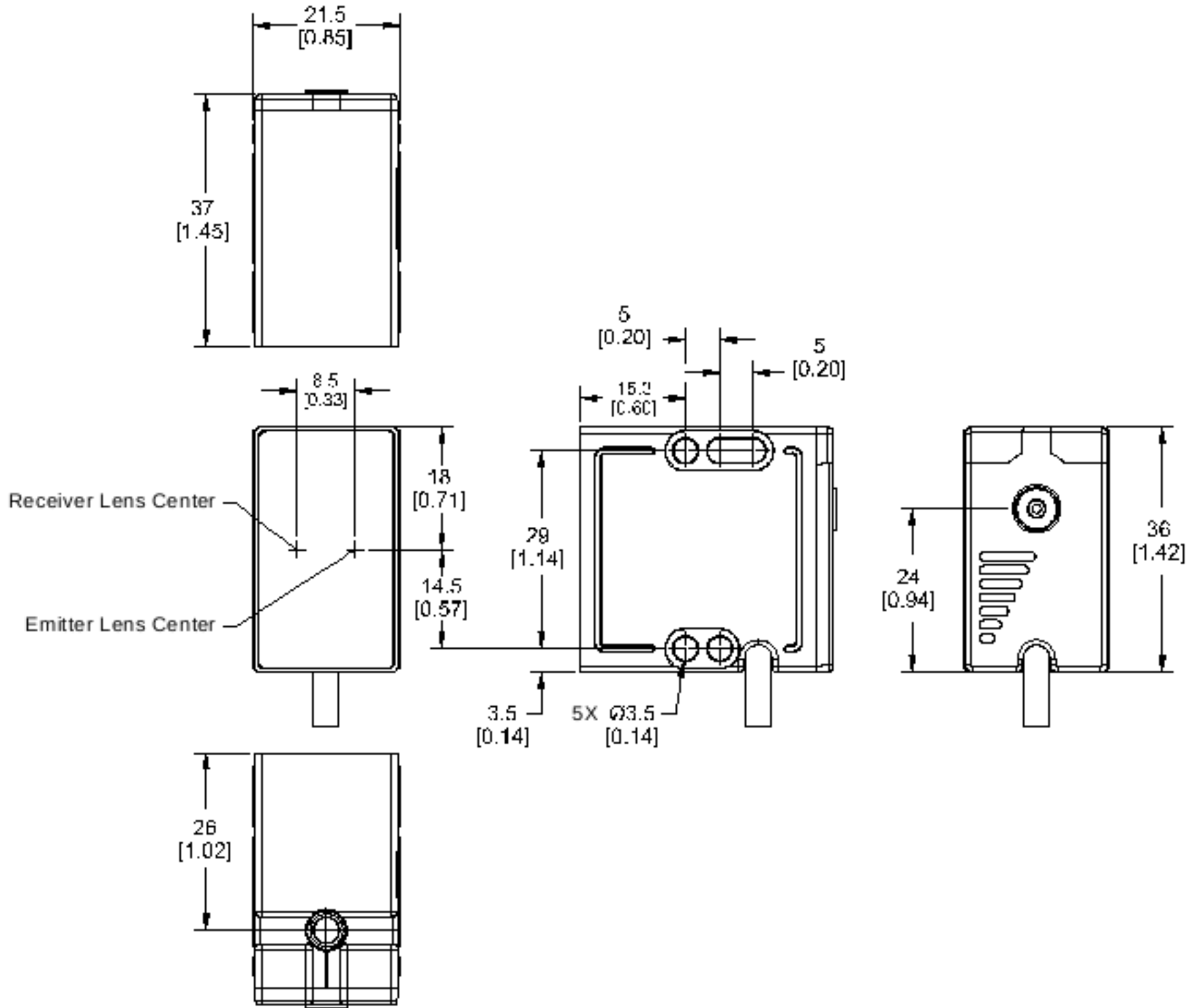

Chapter Contents

6.1 Cordsets.....18
 6.2 Brackets.....19
 6.3 Reflectors.....19

Chapter 6 Accessories

6.1 Cordsets

4-Pin Single-Ended M12 Female Cordsets				
Model	Length	Style	Dimensions	Pinout (Female)
MQDC-406	2 m (6.56 ft)	Straight		
MQDC-415	5 m (16.4 ft)			
MQDC-430	9 m (29.5 ft)			
MQDC-450	15 m (49.2 ft)			
MQDC-406RA	2 m (6.56 ft)	Right-Angle		
MQDC-415RA	5 m (16.4 ft)			
MQDC-430RA	9 m (29.5 ft)			
MQDC-450RA	15 m (49.2 ft)			

1 = Brown
 2 = White
 3 = Blue
 4 = Black
 5 = Not used

4-Pin Double-Ended M12 Female to M12 Male Cordsets				
Model	Length	Style	Dimensions	Pinout
MQDEC-40155	0.31 m (1 ft)	Male Straight/Female Straight		<p>Female</p> <p>Male</p>
MQDEC-40355	0.91 m (2.99 ft)			
MQDEC-40655	1.83 m (6 ft)			
MQDEC-41255	3.66 m (12 ft)			
MQDEC-41555	4.58 m (15 ft)			
MQDEC-42055	6.10 m (20 ft)			
MQDEC-43055	9.14 m (30.2 ft)			
MQDEC-45055	15.2 m (49.9 ft)			

1 = Brown
 2 = White
 3 = Blue
 4 = Black

6.2 Brackets

SMBB25P

- Zinc plated, Cold Rolled Steel

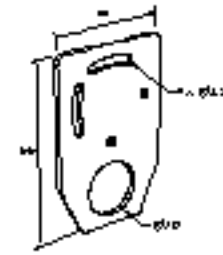

SMBB25RA

- Zinc plated, Cold Rolled Steel

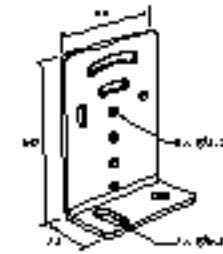

6.3 Reflectors

BRT-51X51BM

- Square, acrylic target
- Reflectivity Factor: 1.5
- Temperature: $-20\text{ }^{\circ}\text{C}$ to $+50\text{ }^{\circ}\text{C}$ ($-4\text{ }^{\circ}\text{F}$ to $+122\text{ }^{\circ}\text{F}$)
- Micro-prism geometry
- Optional brackets are available
- Approximate size: 51 mm \times 51 mm



Chapter Contents

7.1 Supporting Documentation.....20
 7.2 Troubleshooting.....20
 7.3 Clean Sensor with Compressed Air and Lint-Free Cloth.....20
 7.4 Repairs.....20
 7.5 Contact Us.....21
 7.6 Banner Engineering Corp Limited Warranty.....21

Chapter 7 Product Support

7.1 Supporting Documentation

The following documentation is available at www.bannerengineering.com.

Part number	Document Name
243322	IO-Link Data Reference Guide: B25 Wide Beam
242307	B25 IODD File
B_51934077	B25 IO-Link AOI File

7.2 Troubleshooting

If the configuration is not accepted during a TEACH procedure (the amber LED flashes three times), see the following possible reasons why.

During a Static TEACH: Not enough returned light results in the configuration not being accepted. For example, the reflector is not in place.

During a Dynamic TEACH:

- Not enough returned light at the start of the TEACH process causes the configuration to be rejected immediately. For example, not having a reflector in place.
- If the TEACH process starts with the reflector in place, but then too much light is blocked, the configuration will not be accepted. For example, starting the TEACH process, removing the reflector and returning it, and then completing the TEACH process.

7.3 Clean Sensor with Compressed Air and Lint-Free Cloth

Handle the sensor with care during installation and operation. Sensor windows soiled by fingerprints, dust, water, oil, etc. may create stray light that may degrade the peak performance of the sensor. Blow dust from the sensor using filtered, compressed air, then clean as necessary using a lint-free cloth.

7.4 Repairs

Contact Banner Engineering for troubleshooting of this device. Do not attempt any repairs to this Banner device; it contains no field-replaceable parts or components. If the device, device part, or device component is determined to be defective by a Banner Applications Engineer, they will advise you of Banner’s RMA (Return Merchandise Authorization) procedure.

IMPORTANT: If instructed to return the device, pack it with care. Damage that occurs in return shipping is not covered by warranty.

You may be asked to provide the configuration file and the data log file (.cfg) to aid in troubleshooting.

7.5 Contact Us

Banner Engineering Corp. headquarters is located at: 9714 Tenth Avenue North | Plymouth, MN 55441, USA | Phone: + 1 888 373 6767

For worldwide locations and local representatives, visit www.bannerengineering.com.

7.6 Banner Engineering Corp Limited Warranty

Banner Engineering Corp. warrants its products to be free from defects in material and workmanship for one year following the date of shipment. Banner Engineering Corp. will repair or replace, free of charge, any product of its manufacture which, at the time it is returned to the factory, is found to have been defective during the warranty period. This warranty does not cover damage or liability for misuse, abuse, or the improper application or installation of the Banner product.

THIS LIMITED WARRANTY IS EXCLUSIVE AND IN LIEU OF ALL OTHER WARRANTIES WHETHER EXPRESS OR IMPLIED (INCLUDING, WITHOUT LIMITATION, ANY WARRANTY OF MERCHANTABILITY OR FITNESS FOR A PARTICULAR PURPOSE), AND WHETHER ARISING UNDER COURSE OF PERFORMANCE, COURSE OF DEALING OR TRADE USAGE.

This Warranty is exclusive and limited to repair or, at the discretion of Banner Engineering Corp., replacement. IN NO EVENT SHALL BANNER ENGINEERING CORP. BE LIABLE TO BUYER OR ANY OTHER PERSON OR ENTITY FOR ANY EXTRA COSTS, EXPENSES, LOSSES, LOSS OF PROFITS, OR ANY INCIDENTAL, CONSEQUENTIAL OR SPECIAL DAMAGES RESULTING FROM ANY PRODUCT DEFECT OR FROM THE USE OR INABILITY TO USE THE PRODUCT, WHETHER ARISING IN CONTRACT OR WARRANTY, STATUTE, TORT, STRICT LIABILITY, NEGLIGENCE, OR OTHERWISE.

Banner Engineering Corp. reserves the right to change, modify or improve the design of the product without assuming any obligations or liabilities relating to any product previously manufactured by Banner Engineering Corp. Any misuse, abuse, or improper application or installation of this product or use of the product for personal protection applications when the product is identified as not intended for such purposes will void the product warranty. Any modifications to this product without prior express approval by Banner Engineering Corp will void the product warranties. All specifications published in this document are subject to change; Banner reserves the right to modify product specifications or update documentation at any time. Specifications and product information in English supersede that which is provided in any other language. For the most recent version of any documentation, refer to: www.bannerengineering.com.

For patent information, see www.bannerengineering.com/patents.

