

K50 Pro Select Optical Sensor Product Manual



Original Instructions

p/n: 240397 Rev. B

19-Feb-25

© Banner Engineering Corp. All rights reserved. www.bannerengineering.com

Contents

Chapter 1 Features.....	3
Models	3
Overview.....	3
Class 1 Laser Description and Safety Information	4
 Chapter 2 Wiring.....	 6
 Chapter 3 Configuring a Sensor	 7
Remote Input	7
Remote Teach	7
Teach Modes and Operation.....	8
Object Mode (default)	8
Background Mode	8
Window Mode	9
Reset the Sensor to Factory Defaults.....	9
Reset Using the Banner Pro Editor Software	9
Reset Using the Remote Input	9
Factory Default Settings via Remote Teach Mode.....	9
 Chapter 4 Alternate Modes through Pro Editor.....	 11
Detection	11
Distance	11
Coarse Distance	12
Advanced Settings.....	12
 Chapter 5 Specifications	 14
FCC Part 15 Class B for Unintentional Radiators.....	15
Industry Canada ICES-003(B)	15
Dimensions	16
Beam Pattern.....	16
 Chapter 6 Accessories.....	 17
Pro Editor Hardware	17
Cordsets	18
Brackets	18
Elevated Mount System.....	20
 Chapter 7 Product Support and Maintenance	 21
Clean with Mild Detergent and Water	21
Repairs	21
Contact Us	21
Banner Engineering Corp Limited Warranty	21

Chapter Contents

Models 3
 Overview 3
 Class 1 Laser Description and Safety Information 4

Chapter 1 Features

50 mm Programmable Multicolor RGB Optical Sensor and Indicator

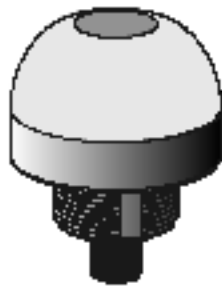

- Programmable using Banner's Pro Editor software and Pro Converter Cable
- Three default colors in one device (Green, Red, Yellow)
- Devices are completely self-contained—no controller needed
- Teachable modes with color feedback for ease of use
- Touchless activation removes the need for physical force to activate
- Rugged IP66, IP67, IP69K per ISO 20653 and UL Type 4X and UL Type 13 design
- Resistant to ambient light, EMI, and RFI interference
- Sensing and indication in one device
- Bright, uniform indicator light
- Translucent polycarbonate dome
- Bimodal inputs and output (PNP/NPN), depending on source wiring

WARNING:



- Do not use this device for personnel protection
- Using this device for personnel protection could result in serious injury or death.
- This device does not include the self-checking redundant circuitry necessary to allow its use in personnel safety applications. A device failure or malfunction can cause either an energized (on) or de-energized (off) output condition.

Models

Family	Style	Color and Input	Connector ⁽¹⁾
K50	PSAF1000	GRY3	Q
	PSAF1000 = 1000 mm Adjustable Field Sensor	GRY3 = RGB Multicolor (3 colors)	Q = Integral 5-pin M12 male quick-disconnect connector

Overview

The K50 Pro Select Optical Sensor is an adjustable field optical sensor that can detect a wide variety of materials and objects.

Configure the sensor using software or remote input wires to sense objects up to a specific distance, ignoring objects beyond this distance (background suppression), or within a windowed range.

⁽¹⁾ Models with a quick-disconnect connector require a mating cordset.

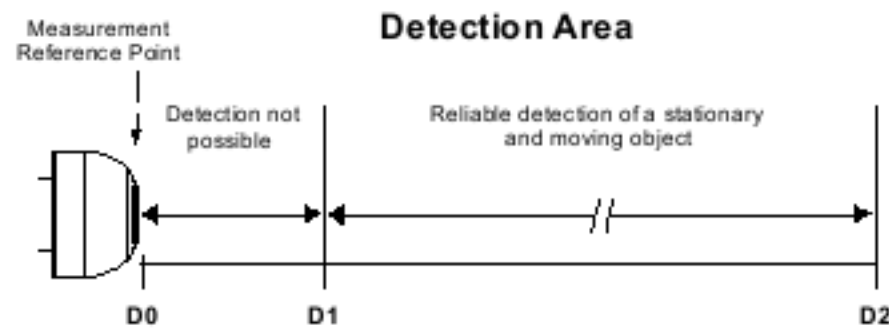

Model	D0 (mm)	Switch Point D1 (mm)	Switch Point D2 (mm)
K50PSAF1000GRY3Q	0	20	1000

Class 1 Laser Description and Safety Information



Laser light. Do not stare into the beam.

Complies with 21 CFR 1040.10 and 1040.11 except for deviations pursuant to Laser Notice No. 56, dated May 8, 2019.

**CLASS 1
LASER PRODUCT**

CAUTION:



- Never stare directly into the sensor lens.
- Laser light can damage your eyes.
- Avoid placing any mirror-like object in the beam. Never use a mirror as a retroreflective target.

CAUTION:



- Return defective units to the manufacturer.
- Use of controls or adjustments or performance of procedures other than those specified herein may result in hazardous radiation exposure.
- Do not attempt to disassemble this sensor for repair. A defective unit must be returned to the manufacturer.

CAUTION:



- Ne regardez jamais directement la lentille du capteur.
- La lumière laser peut endommager la vision.
- Évitez de placer un objet réfléchissant (de type miroir) dans la trajectoire du faisceau. N'utilisez jamais de miroir comme cible rétro-réfléchissante.

CAUTION:



- Tout dispositif défectueux doit être renvoyé au fabricant.
- L'utilisation de commandes, de réglages ou de procédures autres que celles décrites dans le présent document peut entraîner une exposition dangereuse aux radiations.
- N'essayez pas de démonter ce capteur pour le réparer. Tout dispositif défectueux doit être renvoyé au fabricant.

Class 1 lasers are lasers that are safe under reasonably foreseeable conditions of operation, including the use of optical instruments for intrabeam viewing.

Complies with IEC 60825-1:2014 and EN 60825-1:2014+A11:2021.

For safe laser use:

- Do not stare at the laser.
- Do not point the laser at a person's eye.
- Mount open laser beam paths either above or below eye level, where practical.
- Terminate the beam emitted by the laser product at the end of its useful path.

Chapter Contents

Chapter 2 Wiring

GRY3 Wiring Diagrams

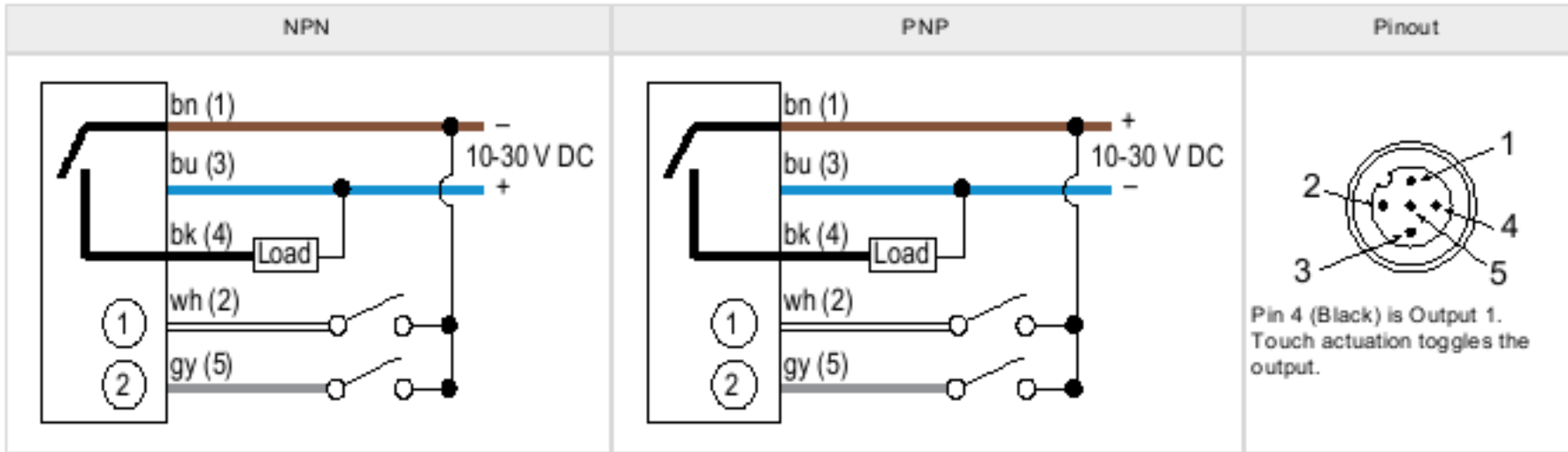

GRY3 Multicolor Color/Function Definition

	Green	Yellow	Red
Input 1	X	X	
Input 2		X	X

Chapter Contents

Remote Input..... 7
 Reset the Sensor to Factory Defaults 9
 Reset Using the Banner Pro Editor Software 9
 Reset Using the Remote Input 9

Chapter 3 Configuring a Sensor

The K50 Pro Select Optical Sensor has three Teach modes. These modes are indicated with a Teach Status color.

The Signal Level color flashes in between the Teach Status color. The color of the Signal Level depends on the signal strength of the target:

- Green: Best signal, accepts Teach
- Yellow: Acceptable signal, can accept Teach
- Red: Poor signal, rejects Teach

Remote Input

Use the remote input to program the sensor remotely.

The remote input provides limited programming options and is Active High in PNP mode (V+ to brown wire), or Active Low in NPN mode (V+ to blue wire). For Active High, pulse the gray or yellow input wire to V+ (10 V DC to 30 V DC). For Active Low, pulse the gray or yellow input wire to ground (0 V DC).

The remote input wire is enabled by default. Pulse the remote input wire 7 times or use the Banner Pro Editor software to enable or disable the feature. When the remote input feature is enabled, pulse the remote input according to the diagram and the instructions provided in this manual. Remote teach can also be performed using the button on the Pro Converter Cable.

The length of the individual programming pulses is equal to the value T: 0.04 seconds ≤ T ≤ 0.8 seconds.

Exit remote programming modes by cycling power or by waiting for 30 seconds.

NOTE: If a factory reset is performed through the Banner Pro Editor Software, the remote input wire becomes enabled (factory default setting). If the sensor is returned to factory defaults by using the remote input wire, the input wire remains enabled and the rest of the settings are restored to factory defaults.

Remote Teach

Use the following procedure to teach the Set Point.

1. Pulse the remote input:
 - * 3x - Object Teach: The indicator alternates between a blue Teach Status color and the Signal Level color.
 - * 4x - Background Teach: The indicator alternates between a magenta Teach Status color and the Signal Level color.
 - * 5x - Window Teach: The indicator alternates between a cyan Teach Status color and the Signal Level color.
2. Present the Set Point.
3. Teach the Set Point.

Action	Result
Single pulse the remote input.	<div style="text-align: center;">  </div> <p>Teach Accepted The indicator stops flashing and the device returns to operation.</p> <p>Teach Not Accepted The Signal Level color turns red during the teach procedure, and then the indicator stops flashing. Retry teaching the set point.</p>

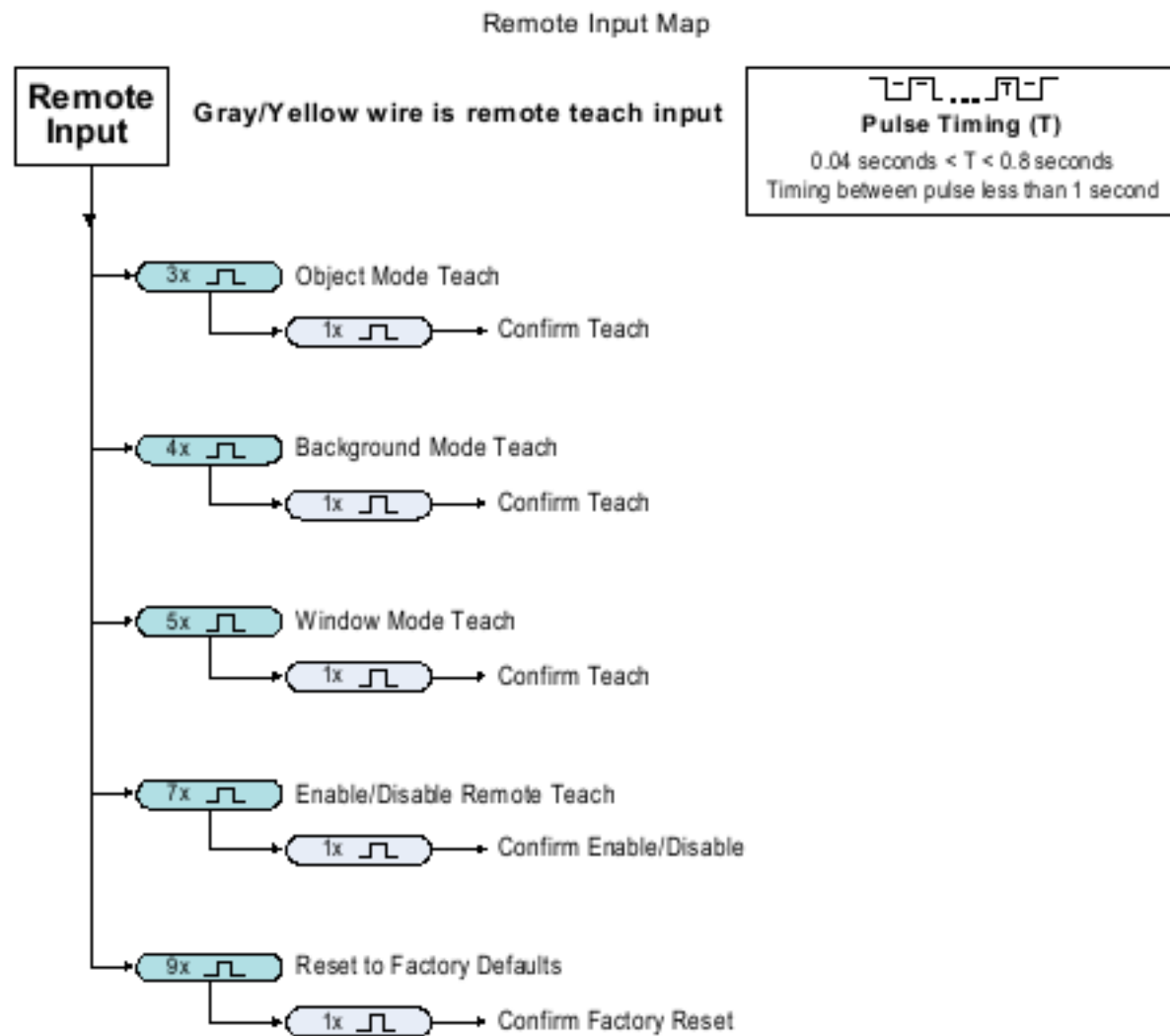

Teach Modes and Operation

Object Mode (default)
 Teach Status Color: Blue

The K50 Pro Select Optical Sensor is configured to Object Mode by default. Object Mode sets the total Detection Area from the sensor to the Set Point plus the Offset Value (50 mm default). Use Object Mode to trigger a change in state when an object is present between the sensor minimum (20 mm default) and the taught distance plus the offset.

Three-pulse the remote input to enable Object Mode. Successfully entering Object Mode causes the device to alternate between the Teach Status color (Blue) and the Signal Level color.

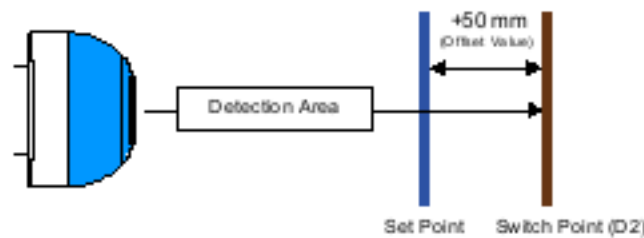

Background Mode
 Teach Status Color: Magenta

Background Mode sets the total Detection Area from the sensor to the Set Point minus the Offset Value (50 mm default). Use Background Mode when there is a constant background object present and a state change is desired when another object is in front of that background.

Four-pulse the remote input to enable Background Mode. Successfully entering Background Mode causes the device to alternate between the Teach Status color (Magenta) and the Signal Level color.



Window Mode
Teach Status Color: Cyan

Window Mode centers the total Detection Area at the Set Point plus and minus the Offset Value (50 mm default). Configuring a window near the minimum and maximum ranges shifts this window to ensure that it maintains this value. Use Window Mode when a change in state is desired within a specific narrow area, and not when outside this area.

Five-pulse the remote input to enable Window Mode. Successfully entering Window Mode causes the device to alternate between the Teach Status color (Cyan) and the Signal Level color.

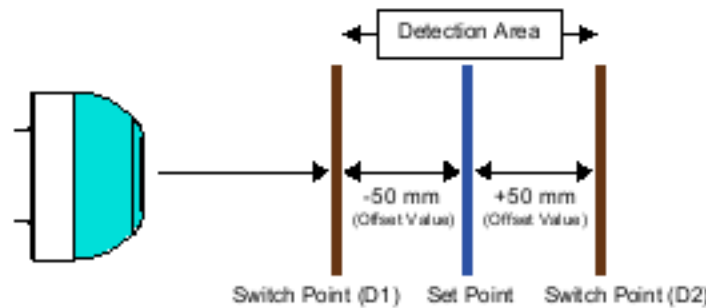

Reset the Sensor to Factory Defaults

Reset the sensor to factory default settings using one of two methods.

NOTE: If a factory reset is performed through the Banner Pro Editor software, the remote input wire becomes disabled (factory default setting). If the sensor is returned to factory default settings by using the remote input wire, the input wire remains enabled and the rest of the settings are restored to factory defaults.

Reset Using the Banner Pro Editor Software

Go to Sensor > Factory Reset. The sensor indicators flash once, the sensor is reset back to the factory default settings, and a confirmation message displays.

Reset Using the Remote Input

Nine-pulse the remote input to reset the device to factory default settings. The device then flashes white on success.

Pulse the remote input once more to apply the factory defaults.

Factory Default Settings via Remote Teach Mode

Default Settings

Setting	Factory Default
Discrete Output and Remote Input	Bimodal
Remote Input Wire	Enabled
Offset	50 mm (2 in)
Operation Mode	Object Mode
D1	20 mm (0.8 in)

Continued on page 10

Continued from page 9

Setting	Factory Default
D2	1000 mm (39.4 in)
NO/NC	Normally open
On Delay	0 ms
Off Delay	0 ms

Chapter Contents

Detection 11
 Distance 11
 Coarse Distance 12
 Advanced Settings 12

Chapter 4 Alternate Modes through Pro Editor

Set sensor parameters for the following applications:

- Detection
- Distance
- Coarse Distance

Detection

Detect materials or objects using an adjustable field up to a specific distance, ignoring objects beyond this distance (background suppression), or within a windowed range.

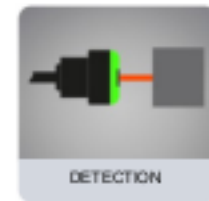

Detection settings

Device Logic Mode: Output Switchpoint Low(mm): Output Switchpoint High(mm):

Preview	Device State	Animation	Color 1		Color 2		Speed	Pattern	Direction
			Color	Intensity	Color	Intensity			
<input type="button" value="Start"/>	Power	<input type="text" value="OFF"/>							
<input type="button" value="Start"/>	WH	<input type="text" value="Steady"/>	<input type="text" value="Green"/>	<input type="text" value="Hi"/>					
<input type="button" value="Start"/>	GY	<input type="text" value="Steady"/>	<input type="text" value="Red"/>	<input type="text" value="Hi"/>					
<input type="button" value="Start"/>	WH & GY	<input type="text" value="Steady"/>	<input type="text" value="Yellow"/>	<input type="text" value="Hi"/>					

Distance

Set the device to operate as a gauge, which allows the user to configure a background color and a fill color to display how far an object is within the Detection Area.

As an object moves along the sensing range, the proportion of fill color to background color changes in a clockwise (CW) or counter-clockwise (CCW) direction. The proportion of fill color increases as an object approaches the maximum range, and decreases as it moves towards the minimum.



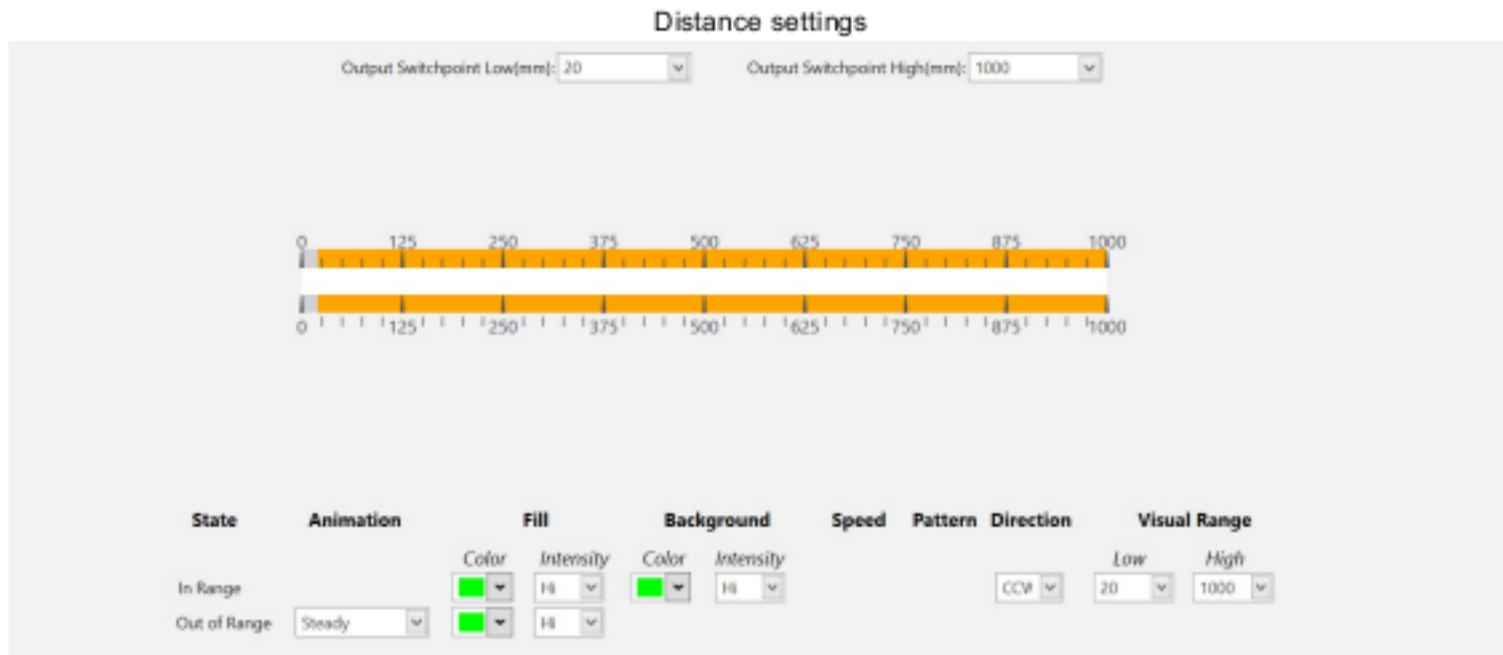

Coarse Distance

Divide the Detection Area into custom zones to generate a unique animation when an object is present within that zone distance.

Configure up to six zones for animation and output state. The minimum zone distance is 50 mm.

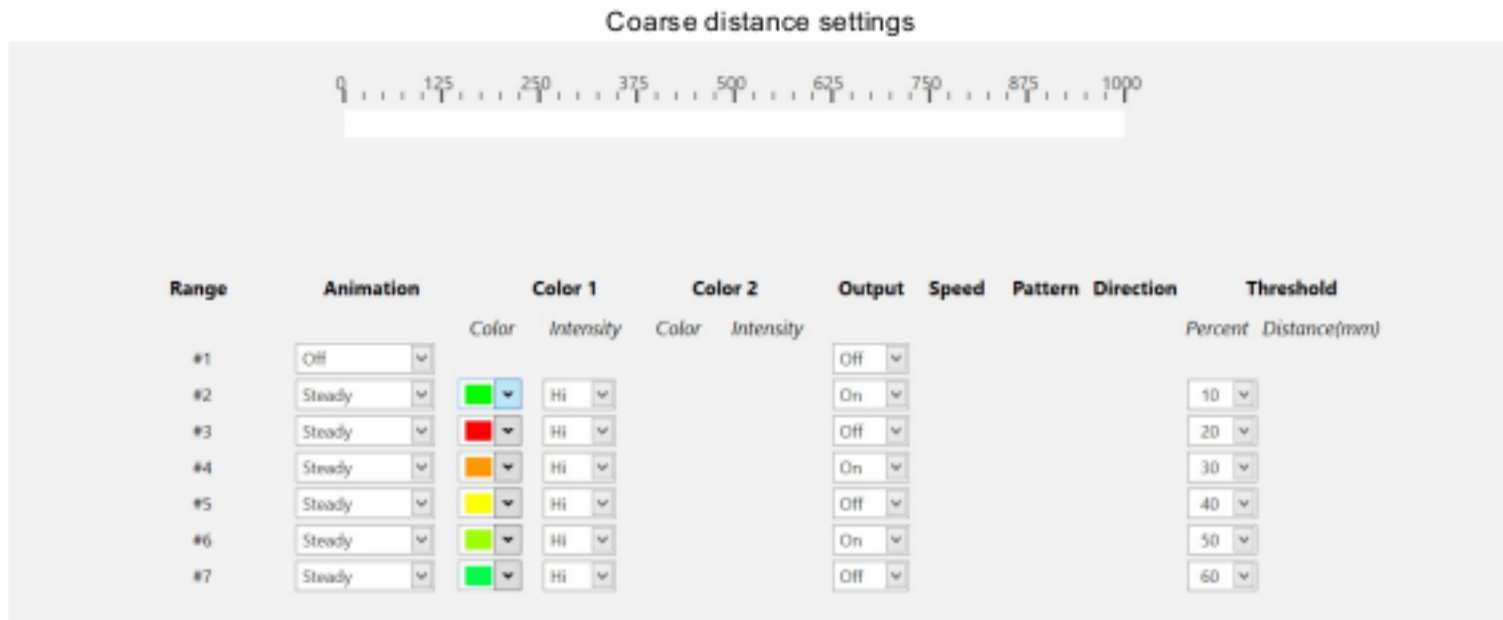

Advanced Settings

When a sensor device is connected, the following Advanced Settings can be accessed by clicking on the AdvancedSettings menu.

Optical AF Sensor Advanced Settings – Pro Editor

Advanced Settings

Output "On" Delay (ms):

Output "Off" Delay (ms):

Output Type: Momentary Latching

Output is Normally: Open Closed

Confirm

Chapter Contents

FCC Part 15 Class B for Unintentional Radiators 15
 Industry Canada ICES-003(B) 15
 Dimensions 16
 Beam Pattern 16

Chapter 5 Specifications

Supply Voltage and Current
 10 V DC to 30 V DC

- 220 mA at 10 V DC (exclusive of load)
- 190 mA at 12 V DC (exclusive of load)
- 115 mA at 24 V DC (exclusive of load)
- 100 mA at 30 V DC (exclusive of load)

Supply Protection Circuitry
 Protected against transient voltages and output short-circuit

Leakage Current Immunity
 400 µA

Vibration and Mechanical Shock
 Meets IEC 60068-2-6 requirements (Vibration: 10 Hz to 55 Hz, 1.0 mm amplitude, 5 minutes sweep, 30 minutes dwell)
 Meets IEC 60068-2-27 requirements (Shock: 30G 11 ms duration, half sine wave)

Operating Conditions
 -20 °C to +50 °C (-4 °F to +122 °F)
 90% at +50 °C maximum relative humidity (non-condensing)
 Storage Temperature: -40 °C to +70 °C (-40 °F to +158 °F)

Environmental Rating
 IP66, IP67, IP69K per ISO 20653

Connections
 Integral 5-pin M12 male quick-disconnect connector

Mounting
 M30 by 1.5 threaded base, maximum torque 4.5 N·m (40 inch-lbf)
 Mounting nut included

Construction
 Base and Dome: Polycarbonate
 Mounting Nut: Polybutylene terephthalate (PBT)

Application Note
 For the most accurate measurements, allow 5 minutes for the sensor to warm up

Remote Input
 Allowable Input Voltage Range: 0 to V_{supply}
 Active High (internal weak pull-down): High state > (V_{supply} - 2.25 V) at 2 mA maximum
 Active Low (internal weak pull-up): Low state < 2.25 V at 2 mA maximum

Repeatability
 5 mm from 20 to 300 mm
 8 mm from 300 mm to 600 mm
 14 mm from 600 mm to 1000 mm

Temperature Effect
 <±5 mm from -20 °C to +50 °C (-4 °F to +122 °F)

Required Overcurrent Protection



WARNING: Electrical connections must be made by qualified personnel in accordance with local and national electrical codes and regulations.

Overcurrent protection is required to be provided by end product application per the supplied table.

Overcurrent protection may be provided with external fusing or via Current Limiting, Class 2 Power Supply.

Supply wiring leads < 24 AWG shall not be spliced.

For additional product support, go to www.bannerengineering.com.

Supply Wiring (AWG)	Required Overcurrent Protection (A)	Supply Wiring (AWG)	Required Overcurrent Protection (A)
20	5.0	26	1.0
22	3.0	28	0.8
24	1.0	30	0.5

Certifications



Banner Engineering BV
 Park Lane, Culliganlaan 2F bus 3
 1831 Diegem, BELGIUM



Output Ratings

- Maximum Load: 150 mA
- ON-State Saturation Voltage:
 - < 2 V DC at 10 mA
 - < 2.5 V DC at 150 mA
- OFF-State Leakage Current: < 10 µA at 30 V DC

Output Response Time

- Power-Up Delay: < 1 s
- Input Response: 40 milliseconds maximum
- Switching Frequency: 4 Hz
- Discrete Output Response: 120 ms

Range

The sensor can detect an object at the following ranges, depending on the material and size of the target: 20 mm to 1000 mm

Sensing Beam

Infrared, 940 nm

Default Indicator Characteristics

Color	Dominant Wavelength (nm) or Color Temperature (CCT)	Color Coordinates ⁽²⁾		Lumen Output Per Segment (Typical at 25 °C)
		X	Y	
Green	522	0.154	0.7	19.5
Red	620	0.689	0.309	10.3
Yellow	576	0.477	0.493	25.8
Blue	466	0.14	0.054	3.6
White	5700K	0.328	0.337	30.5
Cyan	493	0.17	0.34	22.1
Magenta	-	0.379	0.172	12.7
Amber	589	0.556	0.42	17.9
Rose	-	0.525	0.237	10.6
Lime Green	562	0.383	0.523	25.3
Sky Blue	486	0.145	0.24	17.8
Orange	599	0.616	0.37	14.3
Violet	-	0.224	0.099	14.3
Spring Green	508	0.155	0.524	20

FCC Part 15 Class B for Unintentional Radiators

(Part 15.105(b)) This equipment has been tested and found to comply with the limits for a Class B digital device, pursuant to part 15 of the FCC Rules. These limits are designed to provide reasonable protection against harmful interference in a residential installation. This equipment generates, uses, and can radiate radio frequency energy and, if not installed and used in accordance with the instructions, may cause harmful interference to radio communications. However, there is no guarantee that interference will not occur in a particular installation. If this equipment does cause harmful interference to radio or television reception, which can be determined by turning the equipment off and on, the user is encouraged to try to correct the interference by one or more of the following measures:

- Reorient or relocate the receiving antenna.
- Increase the separation between the equipment and receiver.
- Connect the equipment into an outlet on a circuit different from that to which the receiver is connected.
- Consult the dealer or an experienced radio/TV technician for help.

(Part 15.21) Any changes or modifications not expressly approved by the party responsible for compliance could void the user's authority to operate this equipment.

Industry Canada ICES-003(B)

This device complies with CAN ICES-3 (B)/NMB-3(B). Operation is subject to the following two conditions: 1) This device may not cause harmful interference; and 2) This device must accept any interference received, including interference that may cause undesired operation.

Cet appareil est conforme à la norme NMB-3(B). Le fonctionnement est soumis aux deux conditions suivantes : (1) ce dispositif ne peut pas occasionner d'interférences, et (2) il doit tolérer toute interférence, y compris celles susceptibles de provoquer un fonctionnement non souhaité du dispositif.

⁽²⁾ Refer to CIE 1931 chromaticity diagram or color chart to show equivalent color with indicated color coordinates. Actual coordinates may differ by 10%.

Dimensions

All measurements are listed in millimeters [inches], unless noted otherwise. The measurements provided are subject to change.

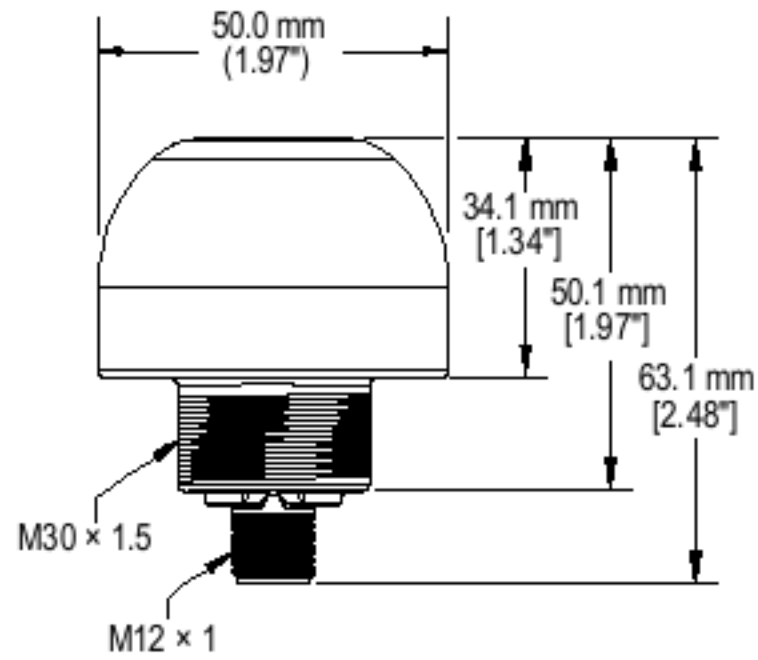

Beam Pattern

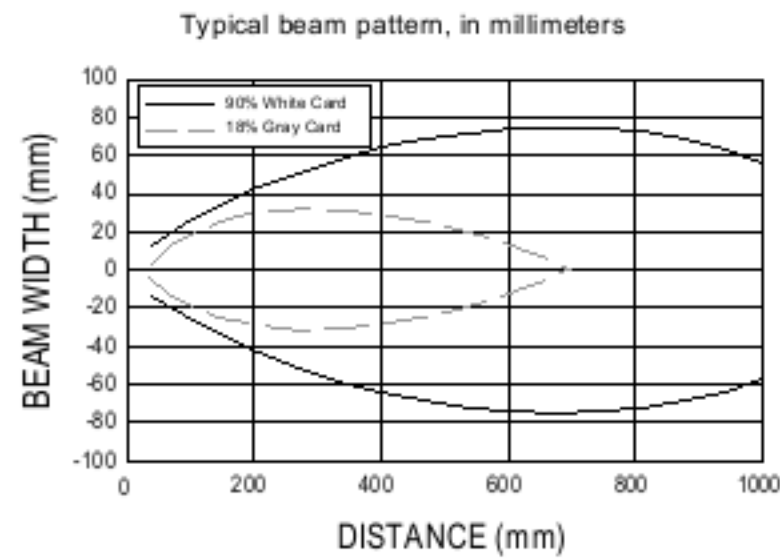





Chapter Contents

Pro Editor Hardware 17
 Cordsets 18
 Brackets 18
 Elevated Mount System 20

Chapter 6 Accessories

Pro Editor Hardware

<p>MQDC-506-USB</p> <ul style="list-style-type: none"> • Pro Converter Cable • 1.83 m (6 ft) length 5-pin M12 quick disconnect to Device and USB to PC • Required for connection to the configuration software 	
<p>CSB-M1251FM1251M</p> <ul style="list-style-type: none"> • 5-pin parallel Y splitter (Male-Male-Female) • For full Pro Editor preview capability • Requires external power supply, sold separately 	
<p>PSW-24-1</p> <ul style="list-style-type: none"> • 24 V DC, 1 A power supply • 2 m (6.5 ft) PVC cable with M12 quick disconnect • Provides external power with splitter cable, sold separately 	
<p>PSW-24-2</p> <ul style="list-style-type: none"> • 24 V DC, 2 A power supply • 3.5 m (11.5 ft) PVC cable with M12 quick disconnect • Provides external power with splitter cable, sold separately 	

Cordsets

All measurements are listed in millimeters [inches], unless noted otherwise. The measurements provided are subject to change.

5-pin Double-Ended M12 Female to M12 Male Cordsets				
Model	Length	Dimensions (mm)	Pinouts	
BC-M12F5-M12M5-22-0.16M	0.16 m (0.52 ft)		Female	1 = Brown 2 = White 3 = Blue 4 = Black 5 = Gray
BC-M12F5-M12M5-22-1	1 m (3.28 ft)			
BC-M12F5-M12M5-22-2	2 m (6.56 ft)			
BC-M12F5-M12M5-22-5	5 m (16.4 ft)			
BC-M12F5-M12M5-22-8	8 m (26.25 ft)			
BC-M12F5-M12M5-22-10	10 m (30.81 ft)			
BC-M12F5-M12M5-22-15	15 m (49.2 ft)			

5-pin Double-Ended M12 Female Right-Angle to M12 Male Right-Angle Cordsets				
Model	Length	Dimensions (mm)	Pinouts	
BC-M12F5A-M12M5A-22-1	1 m (3.28 ft)		Female	1 = Brown 2 = White 3 = Blue 4 = Black 5 = Gray
BC-M12F5A-M12M5A-22-2	2 m (6.56 ft)			
BC-M12F5A-M12M5A-22-5	5 m (16.4 ft)			
BC-M12F5A-M12M5A-22-8	8 m (26.25 ft)			
BC-M12F5A-M12M5A-22-10	10 m (30.81 ft)			
BC-M12F5A-M12M5A-22-15	15 m (49.2 ft)			

Brackets

<p>SMB30A</p> <ul style="list-style-type: none"> • Right-angle bracket with curved slot for versatile orientation • Clearance for M6 (1/4 in) hardware • Mounting hole for 30 mm sensor • 12-gauge stainless steel <p>Hole center spacing: A to B=40 Hole size: A=ø 6.3, B= 27.1 × 6.3, C=ø 30.5</p>	
--	--

<p>SMB30FVK</p> <ul style="list-style-type: none"> • V-clamp, flat bracket and fasteners for mounting to pipe or extensions • Clamp accommodates 28 mm dia. tubing or 1 in. square extrusions • 30 mm hole for mounting sensors <p>Hole size: A= ø 31</p>	
---	--

SMB30RAVK

- V-clamp, right-angle bracket and fasteners for mounting sensors to pipe or extrusion
- Clamp accommodates 28 mm dia. tubing or 1 in. square extrusions
- 30 mm hole for mounting sensors

Hole size: A = \varnothing 30.5

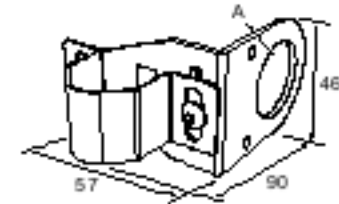

SMBAMS30P

- Flat SMBAMS series bracket
- 30 mm hole for mounting sensors
- Articulation slots for 90°+ rotation
- 12-gauge 300 series stainless steel

Hole center spacing: A=26.0, A to B=13.0
Hole size: A=26.8 × 7.0, B= \varnothing 6.5, C= \varnothing 31.0

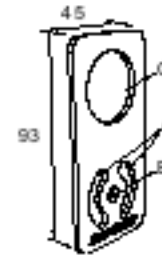

SMBAMS30RA

- Right-angle SMBAMS series bracket
- 30 mm hole for mounting sensors
- Articulation slots for 90°+ rotation
- 12-gauge (2.6 mm) cold-rolled steel

Hole center spacing: A=26.0, A to B=13.0
Hole size: A=26.8 × 7.0, B= \varnothing 6.5, C= \varnothing 31.0

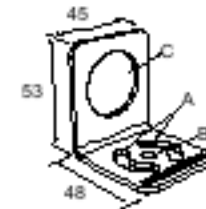

SMB30MM

- 12-gauge stainless steel bracket with curved mounting slots for versatile orientation
- Clearance for M6 (1/4 in) hardware
- Mounting hole for 30 mm sensor

Hole center spacing: A = 51, A to B = 25.4
Hole size: A = 42.6 × 7, B = \varnothing 6.4, C = \varnothing 30.1

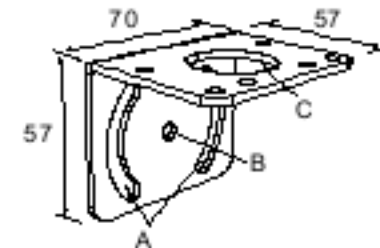

SMB30SC

- Swivel bracket with 30 mm mounting hole for sensor
- Black reinforced thermoplastic polyester
- Stainless steel mounting and swivel locking hardware included

Hole center spacing: A= \varnothing 50.8
Hole size: A= \varnothing 7.0, B= \varnothing 30.0

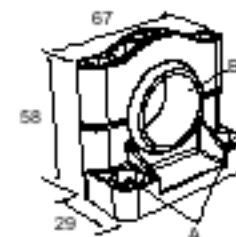

SMB30FA

- Swivel bracket with tilt and pan movement for precise adjustment
- Mounting hole for 30 mm sensor
- 12-gauge 304 stainless steel
- Easy sensor mounting to extrude rail T-slot
- Metric- and inch-size bolt available

Bolt thread: SMB30FA, A= 3/8 - 16 × 2 in; SMB30FAM10, A= M10 - 1.5 × 50
Hole size: B= \varnothing 30.1

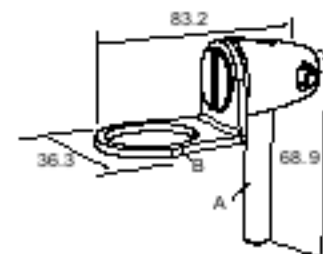

<p>LMBE12RA35</p> <ul style="list-style-type: none"> • Direct mounting of stand-off pipe, with common bracket type • Zinc-plated steel • 1/2-14 NPSM nut • Mounting distance from the wall to the center of the 1/2-14 NPSM nut is 35 mm <p>Hole center spacing: 20.0</p>	
--	--

<p>LMBE12RA45</p> <ul style="list-style-type: none"> • Direct mounting of stand-off pipe, with common bracket type • Zinc-plated steel • 1/2-14 NPSM nut • Mounting distance from the wall to the center of the 1/2-14 NPSM nut is 45 mm <p>Hole center spacing: 35.0</p>	
--	--

All measurements are listed in millimeters [inches], unless noted otherwise. The measurements provided are subject to change.

Elevated Mount System

Model		Description	Components
SA-M30E12P - Black Acetal		<ul style="list-style-type: none"> • Streamlined black acetal stand-off pipe adapter/cover • Connects between 30 mm light base and 1/2 in. NPSM/DN15 pipe • Mounting hardware included 	
Black Anodized Aluminum	Clear Anodized Aluminum	<ul style="list-style-type: none"> • Elevated-use stand-off pipe (1/2 in. NPSM/DN15) • Polished 304 stainless steel, black anodized aluminum, or clear anodized aluminum surface • 1/2 in. NPT thread at both ends: one end screws into the internal threads of the light's base, and one end screws into the mounting base adapter/cover • Compatible with most industrial environments 	
SOP-E12-150A	SOP-E12-150AC		
150 mm (6 in) long	150 mm (6 in) long		
SOP-E12-300A	SOP-E12-300AC		
300 mm (12 in) long	300 mm (12 in) long		
SOP-E12-600A	SOP-E12-600AC		
600 mm (24 in) long	600 mm (24 in) long		
SOP-E12-900A	SOP-E12-900AC		
900 mm (36 in) long	900 mm (36 in) long		

Chapter Contents

Clean with Mild Detergent and Water.....	21
Repairs	21
Contact Us.....	21
Banner Engineering Corp Limited Warranty	21

Chapter 7 Product Support and Maintenance

Clean with Mild Detergent and Water

Wipe down the enclosure and the display with a soft cloth that has been dampened with a mild detergent and warm water solution.

Repairs

Contact Banner Engineering for troubleshooting of this device. Do not attempt any repairs to this Banner device; it contains no field-replaceable parts or components. If the device, device part, or device component is determined to be defective by a Banner Applications Engineer, they will advise you of Banner’s RMA (Return Merchandise Authorization) procedure.

IMPORTANT: If instructed to return the device, pack it with care. Damage that occurs in return shipping is not covered by warranty.

Contact Us

Banner Engineering Corp. headquarters is located at: 9714 Tenth Avenue North | Plymouth, MN 55441, USA | Phone: + 1 888 373 6767

For worldwide locations and local representatives, visit www.bannerengineering.com.

Banner Engineering Corp Limited Warranty

Banner Engineering Corp. warrants its products to be free from defects in material and workmanship for one year following the date of shipment. Banner Engineering Corp. will repair or replace, free of charge, any product of its manufacture which, at the time it is returned to the factory, is found to have been defective during the warranty period. This warranty does not cover damage or liability for misuse, abuse, or the improper application or installation of the Banner product.

THIS LIMITED WARRANTY IS EXCLUSIVE AND IN LIEU OF ALL OTHER WARRANTIES WHETHER EXPRESS OR IMPLIED (INCLUDING, WITHOUT LIMITATION, ANY WARRANTY OF MERCHANTABILITY OR FITNESS FOR A PARTICULAR PURPOSE), AND WHETHER ARISING UNDER COURSE OF PERFORMANCE, COURSE OF DEALING OR TRADE USAGE.

This Warranty is exclusive and limited to repair or, at the discretion of Banner Engineering Corp., replacement. IN NO EVENT SHALL BANNER ENGINEERING CORP. BE LIABLE TO BUYER OR ANY OTHER PERSON OR ENTITY FOR ANY EXTRA COSTS, EXPENSES, LOSSES, LOSS OF PROFITS, OR ANY INCIDENTAL, CONSEQUENTIAL OR SPECIAL DAMAGES RESULTING FROM ANY PRODUCT DEFECT OR FROM THE USE OR INABILITY TO USE THE PRODUCT, WHETHER ARISING IN CONTRACT OR WARRANTY, STATUTE, TORT, STRICT LIABILITY, NEGLIGENCE, OR OTHERWISE.

Banner Engineering Corp. reserves the right to change, modify or improve the design of the product without assuming any obligations or liabilities relating to any product previously manufactured by Banner Engineering Corp. Any misuse, abuse, or improper application or installation of this product or use of the product for personal protection applications when the product is identified as not intended for such purposes will void the product warranty. Any modifications to this product without prior express approval by Banner Engineering Corp will void the product warranties. All specifications published in this document are subject to change; Banner reserves the right to modify product specifications or update documentation at any time. Specifications and product information in English supersede that which is provided in any other language. For the most recent version of any documentation, refer to: www.bannerengineering.com.

For patent information, see www.bannerengineering.com/patents.

