

Features

- Advanced one-piece photoelectric sensors with outstanding optical performance and extremely rugged design
- Universal supply voltage: 12 to 250 V DC or 24 to 250 V AC
- Electromechanical relay for economical, high-capacity switching and immunity to electrical noise
- Multiple sensing modes available: opposed, diffuse, retroreflective, and convergent, plus glass and plastic fiber optic models
- Selectable light/dark operate
- Versatile plug-in modules available for output timing logic and/or signal strength display
- Highly visible Power, Signal (AID™ System ⁽¹⁾), and Output indicator LEDs
- Choice of prewired 2 m (6.5 ft) or 9 m (30 ft) unterminated cable or 7/8 in-16UNF quick-disconnect fitting
- Versatile mounting options
- Designed to withstand 1200 psi washdown; exceeds its NEMA 6P and IEC IP67 rating



WARNING:



- Do not use this device for personnel protection
- Using this device for personnel protection could result in serious injury or death.
- This device does not include the self-checking redundant circuitry necessary to allow its use in personnel safety applications. A device failure or malfunction can cause either an energized (on) or de-energized (off) output condition.

Models

To order the 9 m (30 ft) cable models, add the suffix "W/30" to the cabled model number. For example: Q453E W/30.

Models with a quick disconnect connector require a mating cable.

Q45VR3 Opposed-Mode Emitter (E) and Receiver (R) Models

In opposed-mode sensing, the sensor's emitter and receiver are housed in two separate units. The emitter is placed opposite the receiver so that the light beam goes directly from the emitter to the receiver. An object is detected when it breaks the working part of the light beam, known as the effective beam.

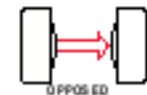

Because of their extremely high excess gain, these opposed-mode sensors are an excellent option for sensing in contaminated or dirty areas and are also the best choice for long-range sensing.

Infrared, 880 nm

Models	Cable	Range	Supply Voltage	Output Type
Q453E Emitter	2-wire 2 m (6.5 ft) cable	60 m (200 ft)	Universal 12 to 250 V DC or 24 to 250 V AC	SPDT Electro-mechanical relay
Q45VR3R Receiver	5-wire 2 m (6.5 ft) cable			
Q453EQ Emitter	3 g-n 7/8 in 18UNF Q0			
Q45VR3RQ Receiver	5 g-n 7/8 in 18UNF Q0			

Q45VR3 Retroreflective-Mode Models

A retroreflective sensor contains both the emitter and receiver elements. The effective beam is established between the emitter, the retroreflector, and the receiver. As with an opposed-mode sensor, an object is sensed when it interrupts or "breaks" the effective beam.

The visible red sensing beam of these sensors makes them very easy to align. Model Q45VR3LP polarizes the emitted light and filters out unwanted reflections, making sensing possible in applications otherwise considered unsuited to retroreflective sensing.

Specified using the model BRT-3 3-inch reflector (go to www.bannerengineering.com for additional information).



Visible red, 680 nm (non-polarized)



Visible red, 680 nm (polarized)

⁽¹⁾ U.S. Patent no. 4356393



Non-Polarized				
Models	Range	Cable	Supply Voltage	Output Type
Q45VR3LV	0.08 to 9 m (3 in to 30 ft)	5-wire 2 m (6.5 ft) cable	Universal 12 to 250 V DC or 24 to 250 V AC	SPDT Electro-mechanical relay
Q45VR3LVQ		5-pin 7/8 in-16UNF QD		
Polarized				
Models	Range	Cable	Supply Voltage	Output Type
Q45VR3LP	0.15 to 6 m (6 in to 20 ft)	5-wire 2 m (6.5 ft) cable	Universal 12 to 250 V DC or 24 to 250 V AC	SPDT Electro-mechanical relay
Q45VR3LPQ		5-pin 7/8 in-16UNF QD		

Q45VR3 Diffuse-Mode Models

In diffuse-mode sensing, light emitted from the sensor strikes the surface of the object to be detected and is diffused back in a relatively narrow beam, sending some light back to the receiver, which is usually housed with the emitter. With a diffuse-mode sensor, the object is detected when it "makes" the beam, that is, the object reflects the sensor's transmitted light energy back to the sensor.

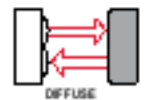

These diffuse-mode models detect objects by sensing the reflection of their own emitted light, making them ideal when the reflectivity and profile of the object to be sensed are sufficient to return a large percentage of emitted light back to the sensor.

Model Q45VR3DX is the first choice for diffuse-mode applications when there are no background objects to falsely return light.

Infrared, 880 nm

Short Range				
Models	Range	Cable	Supply Voltage	Output Type
Q45VR3D	45 cm (18 inches)	5-wire 2 m (6.5 ft) cable	Universal 12 to 250 V DC or 24 to 250 V AC	SPDT Electro-mechanical relay
Q45VR3DQ		5-pin 7/8 in-16UNF QD		
Long Range				
Models	Range	Cable	Supply Voltage	Output Type
Q45VR3DL	1.8 m (6 ft)	5-wire 2 m (6.5 ft) cable	Universal 12 to 250 V DC or 24 to 250 V AC	SPDT Electro-mechanical relay
Q45VR3DLQ		5-pin 7/8 in-16UNF QD		
High Power				
Models	Range	Cable	Supply Voltage	Output Type
Q45VR3DX	3 m (10 ft)	5-wire 2 m (6.5 ft) cable	Universal 12 to 250 V DC or 24 to 250 V AC	SPDT Electro-mechanical relay
Q45VR3DXQ		5-pin 7/8 in-16UNF QD		

Q45VR3 Convergent-Mode Models

Convergent-mode sensors use a lens system to focus the emitter and receiver elements to an exact point in front of the sensor. Like diffuse-mode and divergent-mode sensors, convergent-mode sensors detect an object when that object completes or "makes" the light beam. This design produces a small, intense, and well-defined sensing area, at a fixed distance from the sensor lens. It is a very efficient use of reflective energy.



These sensors are ideal for reflective sensing of very small parts or profiles and can accurately sense the position of parts approaching from the side. The sensor ignores all but highly reflective objects that are outside the sensing range.

Visible red, 680 nm

Models	Focus	Cable	Supply Voltage	Output Type
Q45VR3CV	38 mm (1.5 in) Spot Size at Focus: 1.3 mm (0.05 in)	5-wire 2 m (6.5 ft) cable	Universal 12 to 250 V DC or 24 to 250 V AC	SPDT Electro-mechanical relay
Q45VR3CVQ		5-pin 7/8 in-16UNF QD		
Q45VR3CV4	100 mm (4 in) Spot Size at Focus: 1.5 mm (0.06 in)	5-wire 2 m (6.5 ft) cable	Universal 12 to 250 V DC or 24 to 250 V AC	SPDT Electro-mechanical relay
Q45VR3CV4Q		5-pin 7/8 in-16UNF QD		

Q45VR3 Glass Fiber Optic Models

These models are an excellent choice for glass fiber optic applications where faster sensor response is not important. Their high excess gain means that opposed individual fibers can operate reliably in many very hostile environments. Also, special miniature bifurcated fiber optic assemblies with bundle sizes as small as 0.5 mm (.020 in) diameter may be used successfully for diffuse-mode sensing when using sensor model Q45VR3F(Q). For more information on compatible glass fiber optics, go to www.bannerengineering.com.

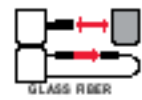

Infrared, 880 nm and Visible red, 650 nm

Infrared, 880 nm				
Models	Range	Cable	Supply Voltage	Output Type
Q45VR3F	Range varies by sensing mode and fiber optics used.	5-wire 2 m (6.5 ft) cable	Universal 12 to 250 V DC or 24 to 250 V AC	SPDT Electro-mechanical relay
Q45VR3FQ		5-pin 7/8 in 16UNF QD		
Visible Red, 650 nm				
Models	Range	Cable	Supply Voltage	Output Type
Q45VR3FV	Range varies by sensing mode and fiber optics used.	5-wire 2 m (6.5 ft) cable	Universal 12 to 250 V DC or 24 to 250 V AC	SPDT Electro-mechanical relay
Q45VR3FVQ		5-pin 7/8 in 16UNF QD		

Q45VR3 Plastic Fiber Optic Models

Lower in cost than glass fiber optics, plastic fiber optics are ideal for use in situations where environmental conditions allow (for example, low levels of acids, alkalis, and solvents). Most are easily cut to length in the field, and are available in a variety of sensing end styles. For more information on compatible plastic fiber optics, go to www.bannerengineering.com.

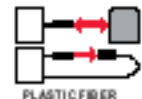

Visible red, 660 nm

Models	Range	Cable	Supply Voltage	Output Type
Q45VR3FP	Range varies by sensing mode and fiber optics used.	5-wire 2 m (6.5 ft) cable	Universal 12 to 250 V DC or 24 to 250 V AC	SPDT Electro-mechanical relay
Q45VR3FPQ		5-pin 7/8 in 16UNF QD		

Overview

Status indicator LEDs for power, signal, and output are clearly visible beneath a raised dome in the sensor's transparent o-ring-sealed polycarbonate cover. Also located beneath the sensor's o-ring-sealed cover are controls for light/dark operate selection and the sensitivity adjustment.

- The power indicator (green) lights when power is applied to the sensor.
- The signal indicator (red) lights when the sensor sees its modulated light source and pulses at a rate proportional to the strength of the received light signal; this is the AID™ Alignment Indicating Device⁽¹⁾.
- The output indicator (amber) lights when the sensor's output is conducting. This indicator is especially useful when a timing logic module is used and signal and output conditions are not concurrent.

In dark operate (DO) mode, the output is ON when the target returns less light to the sensor than the configured target and OFF when the sensor detects more light than the configured/taught target. In light operate (LO) mode, the output is ON when the target returns the same or more light to the sensor and OFF when the sensor detects less light than the configured/taught target. In opposed and retroreflective sensing modes, dark operate is active when the beam is blocked. In diffuse, fixed field, and adjustable field sensor modes, dark operate is active when the target is absent.

In light operate (LO) mode, the output is ON when the target returns the same or more light to the sensor and OFF when the sensor detects less light than the configured/taught target. In opposed and retroreflective sensing modes, light operate is active when the beam is unblocked. In diffuse, fixed field, and adjustable field sensor modes, light operate is active when the target is present.

1. Sensitivity adjustment
2. LEDs
 - * Green LED: Power on indicator
 - * Red LED: Signal indicator
 - * Amber LED: Output status indicator
3. Optional LED signal strength display
4. Optional timing adjustment
5. Optional timing adjustment
6. Light/dark operate switch



⁽¹⁾ US patent no. 4356393

Wiring Diagrams

Q45VR3 Sensors with Attached Cable

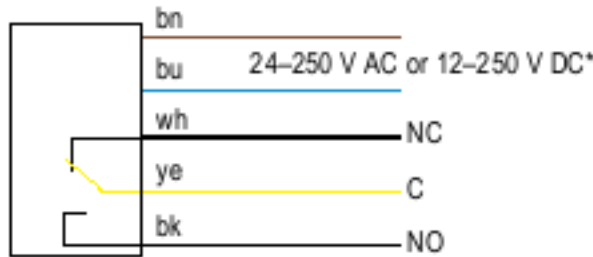

Q45VR3 Sensors with Quick-Disconnect 5-Pin 7/8 in-16UNF (model suffix Q)

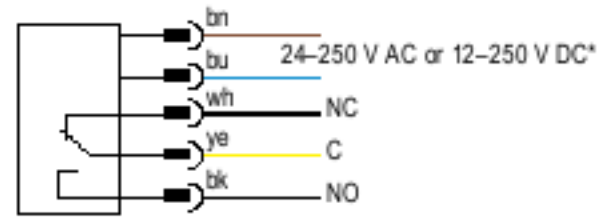

Q453E Emitters with Attached Cable

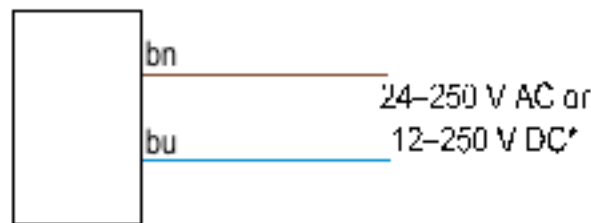

Q453EQ Emitters with Quick-Disconnect 3-Pin 7/8 in-16UNF

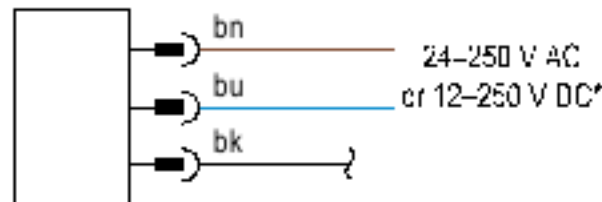

*Connection of DC power is without regard to polarity.

Specifications

Supply Voltage and Current

Universal voltage: 24 to 250 V AC, 50/60 Hz or 12 to 250 V DC (1.5 watts maximum)

Supply Protection Circuitry

Protected against transient voltages
DC connection is without regard to polarity.

Output Configuration

SPDT (Single-Pole, Double-Throw) electromechanical relay output. All models except emitters.

Output Rating

Max. switching power (resistive load): 1250 VA, 150 W
Max. switching voltage (resistive load): 250 V AC, 125 V DC
Max. switching current (resistive load): 5 A @ 250 V AC, 5A @ 30 V DC derated to 200 mA @ 125 V DC
Min. voltage and current: 5 V DC, 10 mA
Mechanical life of relay: 50,000,000 operations
Electrical life of relay at full resistive load: 100,000 operations

Output Protection Circuitry

Protected against false pulse on power-up

Output Response Time

15 milliseconds ON and OFF

NOTE: 100 millisecond delay on power-up. Relay is de-energized during this time.

Repeatability

Opposed mode: 0.25 milliseconds
All other sensing modes: 0.5 milliseconds
Response time and repeatability specifications are independent of signal strength

Adjustments

Light/Dark Operate select switch; and multi-turn Sensitivity control on top of sensor beneath a transparent o-ring-sealed cover, allows precise sensitivity setting (turn clockwise to increase gain). Optional logic and logic/display modules have adjustable timing functions.

Indicators

Indicator LEDs are clearly visible beneath a raised transparent Lexan® dome on top of the sensor.

Power (green) LED lights whenever 24 to 250 V ac, or 12 to 250 V dc power is applied

Signal (red) AID™ System LED lights whenever the sensor sees its modulated light source, and pulses at a rate proportional to the strength of the received light signal

Load (amber) LED lights whenever the output relay is energized

Optional 7-element LED signal strength display module

Construction

Molded reinforced thermoplastic polyester housing, o-ring-sealed transparent Lexan®⁽¹⁾ cover, molded acrylic lenses, and stainless steel hardware. Q45s are designed to withstand 1200 psi washdown. The base of cabled models has a 1/2-inch NPS integral internal conduit thread.

Connections

PVC-jacketed 2 m (6.5 ft) or 9 m (30 ft) unterminated cables, or Mini-style quick-disconnect (QD) fittings are available ("Q"-suffix models). QD cables are ordered separately.

Application Notes

Transient suppression is recommended for contacts switching inductive loads. Optional output timing modules are available. See "Output Timing Logic and Signal Strength Display Modules" on page 9 for more information.

Environmental Rating

NEMA 6P, IP67

Operating Conditions

Temperature: -25 °C to +55 °C (-13 °F to +131 °F)
90% at +50 °C maximum relative humidity (non-condensing)

Certifications

CE Banner Engineering BV
Park Lane, Culliganlaan 2F bus 3
1831 Diegem, BELGIUM

UL US

⁽¹⁾ Lexan® is a registered trademark of General Electric Co.

Required Overcurrent Protection



WARNING: Electrical connections must be made by qualified personnel in accordance with local and national electrical codes and regulations.

Overcurrent protection is required to be provided by end product application per the supplied table.
Overcurrent protection may be provided with external fusing or via Current Limiting, Class 2 Power Supply.

Supply wiring leads < 24 AWG shall not be spliced.

For additional product support, go to www.bannerengineering.com.

Supply Wiring (AWG)	Required Overcurrent Protection (A)	Supply Wiring (AWG)	Required Overcurrent Protection (A)
20	5.0	28	1.0
22	3.0	28	0.8
24	1.0	30	0.5

Dimensions

Opposed, Retro, and Diffuse Sensing Modes (Model Suffix E, R, D, DL, DX, LP, and LV)

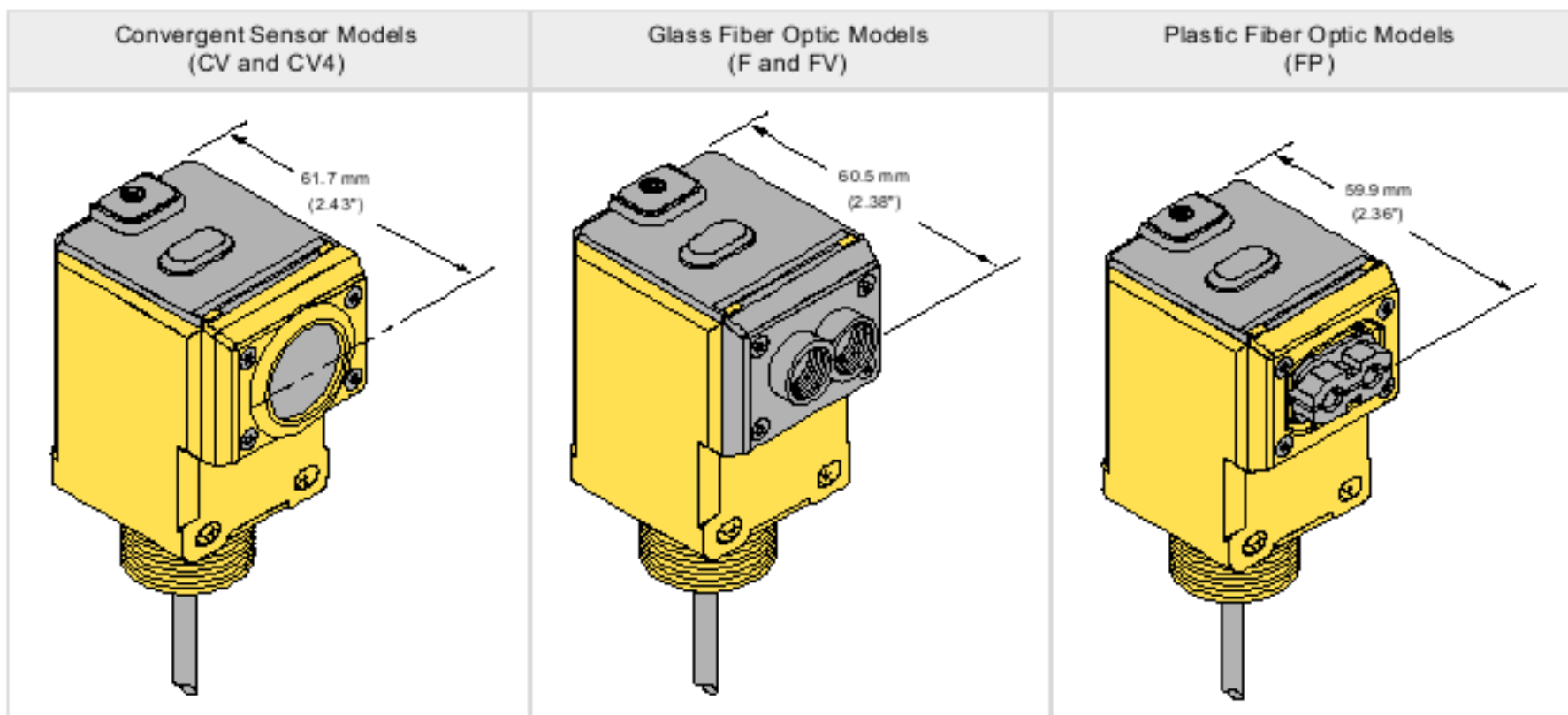
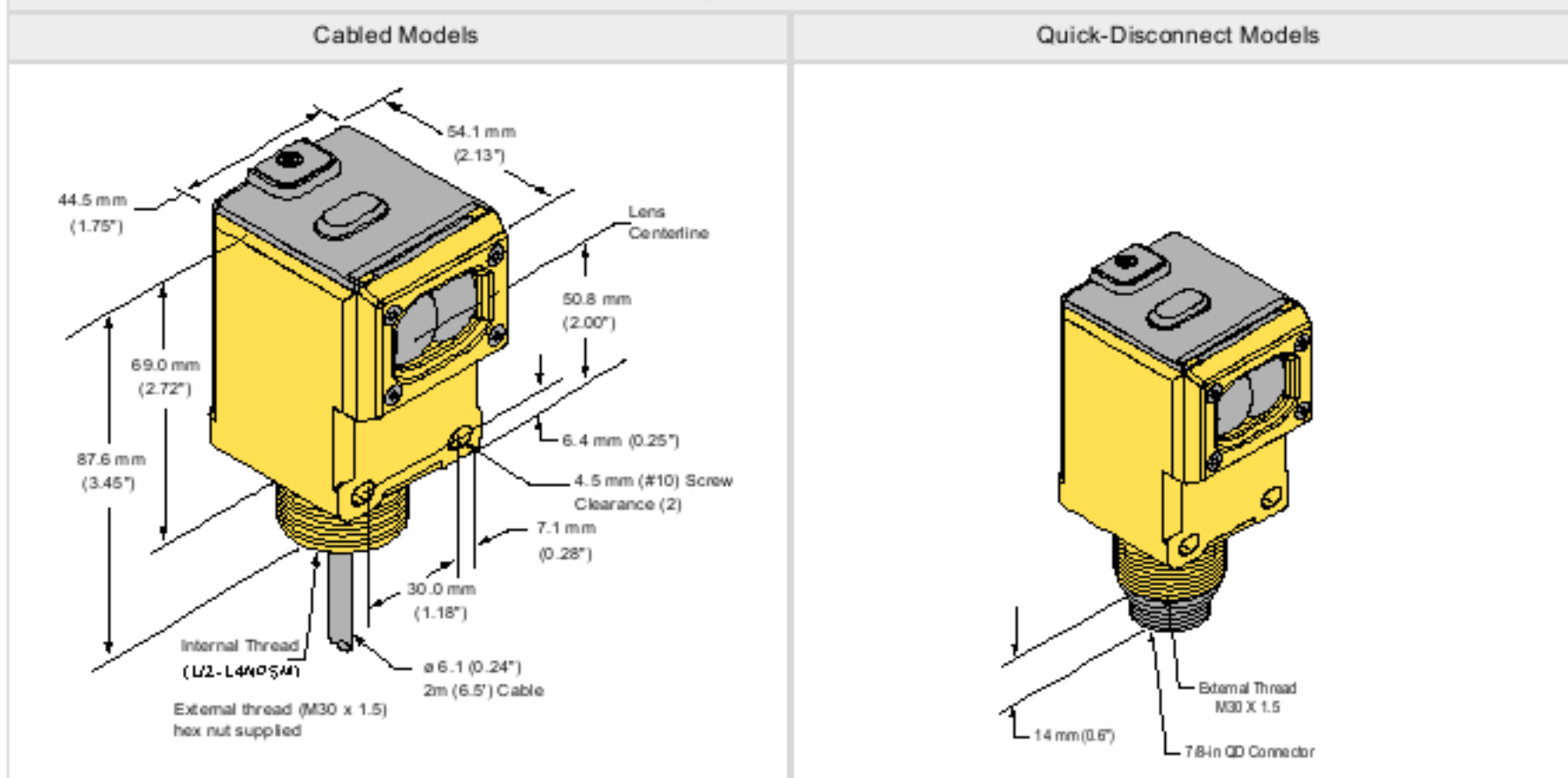

Performance Curves

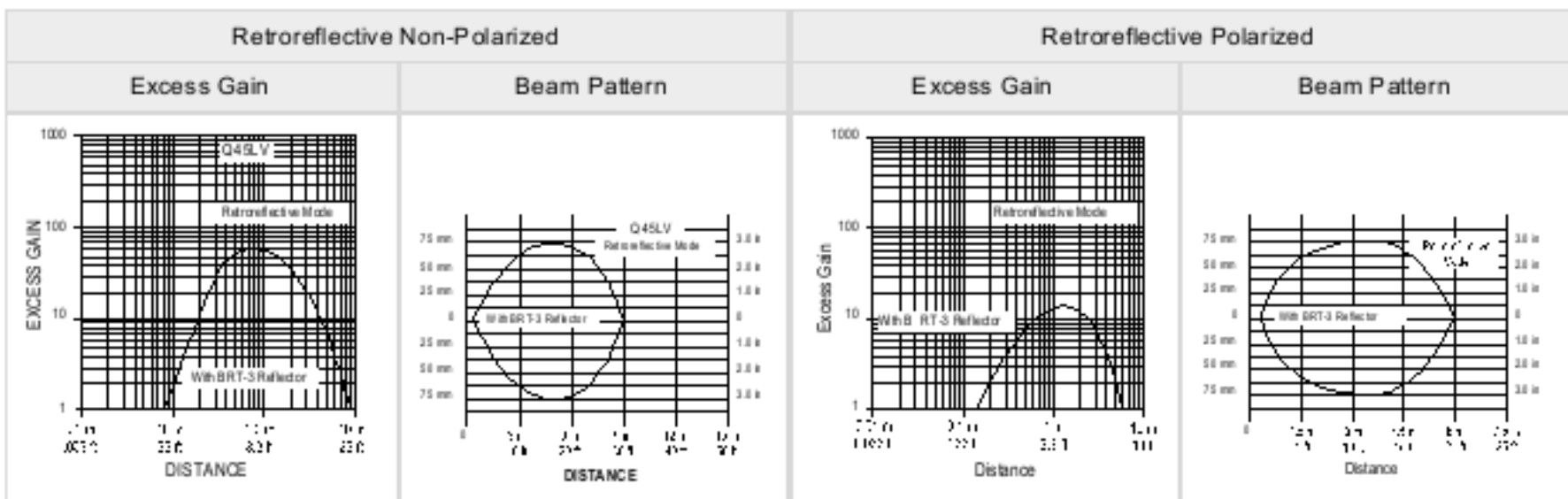
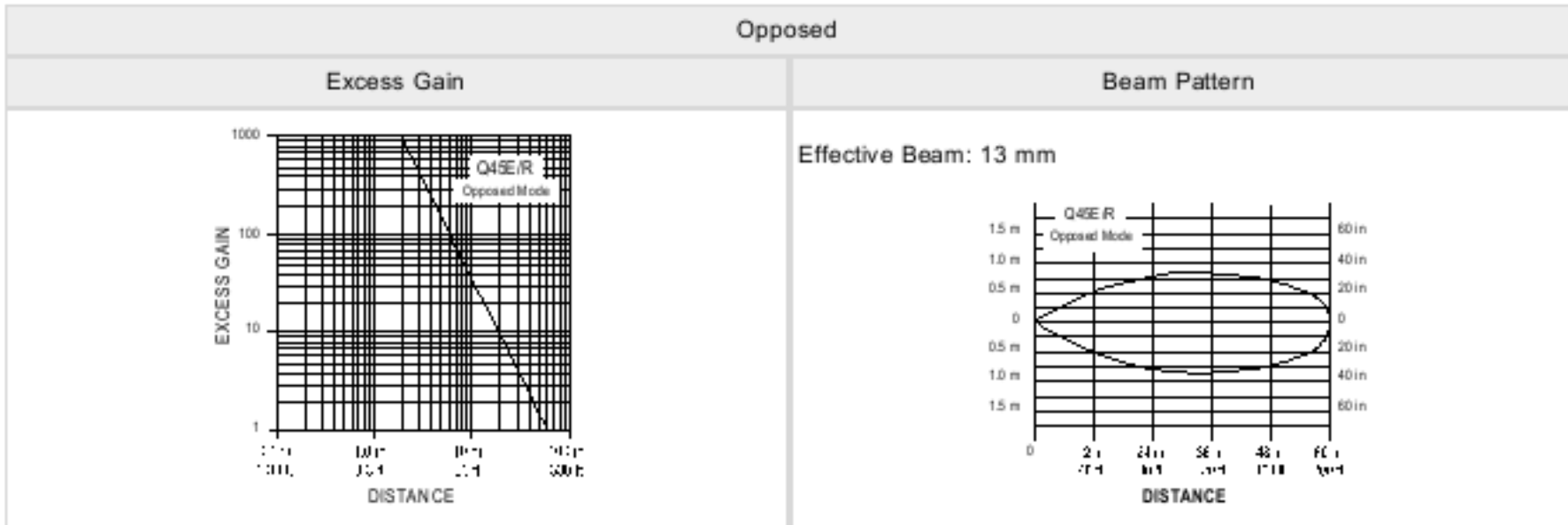

Diffuse-mode performance curves are based on a 90% reflectance white test card.

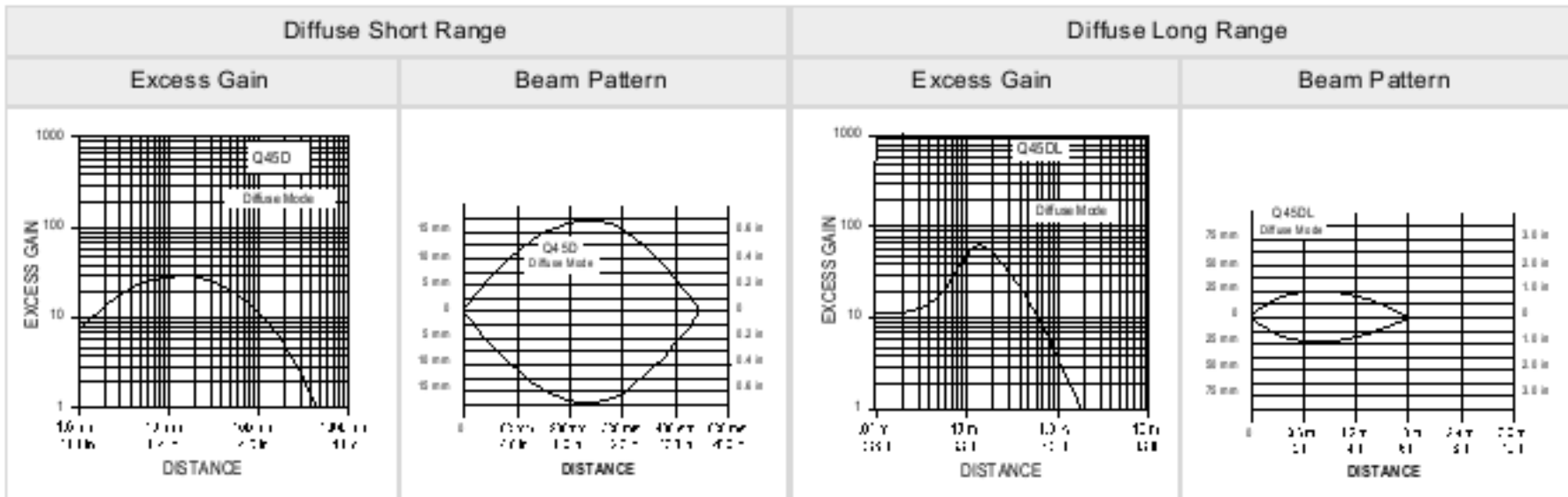

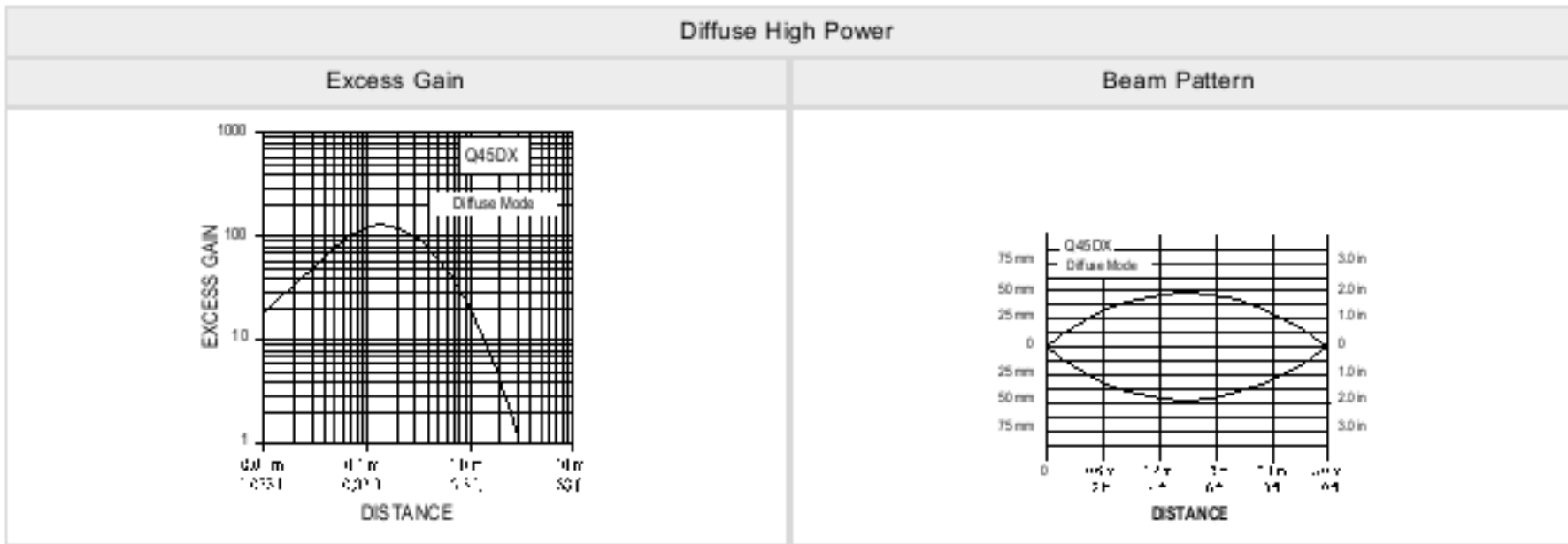

Convergent mode performance curves are based on a 90% reflectance white test card.

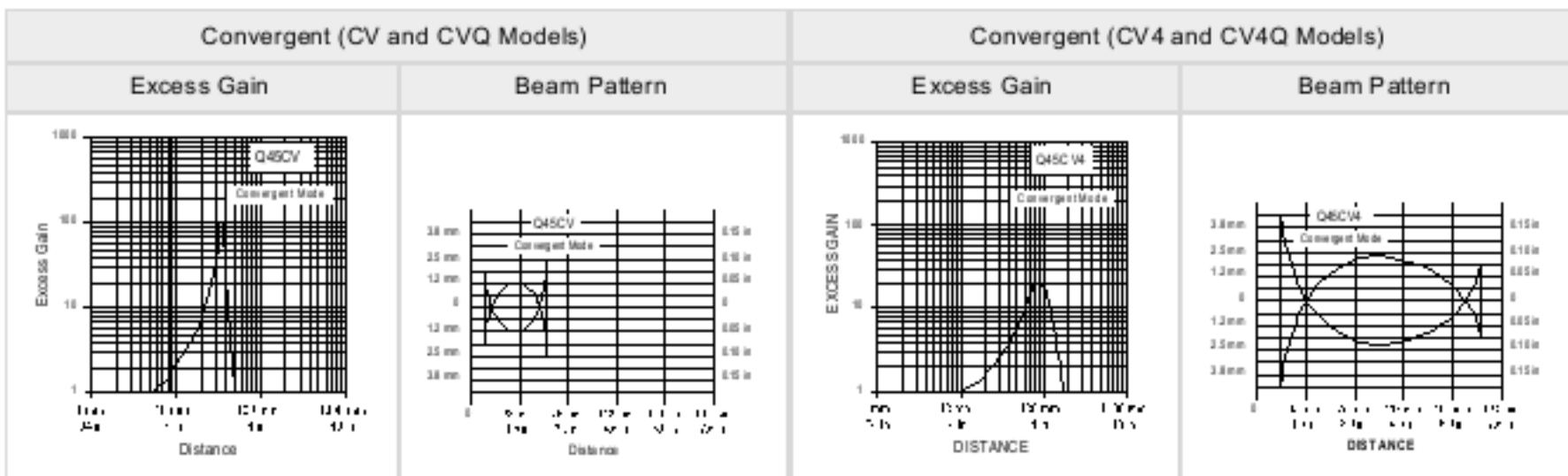

Glass fiber optic Diffuse mode performance curves are based on a 90% reflectance white test card.

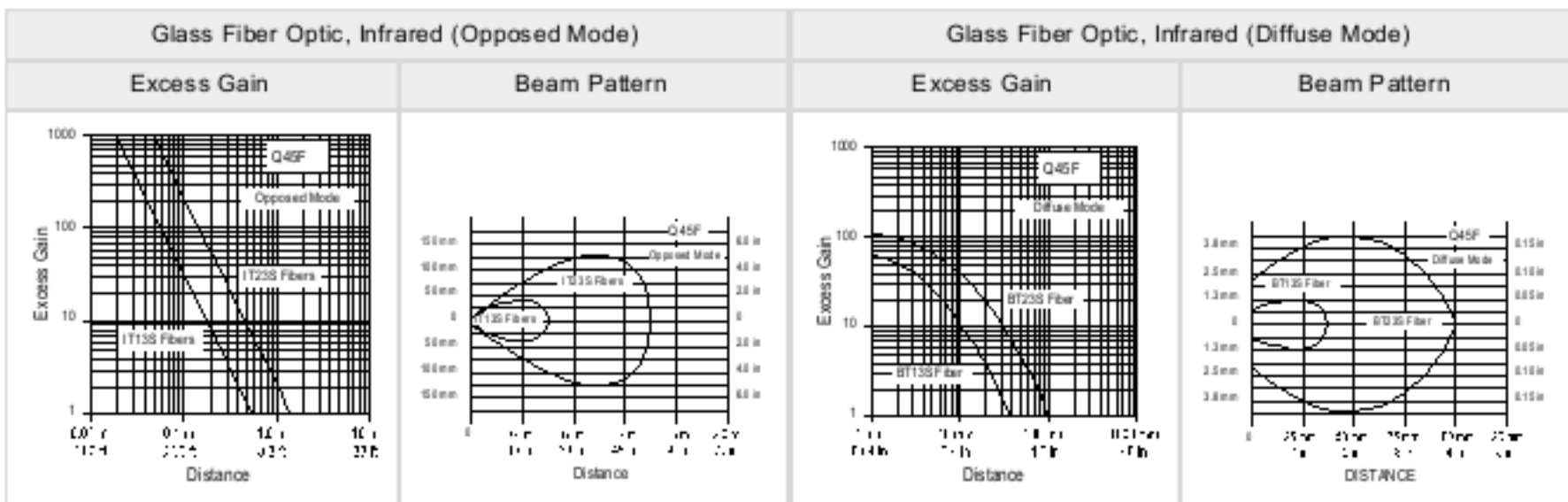

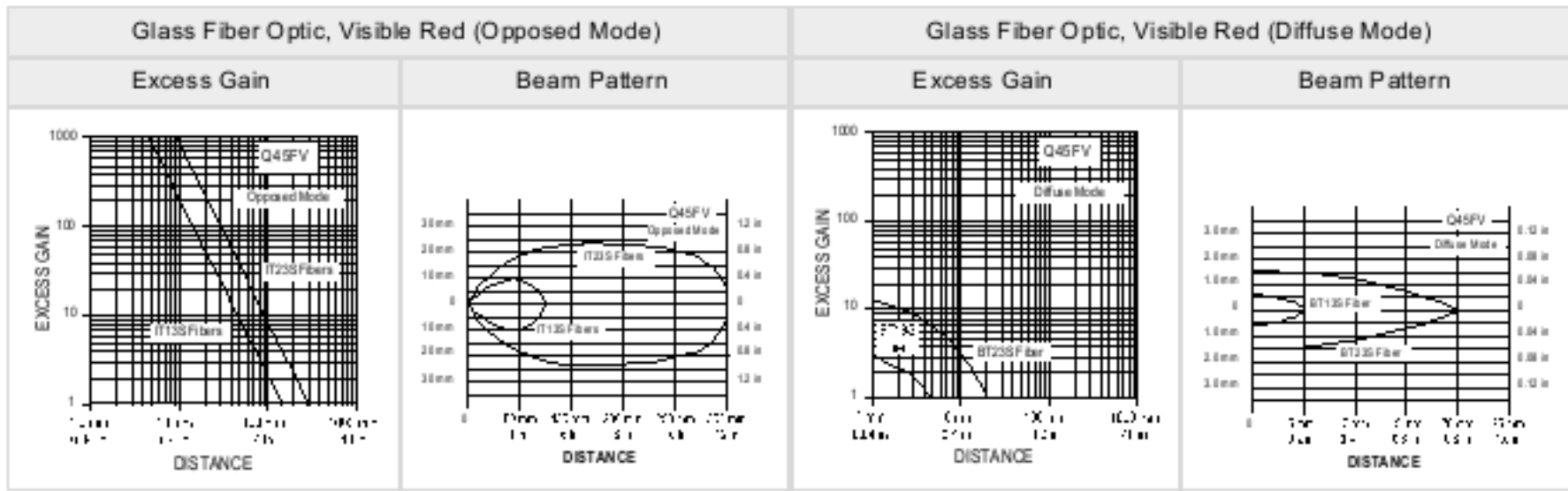

Plastic fiber optic Diffuse mode performance curves are based on a 90% reflectance white test card.

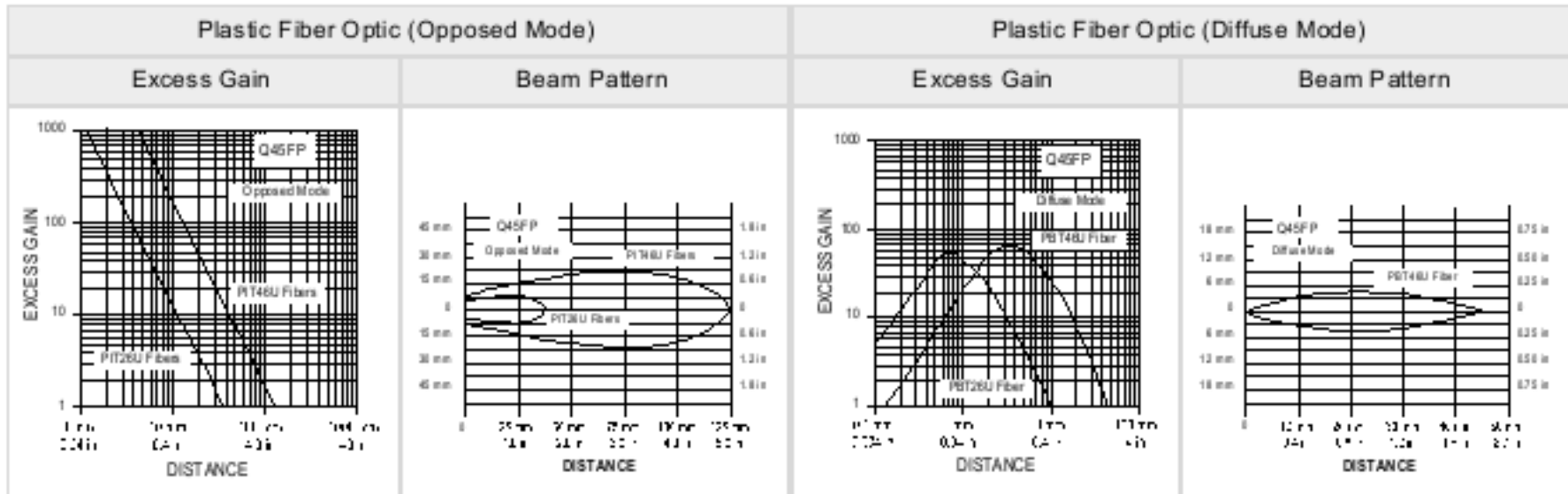

Accessories

Cordsets

3-pin Single-Ended 7/8-in Female Cordsets				
Model	Length	Style	Dimensions	Pinout (Female)
MBCC-308	1.83 m (6 ft)	Straight		<p>1 = Brown 3 = Blue 4 = Black</p>
MBCC-312	3.66 m (12 ft)			
MBCC-330	9.14 m (30 ft)			

5-Pin Single-Ended 7/8-in Female Cordsets				
Model	Length	Style	Dimensions	Pinout (Female)
MBCC-506	1.83 m (6 ft)	Straight		<p>1 = Black 2 = Blue 3 = Yellow 4 = Brown 5 = White</p>
MBCC-512	3.66 m (12 ft)			
MBCC-530	9.14 m (30 ft)			

Retroreflective Targets

Banner offers a wide selection of high quality retroreflective targets. See www.bannerengineering.com for complete information.

NOTE: Polarized sensors require corner cube-type retroreflective targets. Non-polarized sensors may use any retroreflective target.



Brackets

SMB30C

- 30 mm split clamp, black PBT bracket
- Stainless steel mounting hardware included
- Mounting hole for 30 mm sensor

Hole center spacing: A = \varnothing 45
Hole size: B = \varnothing 27.2

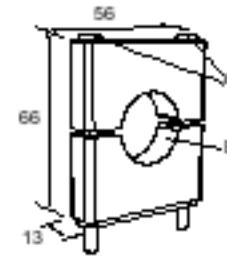

SMB30MM

- 12-gauge stainless steel bracket with curved mounting slots for versatile orientation
- Clearance for M6 (1/4 in) hardware
- Mounting hole for 30 mm sensor

Hole center spacing: A = 51, A to B = 25.4
Hole size: A = 42.6 x 7, B = \varnothing 6.4, C = \varnothing 30.1

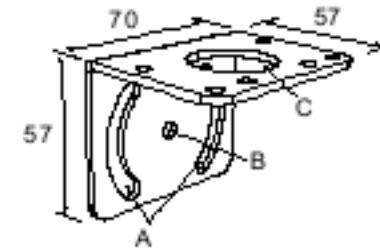

SMB30SC

- Swivel bracket with 30 mm mounting hole for sensor
- Black reinforced thermoplastic polyester
- Stainless steel mounting and swivel locking hardware included

Hole center spacing: A = \varnothing 50.8
Hole size: A = \varnothing 7.0, B = \varnothing 30.0

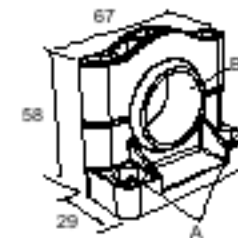

Output Timing Logic and Signal Strength Display Modules

Q45 sensors easily accept the addition of output timing logic and signal strength display functions. Display modules have a seven-element display that gives a more precise indication of excess gain than does the AID™ system LED that is standard on Q45 sensors. The modules listed below may be used with all Q45VR3 sensors. Refer to the module's datasheet for more information.

Models	Logic and/or Display Function
45LM58	Programmable output timing logic
45LM58D	Programmable output timing logic plus signal strength display
45LMD	Signal strength display only (no timing function)

Banner Engineering Corp Limited Warranty

Banner Engineering Corp. warrants its products to be free from defects in material and workmanship for one year following the date of shipment. Banner Engineering Corp. will repair or replace, free of charge, any product of its manufacture which, at the time it is returned to the factory, is found to have been defective during the warranty period. This warranty does not cover damage or liability for misuse, abuse, or the improper application or installation of the Banner product.

THIS LIMITED WARRANTY IS EXCLUSIVE AND IN LIEU OF ALL OTHER WARRANTIES WHETHER EXPRESS OR IMPLIED (INCLUDING, WITHOUT LIMITATION, ANY WARRANTY OF MERCHANTABILITY OR FITNESS FOR A PARTICULAR PURPOSE), AND WHETHER ARISING UNDER COURSE OF PERFORMANCE, COURSE OF DEALING OR TRADE USAGE.

This Warranty is exclusive and limited to repair or, at the discretion of Banner Engineering Corp., replacement. IN NO EVENT SHALL BANNER ENGINEERING CORP. BE LIABLE TO BUYER OR ANY OTHER PERSON OR ENTITY FOR ANY EXTRA COSTS, EXPENSES, LOSSES, LOSS OF PROFITS, OR ANY INCIDENTAL, CONSEQUENTIAL OR SPECIAL DAMAGES RESULTING FROM ANY PRODUCT DEFECT OR FROM THE USE OR INABILITY TO USE THE PRODUCT, WHETHER ARISING IN CONTRACT OR WARRANTY, STATUTE, TORT, STRICT LIABILITY, NEGLIGENCE, OR OTHERWISE.

Banner Engineering Corp. reserves the right to change, modify or improve the design of the product without assuming any obligations or liabilities relating to any product previously manufactured by Banner Engineering Corp. Any misuse, abuse, or improper application or installation of this product or use of the product for personal protection applications when the product is identified as not intended for such purposes will void the product warranty. Any modifications to this product without prior express approval by Banner Engineering Corp will void the product warranties. All specifications published in this document are subject to change; Banner reserves the right to modify product specifications or update documentation at any time. Specifications and product information in English supersede that which is provided in any other language. For the most recent version of any documentation, refer to: www.bannerengineering.com.

For patent information, see www.bannerengineering.com/patents.