

TL50 Basic Wireless Andon Tower Light Instruction Manual



Features

Multi-Color and Audible Andon Indicators

- Rugged, cost-effective, and easy-to-install Andon indicators
- Illuminated tower light segments and Andon box indicators provide easy-to-see status
- Four available colors: blue, green, yellow, and red
- Integral four capacitive touch button controller with status LEDs
- Steady or flashing status capability
- 300 mm pre-assembled stand-off pipe length
- Two wireless ISM radio options: 900 MHz and 2.4 GHz

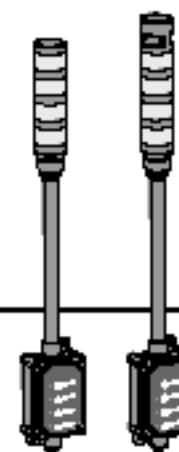

Models

Model	LCA130T Controller Radio Frequency	Tower Light Description
LCA130T4DXN2-TL50BGYR300Q	2.4 GHz	TL50 Basic Andon Tower Light (Blue, Green, Yellow, Red)
LCA130T4DXN9-TL50BGYR300Q	900 MHz	TL50 Basic Andon Tower Light (Blue, Green, Yellow, Red)

TL50-LCA130T Switch Diagrams

The control box status LED mimics the tower light status in color and animation.

Touch one of the buttons to turn the corresponding LED and output on or off. Touch and hold the button to continuously flash the corresponding LED and output on or off.

LED Key:

- 1 = Blue
- 2 = Green
- 3 = Yellow
- 4 = Red

Input Pinout - All Models

5-pin M12 Male Connector	Pin	Wire Color	Wiring Description
	1	Brown (bn)	18 V DC to 30 V DC
	2	White (wh)	Not used
	3	Blue (bu)	DC common (GND)
	4	Black (bk)	Not used
	5	Gray (gy)	Not used



Configuration Instructions

LCA130T DIP Switches

Before applying power to the device, set the radio's DIP switches.

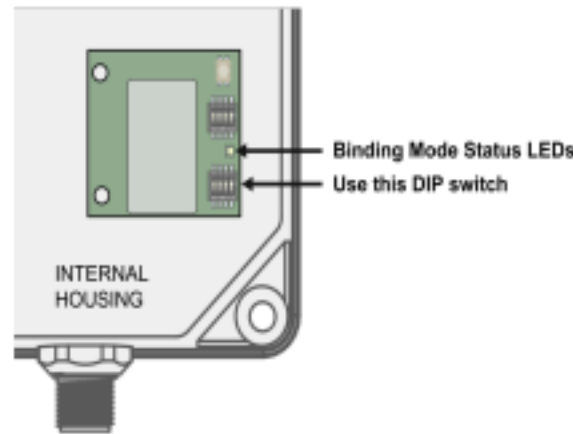

Device Settings ⁽¹⁾	DIP Switches			
	1 ⁽²⁾	2	3	4
Transmit Power Level: 500 mW (default setting)	OFF			
Transmit Power Level: 250 mW	ON			
Bit-Packed Button / LED and Output Status: Input 1: ENABLED Output 1 Overwrite Input Status: ENABLED (default setting)		OFF	OFF	OFF
Conventional Button / LED and Output Status: Inputs 2-6 (OFF = 0, Steady = 1, Flashing = 2): ENABLED Outputs 2-6 (Overwrite Input Status): ENABLED		ON	OFF	OFF
Bit-Packed Button / LED and Output Status: Input 1: ENABLED Output 1 Overwrite Input Status: DISABLED		OFF	ON	OFF
Conventional Button / LED and Output Status: Inputs 2-6 (OFF = 0, Steady = 1, Flashing = 2): ENABLED Outputs 2-6 (Overwrite Input Status): DISABLED		ON	ON	OFF

Bind the LCA130T to a DXM and Assign the Device Address

Before beginning the binding procedure, apply power to all the devices. Separate the radios by two meters when running the binding procedure. Put only one DXM into binding mode at a time to prevent the LCA 130T from binding to the wrong DXM.

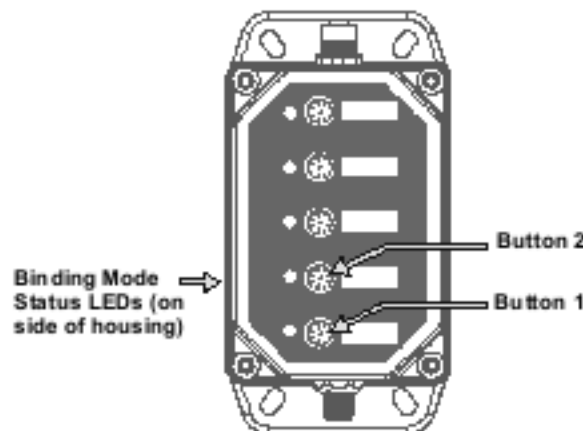

1. On the DXM: Use the arrow keys to select the ISM Radio menu on the LCD and click ENTER.
2. Highlight the Binding menu and click ENTER.
3. Use the arrow keys to select the Node address to bind the LCA130T to.
4. On the LCA130T, enter binding mode:
 - a. Touch and hold button 1.

⁽¹⁾ Default device settings are shown.

⁽²⁾ DIP Switch 1 is only used on 900 MHz models.

- b. Triple-touch button 2.
- c. Release button 1.

The red and green Binding Mode Status LEDs flash alternately and the sensor searches for a DXM in binding mode. After the LCA130T binds, the LEDs stay solid momentarily, then they flash together four times. The LCA130T exits binding mode.

5. Label the LCA130T with the Node address number for future reference.
6. On the DXM: Click BACK to exit binding for that specific Node address.
7. Repeat steps 3 through 6 and change the Node address for as many LCA130Ts as are needed for your network.
8. On the DXM: After you have finished forming your network, click BACK until you reach the main menu.

LED Behavior for the Nodes

Nodes do not sample inputs until they are communicating with the Gateway. The radios and antennas must be a minimum distance apart to function properly. Recommended minimum distances are:

- 900 MHz (500 mW): 4.57 m (15 ft)
- 2.4 GHz (65 mW): 0.3 m (1 ft)

Binding Mode Status LEDs	Node Status
Flashing green	Radio link okay
Green and red flashing alternately	In Binding mode
Both colors are solid for 4 seconds, then flash 4 times; looks amber	Binding mode is complete
Flashing red once every 3 seconds	Radio link error
Flashing red once every second	Device error

LCA130T Modbus Registers

Holding registers

Modbus Registers		EIP Registers		I/O Type	I/O Range		Holding Register Representation (DEC)	
Gateway	Node	Node			Min	Max	Min	Max
1	1 + (Node# x 16)	0 + (Node# x 8)	Instance 100 / N7	Bit Packed Input	0	682	0	682
2	2 + (Node# x 16)	1 + (Node# x 8)		Button 1 Input 1	0	2	0	2
3	3 + (Node# x 16)	2 + (Node# x 8)		Button 2 Input 2	0	2	0	2
4	4 + (Node# x 16)	3 + (Node# x 8)		Button 3 Input 3	0	2	0	2
5	5 + (Node# x 16)	4 + (Node# x 8)		Button 4 Input 4	0	2	0	2
6	6 + (Node# x 16)	5 + (Node# x 8)		Button 5 Input 5	0	2	0	2
7	7 + (Node# x 16)	6 + (Node# x 8)		Reserved				
8	8 + (Node# x 16)	7 + (Node# x 8)		Device Message				
9	9 + (Node# x 16)	8 + (Node# x 8)	Instance 112 / N14	Bit Packed Output	0	682	0	682
10	10 + (Node# x 16)	9 + (Node# x 8)		Button 1 Output 1	0	2	0	2
11	11 + (Node# x 16)	10 + (Node# x 8)		Button 2 Output 2	0	2	0	2
12	12 + (Node# x 16)	11 + (Node# x 8)		Button 3 Output 3	0	2	0	2
13	13 + (Node# x 16)	12 + (Node# x 8)		Button 4 Output 4	0	2	0	2
14	14 + (Node# x 16)	13 + (Node# x 8)		Button 5 Output 5	0	2	0	2
15	15 + (Node# x 16)	14 + (Node# x 8)		Control Message	0	2	0	2
16	16 + (Node# x 16)	15 + (Node# x 8)		Reserved	0	2	0	2

To ensure that the LCA130T holds the correct state in case of signal interference, read the button input registers on the LCA130T, and then use the gateway to write the matching value to the button output registers on the LCA130T.

Bit-Packed Holding Register Representation

Buttons	Summed Bit-Packed Register Contents of the LCA130T	
	Touch Value	Touch and Hold Value
Button 1	1	2
Button 2	4	8

Continued on page 4

Continued from page 3

Summed Bit-Packed Register Contents of the LCA130T		
Buttons	Touch Value	Touch and Hold Value
Button 3	16	32
Button 4	64	128
Button 5	256	512

By default, an LED and an output are on steady when the corresponding button is touched and released immediately. An LED and an output continuously flash on and off when the button is touched and held for one second. Combinations of button touches and holds are summed.

For example, the value held in register 1 is 6 (2 + 4) when button 1 is flashing (2) and button 2 (4) is steady.

Conventional Button holding Register Representation

Value	Description
0	LED and output off
1	Touch: LED and output are on steady
2	Touch and Hold: LED and output are flashing on and off

Specifications

Supply Voltage and Current

- 18 V DC to 30 V DC
- Segments—maximum current per LED segment: 45 mA at 18 V DC to 30 V DC
- Omni-Directional Audible Alarm: 25 mA maximum current

Supply Protection Circuitry

- Protected against transient voltages

Input Response Time

- Indicator On/Off: 10 milliseconds maximum

Operating Frequency

- 2.7 kHz ± 500 Hz oscillation frequency
- Audible Intensity: 92 dB at 1 m (typical)

Connections

- Integral 5-pin M12 quick-disconnect connector
- Models with a quick disconnect require a mating cordset

Construction

- Bases and Covers: Polycarbonate
- Light Segment: Polycarbonate

Radio Range

- A 2 dB antenna ships with this device.
- Transmit power and range are subject to many factors, including antenna gain, installation methods, characteristics of the application, and environmental conditions.
- Please refer to the following documents for installation instructions and high-gain antenna options.
 - Installing Your Sure Cross® Radios ([151514](#))
 - Conducting a Site Survey ([133602](#))
 - Sure Cross® Antenna Basics ([132113](#))

Antenna Minimum Separation Distance

- 900 MHz radios transmitting at ≥ 500 mW: 4.57 m (15 ft) with the supplied antenna
- 2.4 GHz radios transmitting at 65 mW: 0.3 m (1 ft) with the supplied antenna

Radio Transmit Power

- 900 MHz Conducted: 27 dBm (500 mW); EIRP with the supplied antenna: < 36 dBm
- 2.4 GHz Conducted: < 18 dBm (65 mW); EIRP with the supplied antenna: < 20 dBm (100 mW)

Vibration and Mechanical Shock

- Meets IEC 60068-2-6 requirements (Vibration: 10 Hz to 55 Hz, 0.5 mm amplitude, 5 minutes sweep, 30 minutes dwell)
- Meets IEC 60068-2-27 requirements (Shock: 15G 11 ms duration, half sine wave)

Operating Conditions

- Non-Audible: -40 °C to +50 °C (-40 °F to +122 °F)
- Audible: -20 °C to +50 °C (-4 °F to +122 °F)
- 95% at +50 °C maximum relative humidity (non-condensing)

Environmental Rating

- Assembly: IP54
- Stand-alone tower light: IP65

Indicator Characteristics

Color	Dominant Wavelength (nm) or Color Temperature (CCT)	Lumen Output (Typical at 25 °C)
Green	525 nm	16.5
Red	625 nm	6
Yellow	590 nm	15
Blue	465 nm	4

Spread Spectrum Technology

- FHSS (Frequency Hopping Spread Spectrum)
- 900 MHz Compliance (SX7023EXT Radio Module)
 - Radio module is indicated by the product label marking
 - Contains FCC ID: UE3SX7023EXT
 - Contains IC: 7044A-SX7023EXT
- 2.4 GHz Compliance (SX243 Radio Module)
 - Radio module is indicated by the product label marking
 - Contains FCC ID: UE3SX243
 - Radio Equipment Directive (RED) 2014/53/EU
 - Contains IC: 7044A-SX243

Certifications

CE/UKCA approval only applies to 2.4 GHz models

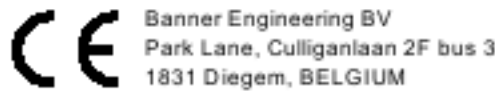

Banner Engineering BV
Park Lane, Culliganlaan 2F bus 3
1831 Diegem, BELGIUM



Turck Banner LTD Blenheim House
Blenheim Court
Wickford, Essex SS11 8YT
GREAT BRITAIN



Agência Nacional de Telecomunicações 03737-22-04042

Required Overcurrent Protection



WARNING: Electrical connections must be made by qualified personnel in accordance with local and national electrical codes and regulations.

Overcurrent protection is required to be provided by end product application per the supplied table.

Overcurrent protection may be provided with external fusing or via Current Limiting, Class 2 Power Supply.

Supply wiring leads < 24 AWG shall not be spliced.

For additional product support, go to www.bannerengineering.com.

Supply Wiring (AWG)	Required Overcurrent Protection (A)	Supply Wiring (AWG)	Required Overcurrent Protection (A)
20	5.0	26	1.0
22	3.0	28	0.8
24	1.0	30	0.5

FCC Part 15 Class A for Intentional Radiators

This equipment has been tested and found to comply with the limits for a Class A digital device, pursuant to Part 15 of the FCC Rules. These limits are designed to provide reasonable protection against harmful interference when the equipment is operated in a commercial environment. This equipment generates, uses, and can radiate radio frequency energy and, if not installed and used in accordance with the instruction manual, may cause harmful interference to radio communications. Operation of this equipment in a residential area is likely to cause harmful interference in which case the user will be required to correct the interference at his own expense.

(Part 15.21) Any changes or modifications not expressly approved by the party responsible for compliance could void the user's authority to operate this equipment.

Industry Canada Statement for Intentional Radiators

This device complies with the licence exempt transmitter(s)/receiver(s) that comply with Innovation, Science and Economic Development Canada's licence exempt RSS(s). Operation is subject to the following two conditions:

1. This device may not cause interference.
2. This device must accept any interference, including interference that may cause undesired operation of the device.

Cet appareil convient des émetteurs/récepteurs exempts de licence conformes à la norme Innovation, Sciences et Développement économique Canada. L'exploitation est autorisée aux deux conditions suivantes:

1. L'appareil ne doit pas produire de brouillage.
2. L'utilisateur de l'appareil doit accepter tout brouillage radioélectrique subi, même si le brouillage est susceptible d'en compromettre le fonctionnement.

ANATEL

Este equipamento não tem direito à proteção contra interferência prejudicial e não pode causar interferência em sistemas devidamente autorizados. Para maiores informações, consulte o site da ANATEL www.gov.br/anatel/pt-br/



Dimensions

All measurements are listed in millimeters [inches], unless noted otherwise. The measurements provided are subject to change.

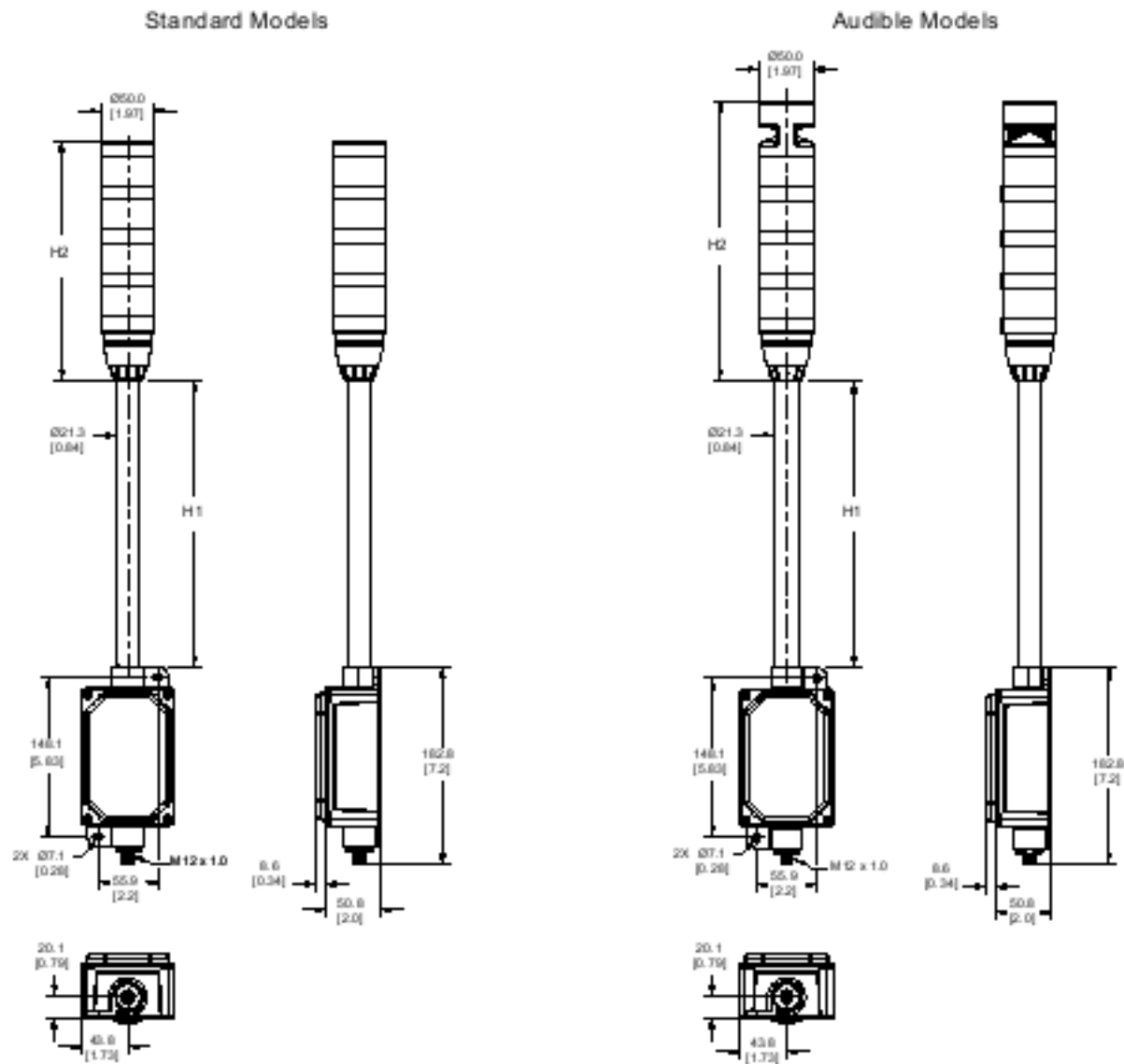

Stand-Off Pole Height (H1)

Model	Stand-Off
LCA..TL50..300	300 mm (11.81 in)

Tower Light Height (H2)

# of Segments	Standard	Audible
3	180.9 mm (7.12 in)	220.0 mm (8.66 in)
4	221.8 mm (8.72 in)	260.7 mm (10.26 in)

Accessories

Power Supplies

PSW-24-1

- 24 V DC, 1 A Class 2 UL Listed power supply
- 100 V AC to 240 V AC 50/60 Hz input
- 2 m (6.5 ft) PVC cable with M12 quick disconnect
- Includes Type A (US, Canada, Japan, Puerto Rico, Taiwan), Type C (Germany, France, South Korea, Netherlands, Poland, Spain, Turkey), Type G (United Kingdom, Ireland, Singapore, Vietnam), and Type I (China, Australia, New Zealand) AC detachable input plugs



PSW-24-2

- 24 V DC, 2 A Class 2 UL Listed power supply
- 100 V AC to 240 V AC 50/60 Hz input
- 3.5 m (11.5 ft) PVC cable with M12 quick disconnect
- Includes Type A (US, Canada, Japan, Puerto Rico, Taiwan), Type C (Germany, France, South Korea, Netherlands, Poland, Spain, Turkey), Type G (United Kingdom, Ireland, Singapore, Vietnam), and Type I (China, Australia, New Zealand) AC detachable input plugs

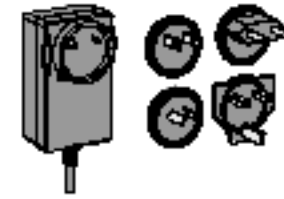

Cordsets

4-Pin Single-Ended M12 Female Cordsets				
Model	Length	Style	Dimensions	Pinout (Female)
MQDC-408	2 m (6.56 ft)	Straight		
MQDC-415	5 m (16.4 ft)			
MQDC-430	9 m (29.5 ft)			
MQDC-450	15 m (49.2 ft)			
MQDC-408RA	2 m (6.56 ft)	Right Angle		
MQDC-415RA	5 m (16.4 ft)			
MQDC-430RA	9 m (29.5 ft)			
MQDC-450RA	15 m (49.2 ft)			

1 = Brown
 2 = White
 3 = Blue
 4 = Black
 5 = Unused

4 Pin Threaded M12 Cordsets—Double Ended				
Model	Length	Style	Dimensions	Pinout
MQDEC-401SS	0.31 m (1 ft)	Male Straight/Female Straight		<p>Female</p>
MQDEC-403SS	0.91 m (2.99 ft)			
MQDEC-406SS	1.83 m (6 ft)			
MQDEC-412SS	3.66 m (12 ft)			
MQDEC-420SS	6.10 m (20 ft)			
MQDEC-430SS	9.14 m (30.2 ft)			
MQDEC-450SS	15.2 m (49.9 ft)	Male Right-Angle/Female Straight		<p>Male</p>
MQDEC-403RS	0.91 m (2.99 ft)			
MQDEC-406RS	1.83 m (6 ft)			
MQDEC-412RS	3.66 m (12 ft)			
MQDEC-420RS	6.10 m (20 ft)			
MQDEC-430RS	9.14 m (30.2 ft)			
MQDEC-450RS	15.2 m (49.9 ft)			<p>1 = Brown 2 = White 3 = Blue 4 = Black</p>

Banner Engineering Corp Limited Warranty

Banner Engineering Corp. warrants its products to be free from defects in material and workmanship for one year following the date of shipment. Banner Engineering Corp. will repair or replace, free of charge, any product of its manufacture which, at the time it is returned to the factory, is found to have been defective during the warranty period. This warranty does not cover damage or liability for misuse, abuse, or the improper application or installation of the Banner product.

THIS LIMITED WARRANTY IS EXCLUSIVE AND IN LIEU OF ALL OTHER WARRANTIES WHETHER EXPRESS OR IMPLIED (INCLUDING, WITHOUT LIMITATION, ANY WARRANTY OF MERCHANTABILITY OR FITNESS FOR A PARTICULAR PURPOSE), AND WHETHER ARISING UNDER COURSE OF PERFORMANCE, COURSE OF DEALING OR TRADE USAGE.

This Warranty is exclusive and limited to repair or, at the discretion of Banner Engineering Corp., replacement. IN NO EVENT SHALL BANNER ENGINEERING CORP. BE LIABLE TO BUYER OR ANY OTHER PERSON OR ENTITY FOR ANY EXTRA COSTS, EXPENSES, LOSSES, LOSS OF PROFITS, OR ANY INCIDENTAL, CONSEQUENTIAL OR SPECIAL DAMAGES RESULTING FROM ANY PRODUCT DEFECT OR FROM THE USE OR INABILITY TO USE THE PRODUCT, WHETHER ARISING IN CONTRACT OR WARRANTY, STATUTE, TORT, STRICT LIABILITY, NEGLIGENCE, OR OTHERWISE.

Banner Engineering Corp. reserves the right to change, modify or improve the design of the product without assuming any obligations or liabilities relating to any product previously manufactured by Banner Engineering Corp. Any misuse, abuse, or improper application or installation of this product or use of the product for personal protection applications when the product is identified as not intended for such purposes will void the product warranty. Any modifications to this product without prior express approval by Banner Engineering Corp will void the product warranties. All specifications published in this document are subject to change; Banner reserves the right to modify product specifications or update documentation at any time. Specifications and product information in English supersede that which is provided in any other language. For the most recent version of any documentation, refer to: www.bannerengineering.com.

For patent information, see www.bannerengineering.com/patents.