

## Features

Precision edge measurement sensor for web alignment, small part detection, and width measurement.

- High-resolution measurement ensures material is properly positioned to improve quality and yield
  - \* Less than 10-micron resolution precisely monitors edge movement to maximize process control and reduce wasted material
  - \* 2 kHz measurement frequency rapidly measures edge location, enabling quick corrections to material position
- Wide sensing beam allows for precision measurement over a large area
  - \* 40-millimeter sensing range measures with the same resolution at any distance, allowing for edge movement between the sensor face and reflector
  - \* 24-millimeter wide beam allows for variation in target presentation, which reduces fixturing complexity and provides more reliable detection than a single-point sensor
- A selection of measurement modes precisely track edges across a broad variety of moving materials, including a wide range of opacities and textures
  - \* Single Edge for tracking and positioning of web and sheet edges with materials such as foils, films, metals, plastics, or paper
  - \* Width or Gap for confirming quality of a product or in process dimension verification

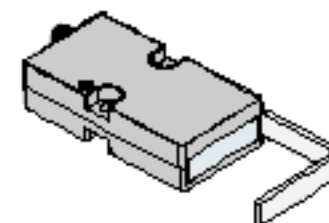

### WARNING:

- Do not use this device for personnel protection
- Using this device for personnel protection could result in serious injury or death.
- This device does not include the self-checking redundant circuitry necessary to allow its use in personnel safety applications. A device failure or malfunction can cause either an energized (on) or de-energized (off) output condition.

## Models

Family	Beam Width	-	Output	Sensing Mode	-	Connector	Analog Wire
EG	24	-	I	LVA	-	Q7	B
EG	24 = 24 mm (0.94 in)		I = 4 mA to 20 mA	LVA = Attached Retroreflective LVX = Detached Retroreflective		Q7 = Integral 4 pin M8	Blank = white wire B = Black wire

## Overview

The EG24 can accurately track a target within its 24 mm (0.94 in) wide field of view. It is ideal for tracking the edge of a web or the location or thickness of a thin target like a thread or wire.

The single-edge and double-edge tracking measurement modes can be configured, depending on the application. Connect the RSD can for additional configuration options, including other measurement modes.

## Features and Indicators

	Feature	Description	
	1	Green LED	Power indicator
	2	Amber LED	Output indicator
	3	TEACH button	Mode selection and teach
	4	Connector	4-pin, M8

## Installation

Attach the retroreflective arm using the two included bolts.

Alternatively, adhere retroreflective tape and mount the EG24 pointing at the retroreflective tape.

**IMPORTANT:** If using the alternate method, the included retroreflective tape must be used. Performance cannot be guaranteed if using a different reflector than the one provided.

## Mount the Device

1. If a bracket is needed, mount the device onto the bracket.
2. Mount the device (or the device and the bracket) to the machine or equipment at the desired location. Do not tighten the mounting screws at this time.
3. Check the device alignment.
4. Tighten the mounting screws to secure the device (or the device and the bracket) in the aligned position.

## Wiring

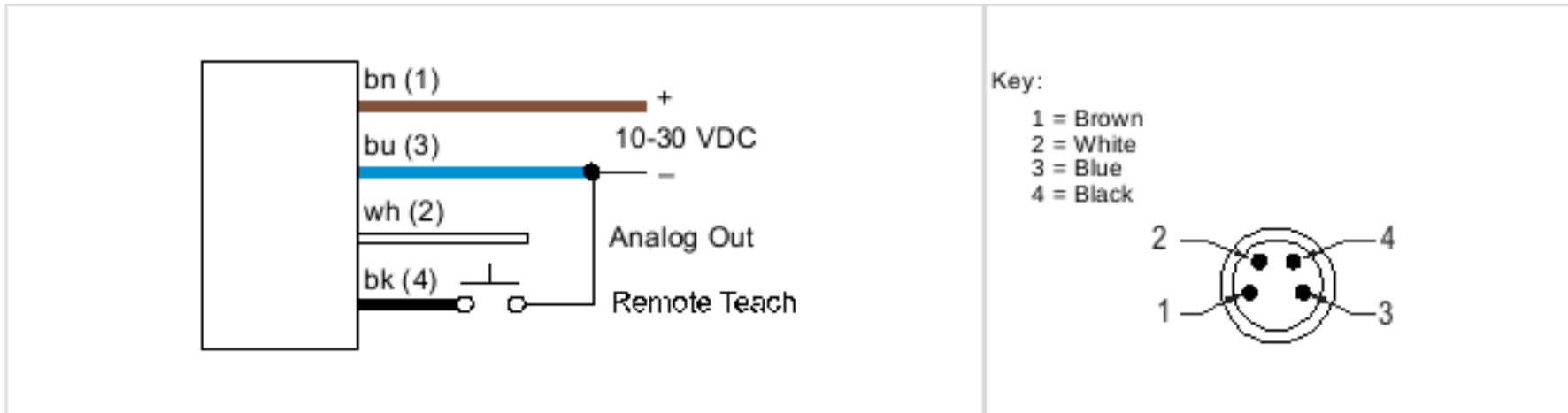

**NOTE:** For model EG24-ILVA-Q7B, the analog output is on the black wire (pin 4) and the remote teach is on the white wire (pin 2)

## Configure the Sensor

The default configuration scales the 4 mA to 20 mA output across the full width of the 24 mm (0.94 in) sensing beam.

Use the push button or remote teach input to create a smaller field of view.

If the amber LED flashes 3 times at any point during these TEACH processes, there is an error and the sensor is not able to set any valid set points. No changes are made to the current conditions.

## Remote Input

Use the remote input to program the sensor remotely.

The remote input provides limited programming options and is Active Low. For Active Low, connect the gray input wire to ground (0 V DC), with a remote switch connected between the wire and ground.

Pulse the remote input according to the diagram and the instructions provided in this manual.

The length of the individual programming pulses is equal to the value T: 0.04 seconds ≤ T ≤ 0.8 seconds.

The black wire is used for remote teach input.

**NOTE:** For model EG24-ILVA-Q7B, the analog output is on the black wire (pin 4) and the remote teach is on the white wire (pin 2)

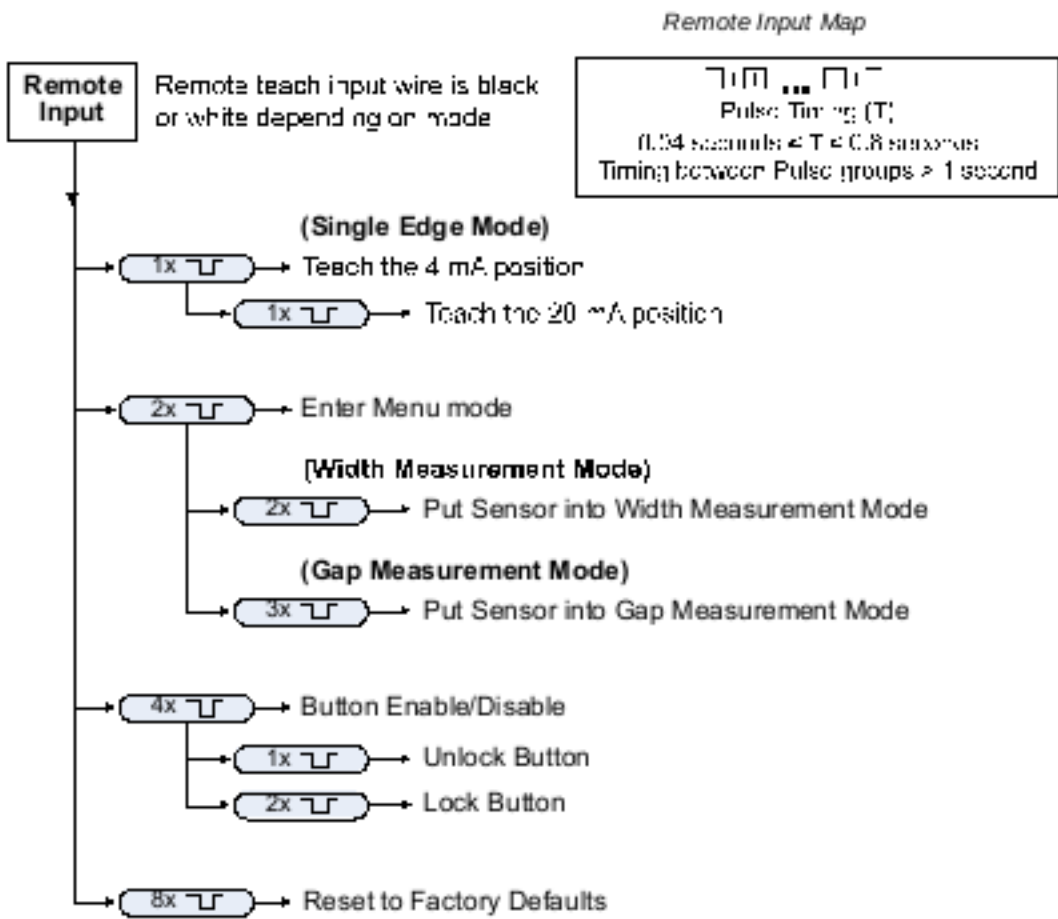

## TEACH the Sensor Using Single Edge

If a target is presenting only a single edge that is inside the field of view of the sensor, use the Single Edge TEACH to track the location of the target. This TEACH mode can be used to create a smaller field of view within the sensing beam.

*Single Edge Teach*

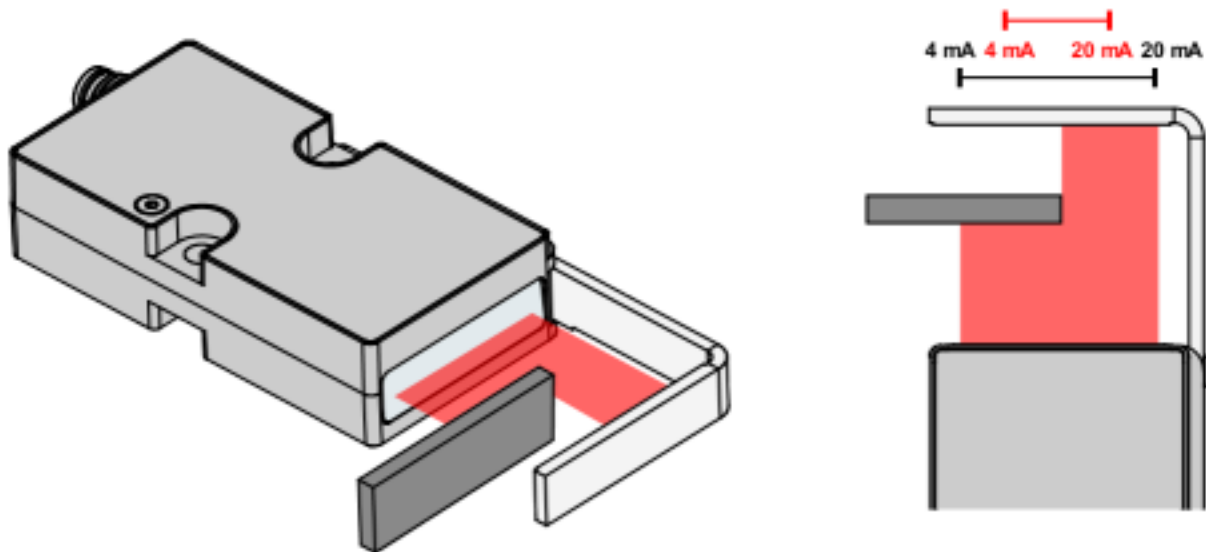

While most applications use the whole field of view, some applications may need a smaller field of view. Several options are available, depending on the use or placement of a target during the TEACH process:

**TEACH Cases**

Condition	Result
Teach both points while the window is clear.	Sets the 4 mA to 20 mA range across the whole field of view.
Teach two different points.	Sets the 4 mA point and the 20 mA point using the placement of a target during the TEACH process. This creates a smaller field of view.
Teach both points with the beam completely covered.	Sets a 20 mA to 4 mA range across the whole field of view.
Teach the same point twice.	Sets a minimum window, a 4 mA to 20 mA span, centered around that point.

To set the field of view, use the following instructions:

1. Put the sensor into TEACH mode.

Method	Action	Result
TEACH Button	Press and hold the TEACH button for two seconds.	The LEDs begin flashing and the sensor enters TEACH mode.
Remote Input	No action is required.	

- If the full field of view is desired, do not use a target for this procedure. If a smaller sensing area than the full field of view is desired, position the edge of the target within the field of view of the EG24. This will be the 4 mA point.
- Teach the 4 mA position.

Method	Action	Result
TEACH Button	Press the TEACH button one time.	The LEDs begin flashing twice and continue to flash twice in a pattern.
Remote Input	Single-pulse the remote input.	

- If a smaller sensing area than the full field of view is desired, move the edge of the target to where the 20 mA will be positioned or leave the target in place to teach the minimum window.
- Teach the 20 mA position.

Method	Action	Result
TEACH Button	Press the TEACH button one time.	The green LED flashes twice and the sensor returns to run mode.
Remote Input	Single-pulse the remote input.	

## TEACH the Sensor Using Width Measurement Mode

Width Measurement measures the distance between the two outermost edges. The sensor automatically sets the 4 mA to 20 mA span to the full width of the beam. No further TEACH is required.

Width Measurement TEACH

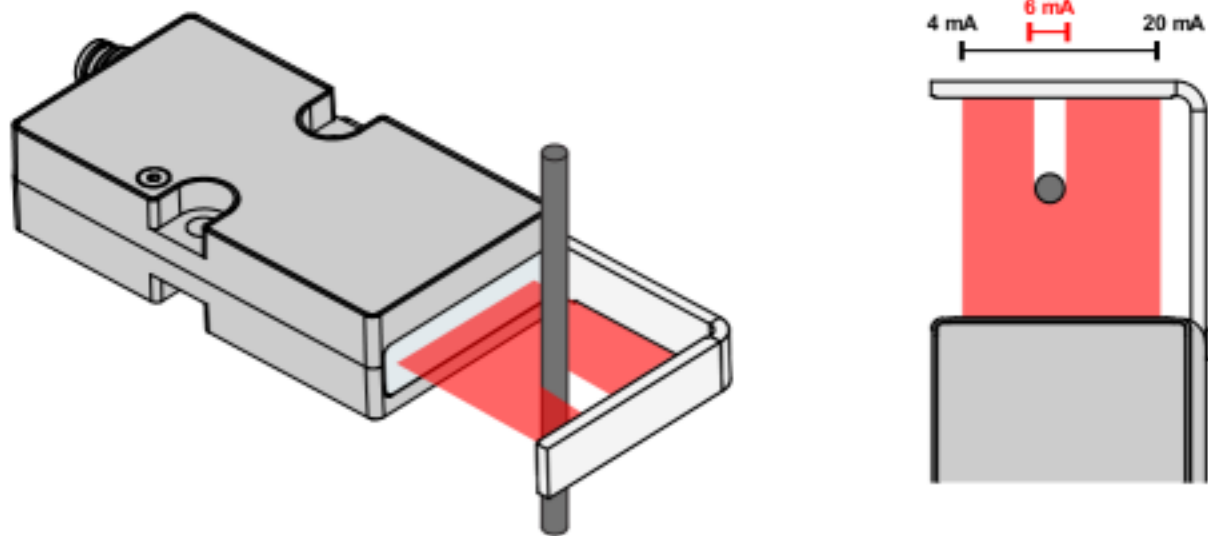

- Put the sensor into Menu mode.

Method	Action	Result
TEACH Button	Press and hold the TEACH button for two seconds.	The LEDs begin flashing and the sensor enters Menu mode.
Remote Input	Double-pulse the remote input.	

- Put Sensor into Width Measurement Mode.

Method	Action	Result
TEACH Button	Press the TEACH button two times.	The green LED flashes four times and the sensor returns to run mode.
Remote Input	Double-pulse the remote input.	

## TEACH the Sensor Using Gap Measurement Mode

Gap Measurement measures the width of a gap in the target. If multiple gaps are detected, they are added together.

Gap Measurement TEACH

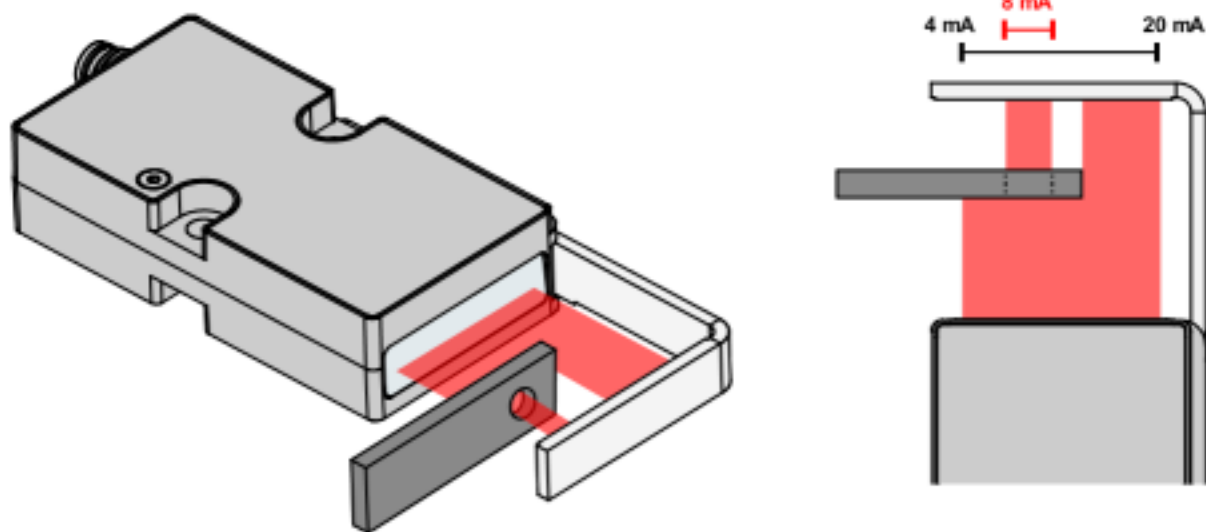

1. Put the sensor into Menu mode.

Method	Action	Result
TEACH Button	Press and hold the TEACH button for two seconds.	The LEDs begin flashing and the sensor enters Menu mode.
Remote Input	Double-pulse the remote input.	

2. Put the sensor into Gap Measurement Mode.

Method	Action	Result
TEACH Button	Press the TEACH button three times.	The green LED flashes six times and the sensor returns to run mode.
Remote Input	Triple-pulse the remote input.	

## Reset the Sensor to Factory Defaults

To reset the sensor to factory default, eight-pulse the remote input to apply the factory defaults. The green LED flashes 16 times and the sensor returns to run mode.

## Button Enable/Disable

1. Four-pulse the remote input.
2. Lock or unlock the buttons.

- \* To unlock: Single-pulse the remote input. The green LED flashes twice.
- \* To lock: Double-pulse the remote input. The green LED flashes four times.

## Specifications

Measuring Field Size 24 mm	Wave Length 630 nm
Measuring Range 0 mm to 40 mm	Response Time 0.65 ms
Resolution < 0.01 mm	Supply Voltage (Vcc) 10 V DC to 30 V DC
Repeatability 0.02 mm	Use only with a suitable Class 2 power supply (UL) or Limited Power Supply (CE)
Linearity ± 0.1 mm (0 - 40) mm	Power Consumption, exclusive of load 0.75 W
Measuring Frequency 2000 Hz	Output Circuit Analog
Measuring Distance (to Object) < 40 mm	Output Signal 4 mA to 20 mA

Supply Protection Circuitry

Protected against reverse polarity and output short-circuit

Analog Current Output Maximum Load

$$\frac{(V_{cc} - 3.5)}{0.02} \Omega$$

Construction

Housing: Die Cast Zinc

Window: Acrylic

Retroreflector Arm: Stainless Steel

Operating Conditions

0 °C to +55 °C (+32 °F to +131 °F)

Environmental Rating

IP67

Required Overcurrent Protection



**WARNING:** Electrical connections must be made by qualified personnel in accordance with local and national electrical codes and regulations.

Overcurrent protection is required to be provided by end product application per the supplied table.

Overcurrent protection may be provided with external fusing or via Current Limiting, Class 2 Power Supply.

Supply wiring leads < 24 AWG shall not be spliced.

For additional product support, go to [www.bannerengineering.com](http://www.bannerengineering.com).

Supply Wiring (AWG)	Required Overcurrent Protection (A)	Supply Wiring (AWG)	Required Overcurrent Protection (A)
20	5.0	26	1.0
22	3.0	28	0.8
24	1.0	30	0.5

Certifications



Banner Engineering BV  
Park Lane, Culliganlaan 2F bus 3  
1831 Diegem, BELGIUM



Turck Banner LTD Blenheim House  
Blenheim Court  
Wickford, Essex SS 11 8YT  
GREAT BRITAIN

## Dimensions

All measurements are listed in millimeters [inches], unless noted otherwise.

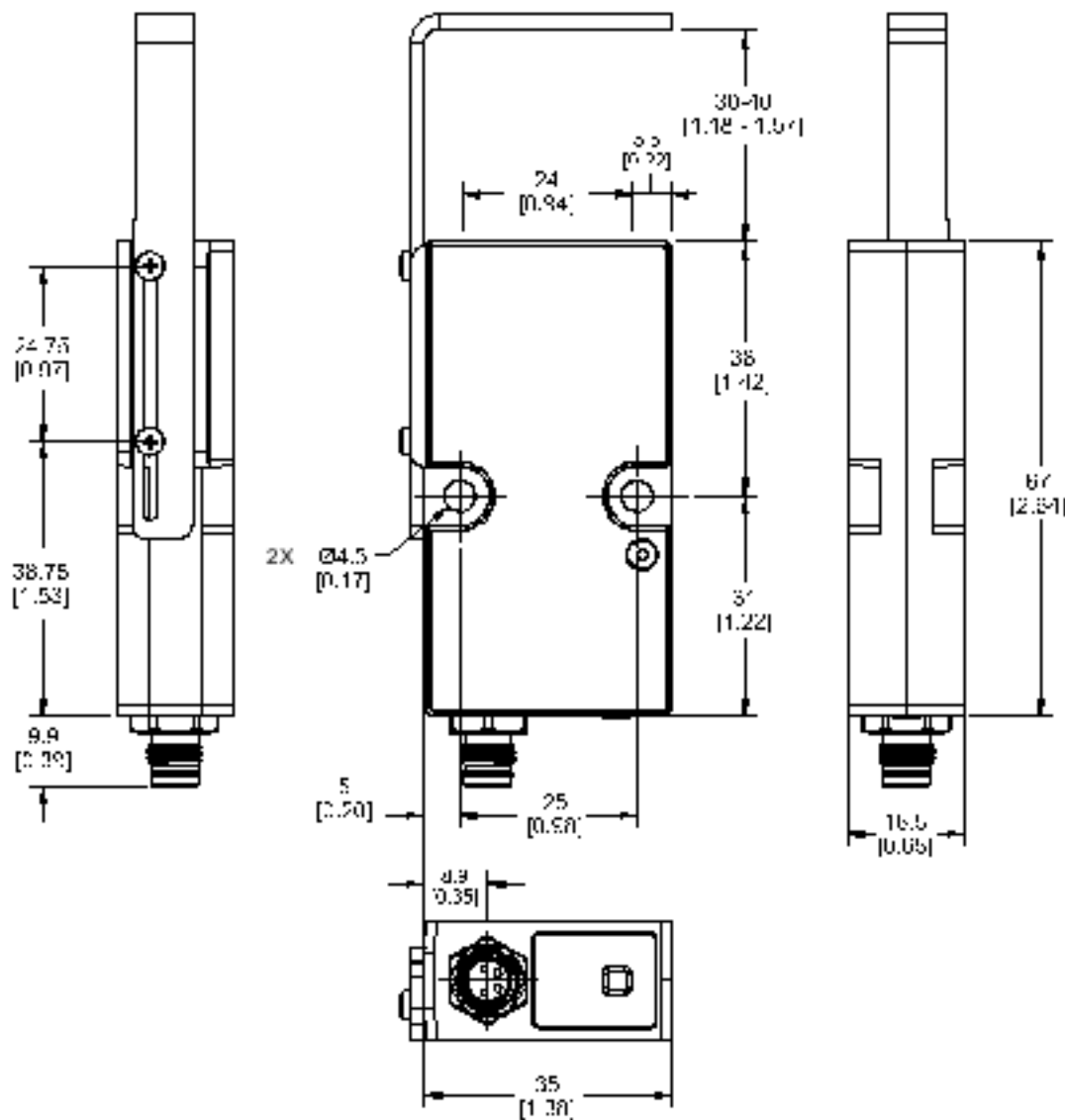

The EG24 can be ordered without the retroreflective arm or the arm can be removed for mounting flexibility. In either case, the provided retroreflective tape must be used and must be mounted 30 mm to 40 mm away from the lens to ensure optimal performance. If a replacement reflector is needed, contact Banner Engineering.

## Accessories

### Cordsets

4 Pin Snag on M8 Cordsets—Single Ended				
Model	Length	Style	Dimensions	Pinout (Female)
PKG4-2	2.03 m (6.66 ft)	Straight		
PKG4-5	5.03 m (16.5 ft)			
PKG4-10	10 m (32.9 ft)			
PKW4Z-2	2 m (6.56 ft)	Right Angle		
PKW4Z-5	5 m (16.4 ft)			

- 1 = Brown
- 2 = White
- 3 = Blue
- 4 = Black

## Banner Engineering Corp Limited Warranty

---

Banner Engineering Corp. warrants its products to be free from defects in material and workmanship for one year following the date of shipment. Banner Engineering Corp. will repair or replace, free of charge, any product of its manufacture which, at the time it is returned to the factory, is found to have been defective during the warranty period. This warranty does not cover damage or liability for misuse, abuse, or the improper application or installation of the Banner product.

THIS LIMITED WARRANTY IS EXCLUSIVE AND IN LIEU OF ALL OTHER WARRANTIES WHETHER EXPRESS OR IMPLIED (INCLUDING, WITHOUT LIMITATION, ANY WARRANTY OF MERCHANTABILITY OR FITNESS FOR A PARTICULAR PURPOSE), AND WHETHER ARISING UNDER COURSE OF PERFORMANCE, COURSE OF DEALING OR TRADE USAGE.

This Warranty is exclusive and limited to repair or, at the discretion of Banner Engineering Corp., replacement. IN NO EVENT SHALL BANNER ENGINEERING CORP. BE LIABLE TO BUYER OR ANY OTHER PERSON OR ENTITY FOR ANY EXTRA COSTS, EXPENSES, LOSSES, LOSS OF PROFITS, OR ANY INCIDENTAL, CONSEQUENTIAL OR SPECIAL DAMAGES RESULTING FROM ANY PRODUCT DEFECT OR FROM THE USE OR INABILITY TO USE THE PRODUCT, WHETHER ARISING IN CONTRACT OR WARRANTY, STATUTE, TORT, STRICT LIABILITY, NEGLIGENCE, OR OTHERWISE.

Banner Engineering Corp. reserves the right to change, modify or improve the design of the product without assuming any obligations or liabilities relating to any product previously manufactured by Banner Engineering Corp. Any misuse, abuse, or improper application or installation of this product or use of the product for personal protection applications when the product is identified as not intended for such purposes will void the product warranty. Any modifications to this product without prior express approval by Banner Engineering Corp will void the product warranties. All specifications published in this document are subject to change; Banner reserves the right to modify product specifications or update documentation at any time. Specifications and product information in English supersede that which is provided in any other language. For the most recent version of any documentation, refer to: [www.bannerengineering.com](http://www.bannerengineering.com).

For patent information, see [www.bannerengineering.com/patents](http://www.bannerengineering.com/patents).