

## R70SR Features

Sure Cross® R70SR Serial Data Radios are compact, industrial, low-power wireless communications devices used to extend the range of serial communications networks. The Serial Data Radios are available in two frequencies, 900 MHz and 2.4GHz, and are fitted with M12 quick disconnect connectors for fast deployment.

For additional information, updated documentation, and a list of accessories, refer to Banner Engineering's website, [www.bannerengineering.com](http://www.bannerengineering.com).

- RS-485 serial communication
- Star or tree network topology configuration
- DIP switches select operational modes
- Frequency Hopping Spread Spectrum (FHSS) technology ensures reliable data delivery
- Self-healing, auto-routing radio frequency network with multiple hops to extend the network's range



## R70SR Models

Models	Frequency	Transmit Power
R70SR9MQ	900 MHz ISM Band	1 Watt
R70SR2MQ	2.4 GHz ISM Band	65 mW (100 mW EIRP)

The contents of this document also apply to kits R70KSR9MQ and R70KSR2MQ. The kits each include two matched R70SRxMQ devices that have been paired together for easy configuration.

## Quick Start Guide

### Setting Up Your Data Radio Network

To set up and install your wireless Data Radio network, follow these steps:

1. Before installing your data radios, verify that your serial devices work. Connect your serial devices using a serial cable.
2. Configure the DIP switches of all devices.
3. Apply power to all devices.
4. Form the wireless network by binding the repeater and peripheral radios to the controller/primary radio.
5. Observe the LED behavior to verify the devices are communicating with each other.
6. Install your wireless sensor network components. For more details about installing your radios, refer to the [Sure Cross Installation Guide](#) (p/n 151514) downloadable from the Wireless Reference Library at [www.bannerengineering.com](http://www.bannerengineering.com).

## Buttons and LEDs

*Binding button, LEDs, and DIP switches*

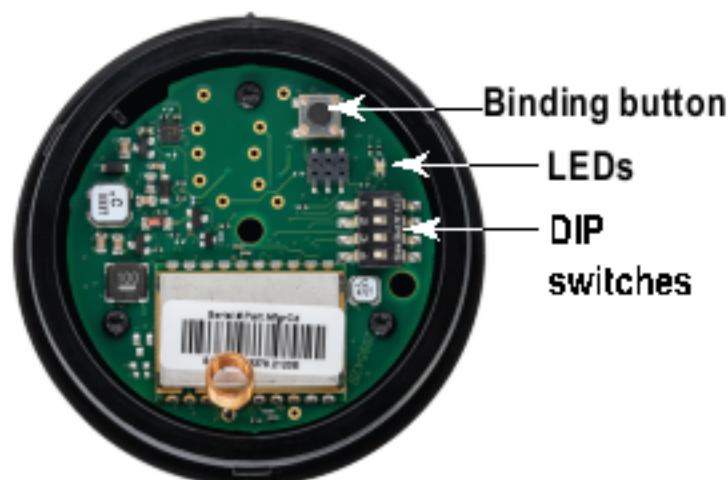

## Configure the DIP Switches

Before changing DIP switch positions, disconnect the power <sup>(1)</sup>. Any changes made to the DIP switches are not recognized until after power is cycled to the device. For parameters not set using the DIP switches, use the configuration software to make configuration changes. For parameters set using the DIP switches, the DIP switch positions override any changes made using the configuration software.

### Open the Cover

If the cover is in the locked position, the arrow on the cover is above the notch on the base. Follow these steps to unlock and remove the cover.

1. Rotate the cover counterclockwise so that the notches are aligned together.
2. Pull the top cover off.

## Serial Mode vs MultiHop Mode for R70SR Data Radios

As of early 2023, the R70SR Serial Data Radio firmware allows the radio to be configured as either a serial data radio or a MultiHop data radio that is compatible with other Banner Sure Cross MultiHop data radios. These updated R70SR serial data radios also contain an additional ID label on the device to assist with MultiHop site surveys. Ignore this label when your radio is operating in serial data radio mode. R70SR serial data radios manufactured before date code xxxx have different DIP switch configurations. Please refer to datasheet [224673](#) for the legacy R70SR model instructions.

**Serial Mode--Serial Mode** provides the simplest setup and best performance for point-to-point networks and small star networks. Serial mode is not ideal for medium to large Star or Tree topologies because the client radio broadcasts all messages and does not build a routing table. This results in slower communication, which is ideal for simple cable replacement applications. There is no need to adjust the Modbus address of connected devices, resulting in a simpler set-up process.

**MultiHop Data Radio Mode--MultiHop Data Radio mode** requires more configuration but allows for much larger Star and Tree topologies because the client radio builds a routing table to more efficiently communicate with each server device on the network. Configuring your data radio as a MultiHop radio adds the ability to perform a site survey analysis with the MultiHop Configuration Software, offers improved performance in larger Star and Tree network topologies, and adds the ability to communicate with other Sure Cross MultiHop data radios including the MultiHop DXM Wireless Controllers.

For additional information, refer to one of the following documents:

- [MultiHop Data Radio Quick Start Guide \(p/n 152653\)](#)
- [MultiHop Data Radio Instruction Manual \(p/n 151317\)](#)
- [MultiHop Register Guide \(p/n 155289\)](#)

## DIP Switch Settings for the R70SR in Serial Mode

Device Settings	Dip Switches			
	1	2	3	4
Serial Mode	Off			
Serial Routed Mode		Off		
Serial Broadcast Mode		ON		
Server Mode			OFF	OFF
Set this radio to be a client radio. For 900 MHz models, set to 1 W (30dBm) transmit power; for 2.4 GHz models the transmit power remains at 65 mW			OFF	ON
Set this radio to be a repeater radio (900 MHz or 2.4 GHz Models)			ON	OFF
Set this radio to be a server radio. For 900 MHz models, set to 250 mW (24dBm) transmit power; for 2.4 GHz models the transmit power remains at 65 mW			ON	ON

**Baud Rate and Parity**— The baud rate and parity are set to default at 19200; no parity. These settings are not configurable via the DIP switches and must be changed using AT commands. These settings must match the device wired to the radio's serial port. A faster baud rate setting may improve system response time. Changing the baud rate does NOT change the radio transmission rate. The software default also provides the ability to set custom baud rate and timing parameter settings via AT commands. For more information, see the technical note [Changing the Baud Rate and Parity on an R70SR Serial Data Radio \(p/n b\\_51173725\)](#).

**Serial Routed Mode**—Use routed messaging when using a point-to-point or point-to-point-with-repeater topology. Routing is more robust and faster than broadcast messaging. In routed mode, the radios will route serial data packets only to a single device. In general, this mode is for faster communications. If the server radios are in routed mode, they will only route serial data packets to the client radio and will only listen for serial data packets coming from the client. If the client radio is in routed mode, it will only route serial data packets to the first server radio that comes into the network. The client radio should only be in routed mode if used in a point-to-point network.

**Serial Broadcast Mode**—Broadcast mode allows for more flexible radio layouts and is used in the star and MultiHop tree topologies. These topologies are much more flexible but they are slower. When using broadcast mode, a small percentage of data packets will not be reach

<sup>(1)</sup> For devices powered by batteries integrated into the housing, triple-click button 2, then double-click button 2 to reset the device without removing the battery.

their destination. Broadcast mode requires the application layer to automatically retry packets that time out. In networks with multiple server, the client radio must use broadcast mode, but the server radios can be set to use routing mode to route their data packets back to the client radio. In broadcast mode, the radios route serial data packets to all devices in the network. In general, this mode will have slower communication speeds but will allow for much more system flexibility. If the servers and repeaters are in broadcast mode, they route serial data packets to all other devices and listen to serial data packets coming from all devices. If the client radio is in broadcast mode, it routes serial data packets to all servers and repeaters and listens to serial data packets coming from all devices.

**Transmit Power Levels**—The 900 MHz radios transmit at 1 Watt (30 dBm) or 250 mW (24 dBm). The 250 mW mode reduces the radio's range, which can help avoid cross talk in areas with multiple systems. For 2.4 GHz models, this DIP switch is disabled. The transmit power for 2.4 GHz is fixed at about 65 mW EIRP (18 dBm).

## Network Topologies in Serial Mode

**Cable Replacement Configuration for Point-to-Point Networks**--In this simple cable replacement application, the radio system knows all data originating at one end must be transmitted to the other end. This allows the radio system to automatically correct for transmission problems and it also provides the greatest throughput. This is the fastest configuration.

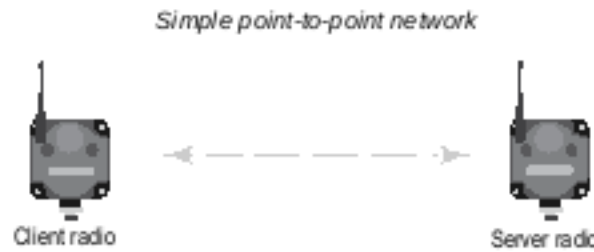

Device Settings	DIP Switches			
	1	2	3	4
Client configuration route to a server	Off	Off	Off	On
Server configuration route to the client	Off	Off	Off	Off

**Cable Replacement with a Repeater**--In this simple cable replacement application with a repeater, the radio system still knows all data originating at one end must be transmitted to the other end. In this application, there are no serial devices connected to the repeater(s). The system still corrects for transmission problems, but it takes time to repeat the message. The network delay is double that of a system with no repeater.

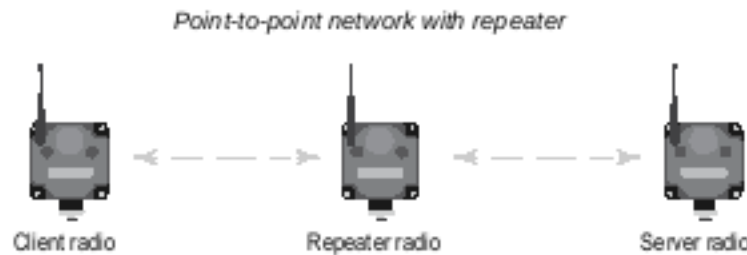

Device Settings	DIP Switches			
	1	2	3	4
Client configuration route to a server	Off	Off	Off	On
Repeater configuration	Off	On	On	Off
Server configuration route to the client	Off	Off	Off	Off

**Serial Broadcast Mode Configuration with a Star Network**--In this more complex star topology, the client radio at the center of the network can communicate to many server radios. A common example would be a PLC at the center communicating with many remote I/O systems. The star topology is slower than a point-to-point network, but faster than a tree network.

Serial broadcast mode configuration with a star network

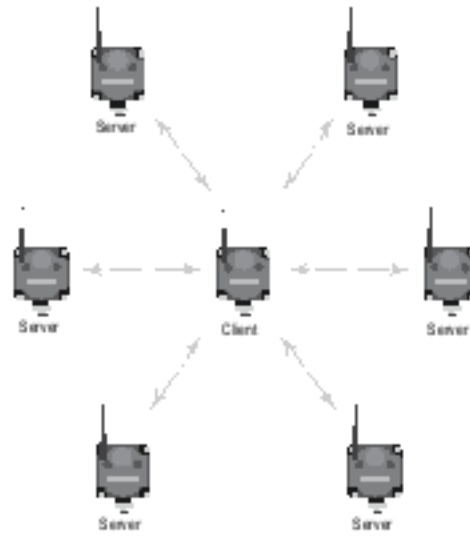

Device Settings	DIP Switches			
	1	2	3	4
Client configuration to broadcast to all devices	Off	On	Off	On
Server configuration to route to the client	Off	Off	Off	Off

Serial Broadcast Mode Configuration with a Tree Network--A tree network using multiple radios is very flexible; many repeaters and servers can be combined to cover vast areas and get around hills or buildings. In the other networks, the wireless "hops" are minimized. In this system, you can "hop" as much as you need to, but the trade-off is speed. This is the slowest of the network layouts. For larger tree networks, we recommend avoiding serial broadcast mode and switching the radios to MultiHop Data Radio mode.

Serial broadcast mode configuration with a tree network

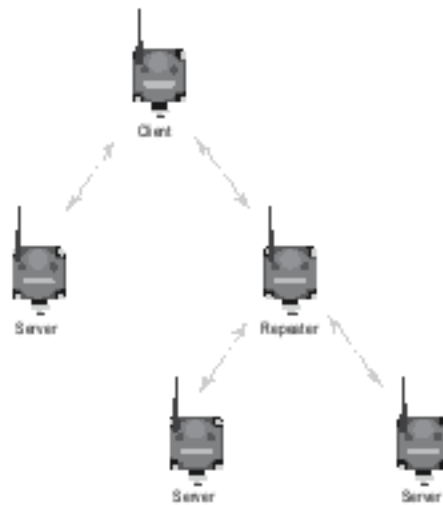

Device Settings	DIP Switches			
	1	2	3	4
Client configuration to broadcast to all devices	Off	On	Off	On
Repeater configuration to broadcast to all devices	Off	On	On	Off
Server configuration to broadcast to all devices	Off	On	Off	Off

**IMPORTANT:** Star and tree topologies in serial mode use a Broadcast radio technique. Broadcasting allows for many radios and larger, complex systems but also introduces a small chance that a data packet can be lost. These network topologies require the control system to automatically resend missing data packets. Most control protocols (like Modbus) will work fine. Other serial stream-based protocols may not be as tolerant and should only be used with point-to-point topologies.

### DIP Switch Settings for the R70SR in MultiHop Mode

Device Settings	DIP Switches			
	1	2	3	4
MultiHop Data Radio Mode	ON			

Continued on page 5

Continued from page 4

Device Settings	DIP Switches			
	1	2	3	4
Power/Radio Selection - 900 MHz models are set to 1 W (30dBm) transmit power; 2.4 GHz models are set to GFSK Radio modulation (transmit power remains at 65 mW)		OFF		
Power/Radio Selection - 900 MHz models are set to 250 mW (24dBm) transmit power; 2.4 GHz models are set to FLRC Radio modulation (transmit power remains at 65 mW)		ON		
Set this radio to be a MultiHop server radio			OFF	OFF
Set this radio to be a MultiHop client radio			OFF	ON
Set this radio to be a MultiHop repeater radio			ON	OFF
Reserved			ON	ON

## Network Topologies in MultiHop Mode

**Cable Replacement Configuration for Point-to-Point Networks**--In this simple cable replacement application, the radio system knows all data originating at one end must be transmitted to the other end. This allows the radio system to automatically correct for transmission problems and it also provides the greatest throughput. This is the fastest configuration.

*Simple cable replacement configuration for a point-to-point network*



Device Settings	DIP Switches			
	1	2	3	4
Client configuration	On	Off	Off	On
Server configuration	On	Off	Off	Off

**Cable Replacement Configuration for with Repeaters**--In this simple cable replacement application with a repeater radio, the radio system still knows all data originating at one end must be transmitted to the other end. In this application, no serial devices are connected to the repeater(s). The system still corrects for transmission problems, but it takes time to repeat the message. The network delay is double that of a system with no repeater.

*Simple cable replacement configuration for a point-to-point network with a repeater*



Device Settings	DIP Switches			
	1	2	3	4
Client configuration	On	Off	Off	On
Repeater configuration	On	Off	On	Off
Server configuration	On	Off	Off	Off

**MultiHop Mode (Star Network)**--In this more complex star topology, the client radio at the center of the network can communicate with many server radios. A common example would be a PLC at the center communicating with many remote I/O systems. The star topology is slower than a point-to-point network but faster than a tree network.

MultiHop mode star network

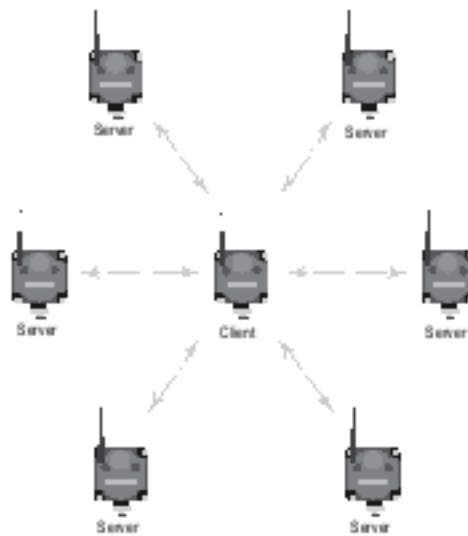

Device Settings	DIP Switches			
	1	2	3	4
Client configuration	On	Off	Off	On
Server configuration	On	Off	Off	Off

MultiHop Mode with a Tree Network Configuration—A tree network using MultiHop radios is the most powerful wireless system possible; many repeaters and server can be combined to cover vast areas and get around hills or buildings. In the other networks, the wireless "hops" are minimized. In this system, you can "hop" as much as you need to. In MultiHop mode, there may be some speed tradeoffs, but it is still significantly faster and more reliable than a Tree Topology in Serial Mode.

MultiHop mode with a tree network

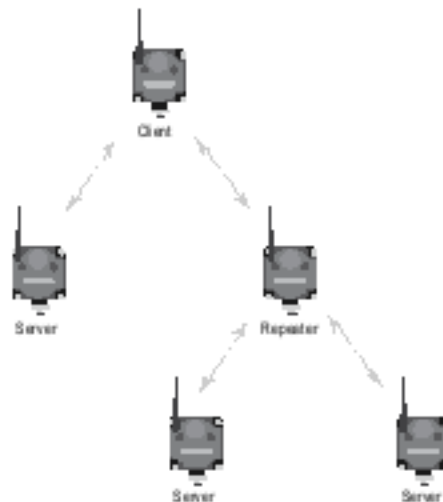

Device Settings	DIP Switches			
	1	2	3	4
Client configuration	On	Off	Off	On
Repeater configuration	On	Off	On	Off
Server configuration	On	Off	Off	Off

Packet Routing in MultiHop Data Radio Mode—In MultiHop Data Radio mode, the client radio first discovers all connected Modbus server in the network, then uses the Modbus ID contained in the incoming Modbus message to wirelessly route the packet only to the radio attached to the target Modbus server. The packet is then passed via the radio's serial interface to the Modbus device where it is processed. This is entirely transparent to the user. Direct packet-by-packet routing offers an advantage over broadcast addressing with MultiHop paths because each hop in the path can be retried independently in the event of a packet error. This results in significantly more reliable packet delivery over MultiHop paths. Modbus IDs 01 through 10 are reserved for server directly connected to the host (local I/O). As such, polling messages addressed to these devices are not relayed over the wireless link. Use Modbus IDs 11 through 60 for remote Modbus server — devices serially connected to an R70 Server or Repeater — allowing a maximum of 50 attached devices.

## Apply Power to the R70SR

The R70SR Serial Data Radio is fitted with a 5-pin M12 connector for fast installations. Use straight splitter cordsets to connect multiple devices and power to the R70SR Serial Radio. For a list of splitter and cordset options, see ["R70SR Accessories" on page 10](#).

5-pin M12 Male Connector	Pin	Wire Color	Wiring Description
	1	Brown (bn)	10 to 30 V DC
	2	White (wh)	RS-485 / D1 / B / +
	3	Blue (bu)	DC common (GND)
	4	Black (bk)	RS-485 / D0 / A / -
	5	Gray (gy)	No connection

## Bind the R70SR Serial Data Radio to Form a Network

To create your network, bind the R70SR to the designated server radio.

Verify your radio DIP Switches and connected device Modbus IDs are set according to ["Configure the DIP Switches" on page 2](#).

Binding the serial data radios ensures all radios within a network communicate only with the other radios within the same network. The serial data primary radio automatically generates a unique binding code when it enters binding mode. This code is transmitted to all radios within range that are also in binding mode. After a repeater/server is bound, the repeater/server radio accepts data only from the client radio to which it is bound. The binding code defines the network, and all radios within a network must use the same binding code.

1. Apply power to all radios and place the R70SR radio at least two meters away from the client radio.
2. Remove the cover. See ["Open the Cover" on page 2](#).
3. On the client radio: Triple-click the binding button to put the client radio into binding mode. Both LEDs flash red.
4. On the R70SR: Triple-click the binding button to put the R70SR into binding mode. The radio enters binding mode and searches for any client radio in binding mode. While searching for the client radio, the two red LEDs flash alternately. When the radio finds the client radio and is bound, both red LEDs are solid for four seconds, then both red LEDs flash simultaneously four times.
5. Re-install the R70SR's cover.
6. Repeat steps 3 through 5 for as many radios as are needed for your network.
7. On the client radio: After all radios are bound, double-click the binding button to exit binding mode on the client. The network begins to form after the client data radio exits binding mode.
8. On the client radio: Re-install the cover to protect the button and radio board.

### Child (Server) Radios Synchronize to the Parent (Client) Radios

The synchronization process enables a Sure Cross radio to join a wireless network formed by a client radio. A simple point-to-point network with one client radio and one server radio synchronizes quickly after power up; larger MultiHop networks may take a few minutes to synchronize. First, all radios within range of the client data radio wirelessly synchronize to the client radio. These radios may be server or repeater radios.

After repeater radios are synchronized to the client radio, any radios that are not in sync with the client but can "hear" the repeater radio will synchronize to the repeater radios. Each repeater "family" that forms a wireless network path creates another layer of synchronization process. When testing the devices before installation, verify the radios are at least two meters apart or the communications may fail.

## MultiHop Configuration Software

Use Banner's MultiHop Configuration Software to view your MultiHop radio network and configure the radio and its I/O.

MultiHop Configuration Software Network and Device Overview screen

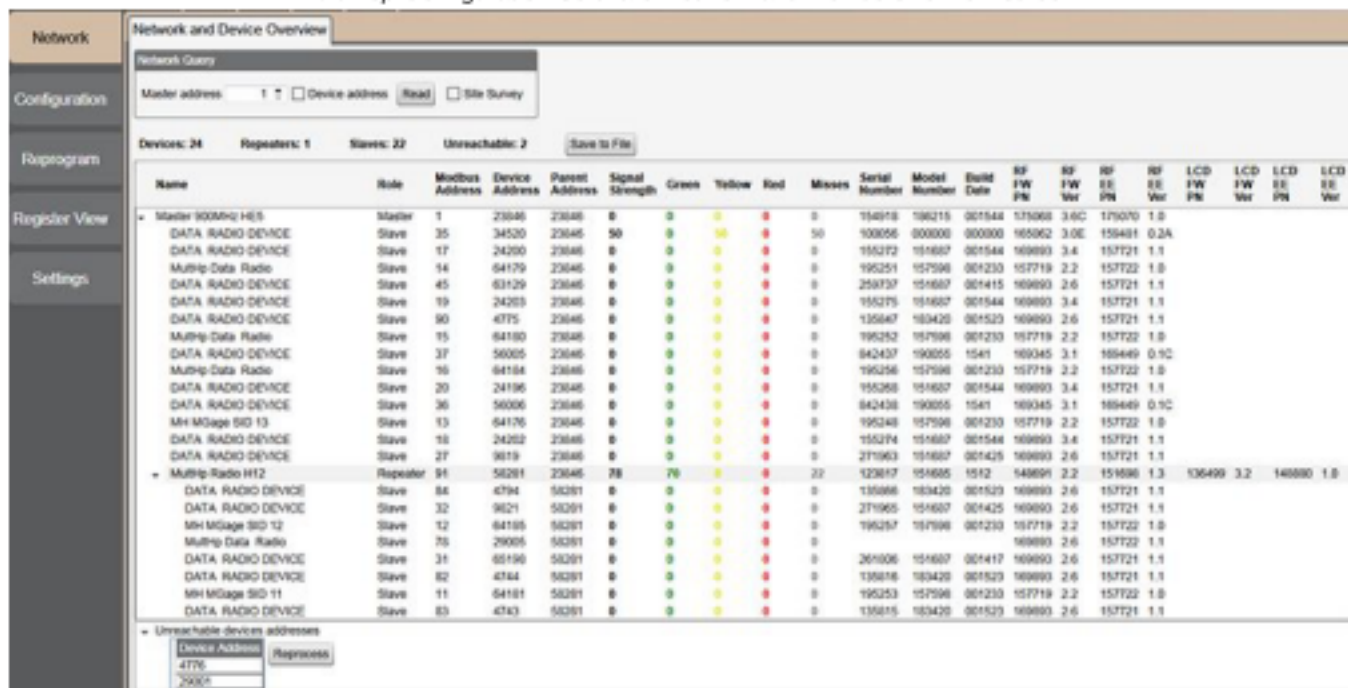

The software connects to a MultiHop client radio using one of four methods.

## R70SR SNAP SIGNAL™ SerialData Radio

- Serial; using a USB to RS-485 (for RS-485 radios) or a USB to RS-232 (for RS-232 radios) converter cable.
- Modbus TCP; using an Ethernet connection to an Ethernet radio client.
- Serial DXM; using a USB cable to a DXM Controller to access a MultiHop client radio.
- TCP DXM; using an Ethernet connection to a DXM Controller to access a MultiHop client radio.

Banner recommends using BWA-UCT-900, an RS-485 to USB adapter cable with a wall plug that can power your radio while you configure it. The adapter cable is not required when connecting to a DXM Controller.

Download the most recent software revision from the Wireless Reference Library on Banner Engineering's website: [www.bannerengineering.com](http://www.bannerengineering.com).

## Client Radio LED Behavior

All bound radios set to operate as client radios follow this LED behavior after powering up.

Process Steps	Response	LED 1	LED 2
1	Apply power to the client radio	-	Solid amber
2	The client radio enters RUN mode.	Flashes green	-
	Data packets begin transmitting between the client and its children radios.	-	Flashes amber
	In binding mode	Flashes red	Flashes red

## Server Radio LED Behavior

All bound radios set to server or repeater modes follow this LED behavior after powering up.

Process Steps	Response	LED 1	LED 2
1	Apply power to the radio	-	Solid amber (briefly)
2	The server/repeater searches for a parent device.	Flashes red	-
3	A parent device is detected. The client/repeater searches for other parent radios within range.	Solid red	-
4	The server/repeater selects a suitable parent.	-	Solid amber
5	The server/repeater attempts to synchronize to the selected parent.	-	Solid red
6	The server/repeater is synchronized to the parent.	Flashes green	-
7	The server/repeater enters RUN mode.	Solid green, then flashes green	
	Data packets begin transmitting between the server/repeater and its parent radio.	-	Flashes amber
	In binding mode	Flashes red	Flashes red

## Installing Your Sure Cross® Radios

Please refer to one of these instruction manuals to install your wireless network components.

- DX80 Performance Wireless I/O Network Instruction Manual: [132607](#)
- MultiHop Data Radio Instruction Manual: [151317](#)

## R70SR Specifications

### Radio Range

- 900 MHz (500 mW): Up to 1.6 km (1 mile) (internal antenna)
- 2.4 GHz: Up to 1000 m (3280 ft) with line of sight (internal antenna)

### Antenna Minimum Separation Distance

- 900 MHz (500 mW): 4.57 m (15 ft) with the supplied 2 dB antenna
- 2.4 GHz, 65 mW: 0.3 m (1 ft)

### Radio Transmit Power

- 900 MHz Conducted: 27 dBm (500 mW); EIRP with the supplied 4 dB antenna: 31 dBm (1260 mW)
- 2.4 GHz Conducted: < 18 dBm (65 mW); EIRP with the supplied 2 dB antenna: < 20 dBm (100 mW)

### Spread Spectrum Technology

- FHSS (Frequency Hopping Spread Spectrum)

### Communication Protocols

- Modbus® RTU, Modbus/TCP, EtherNet/IP™
- EtherNet/IP™ is a trademark of ODVA, Inc. Modbus® is a registered trademark of Schneider Electric USA, Inc.

### Security Protocols

- TLS, SSL, HTTPS

### 900 MHz Compliance (RM7023 Radio Module)

- Radio module is indicated by the product label marking
- Contains FCC ID: UE3RM7023: FCC Part 15, Subpart C, 15.247
- Contains IC: 7044A-RM7023



**2.4 GHz Compliance (SX243 Radio Module)**

Radio module is indicated by the product label marking  
 Contains FCC ID: UE3SX243: FCC Part 15, Subpart C, 15.247  
 Radio Equipment Directive (RED) 2014/53/EU  
 ETSI/EN: EN 300 328 V2.2.2 (2019-07) [RED HarmStds]  
 Contains IC: 7044A-SX243  
 ANATEL: 03737-22-04042

**Radio Data Transfer Rate**

900 MHz: 300 kbps  
 2.4 GHz: 250 kbps

**Supply Voltage**

10 V DC to 30 V DC (Outside the USA: 12 V DC to 24 V DC, ± 10%)  
 For European applications, power this device from a Limited Power Source as defined in EN 60950-1.

**Average Current for 900 MHz Radios (1500 byte packets at 50 ms intervals)**

Client Mode: 0.12 A at 12 V; 0.06 A at 24 V  
 Server Mode: 0.03 A at 12 V; 0.017 A at 24 V

**Average Current for 2.4 GHz Radios (1500 byte packets at 50 ms intervals)**

Client Mode: 0.035 A at 12 V; 0.02 A at 24 V  
 Server Mode: 0.022 A at 12 V; 0.014 A at 24 V

**Interface**

Two bi-color LED indicators  
 One button (under the small round cover)

**Construction**

Base: Black polycarbonate  
 Cover: Translucent gray polycarbonate

**Operating Conditions**

-40 °C to +85 °C (-40 °F to +185 °F)  
 95% maximum relative humidity (non-condensing)  
 Radiated Immunity: 10 V/m (EN 61000-4-3)  
 Operating the devices at the maximum operating conditions for extended periods can shorten the life of the device.

**Environmental Ratings**

IP65  
 For installation and waterproofing instructions, go to [www.bannerengineering.com](http://www.bannerengineering.com) and search for the complete instruction manual

**Shock and Vibration**

All models meet IEC 60068-2-6 and IEC 60068-2-27 testing criteria  
 Shock: 30G 11 ms duration, half sine wave per IEC 60068-2-27  
 Vibration: 10 Hz to 55 Hz, 0.5 mm peak-to-peak amplitude per IEC 60068-2-6

**Certifications**

Banner Engineering BV  
 Park Lane, Culliganlaan 2F bus 3  
 1831 Diegem, BELGIUM



Turck Banner LTD Blerheim House  
 Blerheim Court  
 Wickford, Essex SS11 8YT  
 GREAT BRITAIN

(CE/UKCA approval only applies to 2.4 GHz models)



CCAK23Y20040T2

警語低功率電波輻射性電機管理辦法第十二條經型式認證合格之低功率射頻電機，非經許可，公司、商號或使用者均不得擅自變更頻率、加大功率或變更原設計之特性及功能。第十四條低功率射頻電機之使用不得影響飛航安全及干擾合法通信；經發現有干擾現象時，應立即停用，並改善至無干擾時方得繼續使用。前項合法通信，指依電信規定作業之無線電信。低功率射頻電機須忍受合法通信或工業、科學及醫療用電波輻射性電機設備之干擾。

**FCC Part 15 Class A for Intentional Radiators**

This equipment has been tested and found to comply with the limits for a Class A digital device, pursuant to Part 15 of the FCC Rules. These limits are designed to provide reasonable protection against harmful interference when the equipment is operated in a commercial environment. This equipment generates, uses, and can radiate radio frequency energy and, if not installed and used in accordance with the instruction manual, may cause harmful interference to radio communications. Operation of this equipment in a residential area is likely to cause harmful interference in which case the user will be required to correct the interference at his own expense.

(Part 15.21) Any changes or modifications not expressly approved by the party responsible for compliance could void the user's authority to operate this equipment.

**Industry Canada Statement for Intentional Radiators**

This device complies with licence exempt transmitter(s)/receiver(s) that comply with Innovation, Science and Economic Development Canada's licence exempt RSS(s). Operation is subject to the following two conditions:

1. This device may not cause interference.
2. This device must accept any interference, including interference that may cause undesired operation of the device.

Cet appareil convient des émetteurs/récepteurs exempts de licence conformes à la norme Innovation, Sciences et Développement économique Canada. L'exploitation est autorisée aux deux conditions suivantes:

1. L'appareil ne doit pas produire de brouillage.
2. L'utilisateur de l'appareil doit accepter tout brouillage radioélectrique subi, même si le brouillage est susceptible d'en compromettre le fonctionnement.

## R70SR Dimensions

All measurements are listed in millimeters, unless noted otherwise.

Dimensions for the R70SR

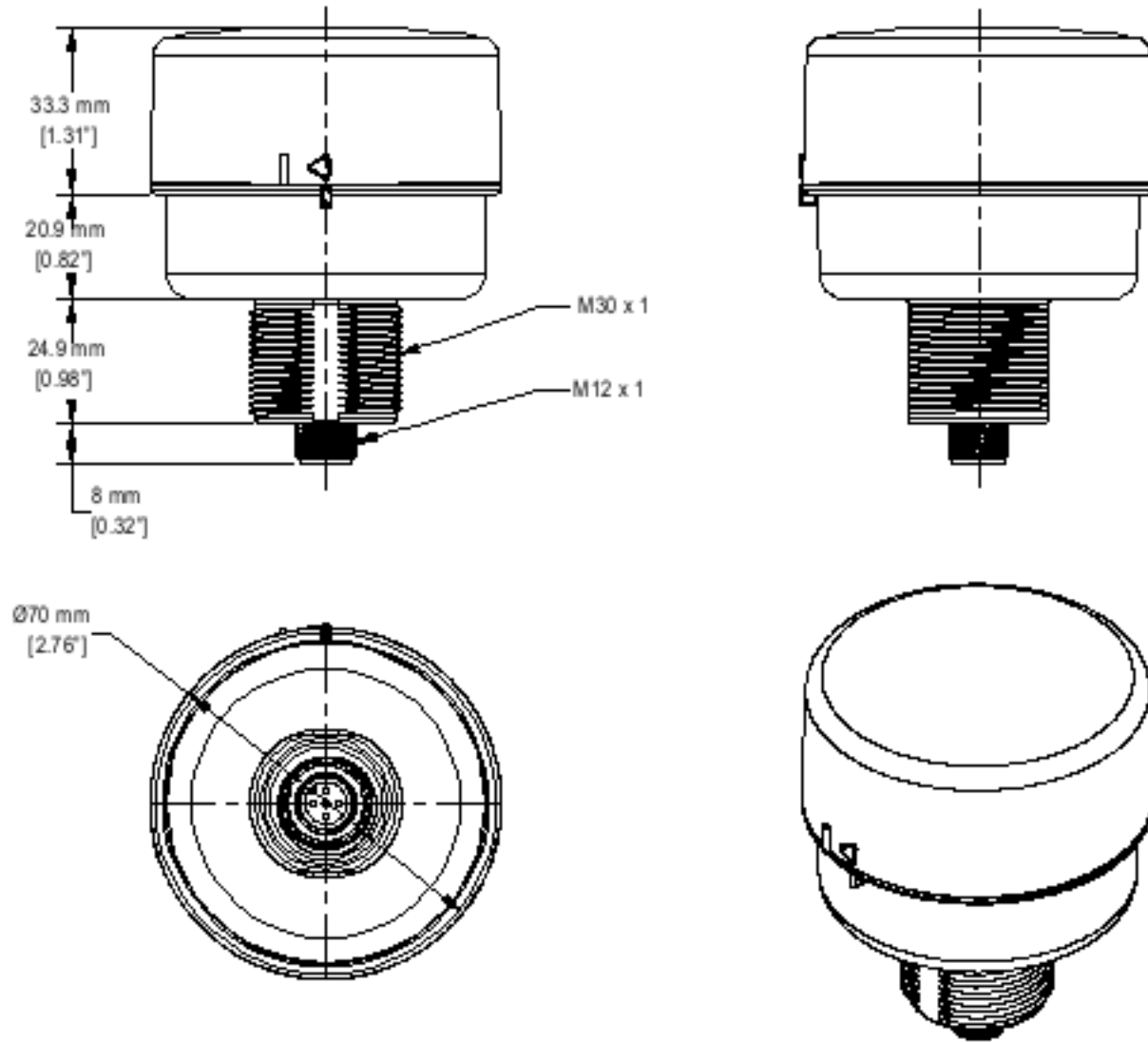

## R70SR Accessories

4 Pin Threaded M12 Cords— Single Ended				
Model	Length	Style	Dimensions	Pinout (Female)
MQDC-403	1 m (3.28 ft)	Straight		
MQDC-408	2 m (6.56 ft)			
MQDC-410	3 m (9.8 ft)			
MQDC-415	5 m (16.4 ft)			
MQDC-430	9 m (29.5 ft)			
MQDC-450	15 m (49.2 ft)			

4 Pin Threaded M12 Cords— Single Ended				
Model	Length	Style	Dimensions	Pinout (Female)
MQDC-408RA	2 m (6.56 ft)	Right-Angle		
MQDC-415RA	5 m (16.4 ft)			
MQDC-430RA	9 m (29.5 ft)			
MQDC-450RA	15 m (49.2 ft)			

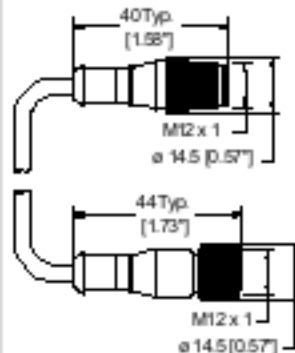
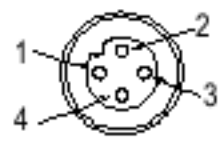
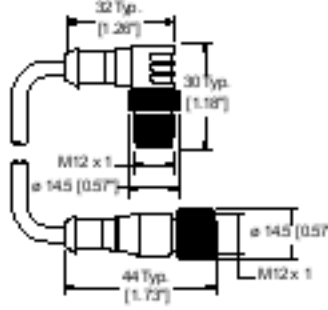
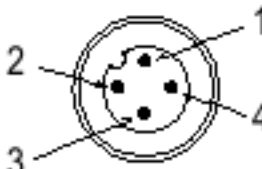
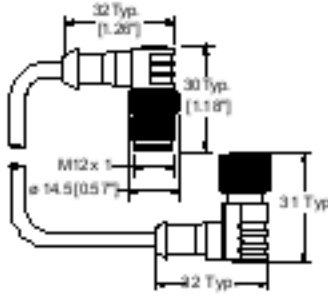
4 Pin Threaded M12 Cordsets—Double Ended				
Model	Length	Style	Dimensions	Pinout
MQDEC-401SS	0.31 m (1 ft)	Male Straight/Female Straight		<p>Female</p> 
MQDEC-403SS	0.91 m (2.99 ft)			
MQDEC-406SS	1.83 m (6 ft)			
MQDEC-412SS	3.66 m (12 ft)			
MQDEC-420SS	6.10 m (20 ft)			
MQDEC-430SS	9.14 m (30.2 ft)			
MQDEC-450SS	15.2 m (49.9 ft)			
MQDEC-403RS	0.91 m (2.99 ft)	Male Right-Angle/Female Straight		<p>Male</p>  <p>1 = Brown 2 = White 3 = Blue 4 = Black</p>
MQDEC-406RS	1.83 m (6 ft)			
MQDEC-412RS	3.66 m (12 ft)			
MQDEC-420RS	6.10 m (20 ft)			
MQDEC-430RS	9.14 m (30.2 ft)			
MQDEC-450RS	15.2 m (49.9 ft)			
MQDEC-403RR	0.9 m (2.9 ft)	Male Right-Angle/Female Right-Angle		
MQDEC-406RR	1.8 m (5.9 ft)			
MQDEC-412RR	3.6 m (11.8 ft)			
MQDEC-420RR	6.1 m (20 ft)			

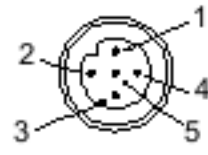
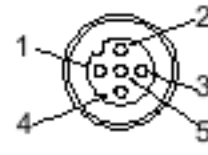
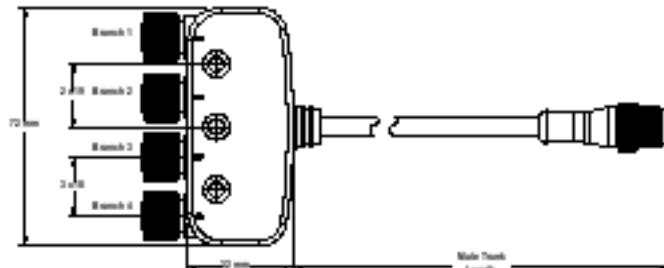
5 Pin Threaded M12 Splitter Cordset with Right Junction—Double Ended				
Model	Trunk (Male)	Branches (Female)	Pinout (Male)	Pinout (Female)
CSB4-M1251M1250	0.3 m (0.98 ft)	Four (no cable)		
			<p>1 = Brown 2 = White 3 = Blue</p>	<p>4 = Black 5 = Gray</p>

5-Pin Threaded M12 Splitter Tee				
Model	Description		Pinout (Male)	Pinout (Female)
CSB-M 1250M1250-T	Female trunk, 1 female branch, 1 male branch		 <p>1 = Brown 2 = White 3 = Blue</p>	 <p>4 = Black 5 = Green/Yellow</p>

<p>LMB30LP</p> <ul style="list-style-type: none"> <li>• Low profile</li> <li>• 30 mm mounting hole</li> <li>• 300 series stainless steel</li> </ul>	
<p>WC-R70 Washdown Cover</p> <ul style="list-style-type: none"> <li>• FDA-grade silicone</li> <li>• Fits R70 data radios</li> <li>• IP67 and IP69K rated</li> </ul>	
<p>PSW-24-1</p> <ul style="list-style-type: none"> <li>• 24 V DC, 1 A Class 2 UL Listed power supply</li> <li>• 100 V AC to 240 V AC 50/60 Hz input</li> <li>• 2 m (6.5 ft) PVC cable with M12 quick disconnect</li> <li>• Includes Type A (US, Canada, Japan, Puerto Rico, Taiwan), Type C (Germany, France, South Korea, Netherlands, Poland, Spain, Turkey), Type G (United Kingdom, Ireland, Singapore, Vietnam), and Type I (China, Australia, New Zealand) AC detachable input plugs</li> </ul>	

## Warnings



**WARNING:**

- Do not use this device for personnel protection
- Using this device for personnel protection could result in serious injury or death.
- This device does not include the self-checking redundant circuitry necessary to allow its use in personnel safety applications. A device failure or malfunction can cause either an energized (on) or de-energized (off) output condition.

**IMPORTANT:** Please download the complete R70SR Snap Signal Serial Data Radio technical documentation, available in multiple languages, from [www.banner-engineering.com](http://www.banner-engineering.com) for details on the proper use, applications, warnings, and installation instructions of this device.

**IMPORTANT:** Por favor, descargue desde [www.banner-engineering.com](http://www.banner-engineering.com) toda la documentación técnica de los R70SR Snap Signal Serial Data Radio, disponible en múltiples idiomas, para detalles de uso adecuado, aplicaciones, advertencias, y las instrucciones de instalación de estos dispositivos.

**IMPORTANT:** Veuillez télécharger la documentation technique complète des R70SR Snap Signal Serial Data Radio sur notre site [www.banner-engineering.com](http://www.banner-engineering.com) pour les détails sur leur utilisation correcte, les applications, les règles de sécurité et les instructions de montage.

Install and properly ground a qualified surge suppressor when installing a remote antenna system. Remote antenna configurations installed without surge suppressors invalidate the manufacturer's warranty. Keep the ground wire as short as possible and make all ground connections to a single-point ground system to ensure no ground loops are created. No surge suppressor can absorb all lightning strikes; do not touch the Sure Cross® device or any equipment connected to the Sure Cross® device during a thunderstorm.

Expanding Sure Cross® Radios. It is our intent to fully comply with all national and regional regulations regarding radio frequency emissions. Customers who want to re-export this product to a country other than that to which it was sold must ensure the device is approved in the destination country. The Sure Cross wireless products were certified for use in these countries using the antenna that ships with the product. When using other antennas, verify you are not exceeding the transmit power levels allowed by local governing agencies. This device has been designed to operate with the antennas listed on Banner Engineering's website and having a maximum gain of 9 dBi. Antennas not included in this list or having a gain greater than 9 dBi are strictly prohibited for use with this device. The required antenna impedance is 50 ohms. To reduce potential radio interference to other users, the antenna type and its gain should be so chosen such that the equivalent isotropically radiated power (EIRP) is not more than that permitted for successful communication. Consult with Banner Engineering Corp. if the destination country is not on this list.

**IMPORTANT:**

- Never operate a radio without connecting an antenna
- Operating radios without an antenna connected will damage the radio circuitry.
- To avoid damaging the radio circuitry, never apply power to a Sure Cross® Performance or Sure Cross® Multi-Hop radio without an antenna connected.

**IMPORTANT:**

- Electrostatic discharge (ESD) sensitive device
- ESD can damage the device. Damage from inappropriate handling is not covered by warranty.
- Use proper handling procedures to prevent ESD damage. Proper handling procedures include leaving devices in their anti-static packaging until ready for use; wearing anti-static wrist straps; and assembling units on a grounded, static-dissipative surface.

## Banner Engineering Corp Limited Warranty

Banner Engineering Corp. warrants its products to be free from defects in material and workmanship for one year following the date of shipment. Banner Engineering Corp. will repair or replace, free of charge, any product of its manufacture which, at the time it is returned to the factory, is found to have been defective during the warranty period. This warranty does not cover damage or liability for misuse, abuse, or the improper application or installation of the Banner product.

THIS LIMITED WARRANTY IS EXCLUSIVE AND IN LIEU OF ALL OTHER WARRANTIES WHETHER EXPRESS OR IMPLIED (INCLUDING, WITHOUT LIMITATION, ANY WARRANTY OF MERCHANTABILITY OR FITNESS FOR A PARTICULAR PURPOSE), AND WHETHER ARISING UNDER COURSE OF PERFORMANCE, COURSE OF DEALING OR TRADE USAGE.

This Warranty is exclusive and limited to repair or, at the discretion of Banner Engineering Corp., replacement. IN NO EVENT SHALL BANNER ENGINEERING CORP. BE LIABLE TO BUYER OR ANY OTHER PERSON OR ENTITY FOR ANY EXTRA COSTS, EXPENSES, LOSSES, LOSS OF PROFITS, OR ANY INCIDENTAL, CONSEQUENTIAL OR SPECIAL DAMAGES RESULTING FROM ANY PRODUCT DEFECT OR FROM THE USE OR INABILITY TO USE THE PRODUCT, WHETHER ARISING IN CONTRACT OR WARRANTY, STATUTE, TORT, STRICT LIABILITY, NEGLIGENCE, OR OTHERWISE.

Banner Engineering Corp. reserves the right to change, modify or improve the design of the product without assuming any obligations or liabilities relating to any product previously manufactured by Banner Engineering Corp. Any misuse, abuse, or improper application or installation of this product or use of the product for personal protection applications when the product is identified as not intended for such purposes will void the product warranty. Any modifications to this product without prior express approval by Banner Engineering Corp will void the product warranties. All specifications published in this document are subject to change; Banner reserves the right to modify product specifications or update documentation at any time. Specifications and product information in English supersede that which is provided in any other language. For the most recent version of any documentation, refer to: [www.bannerengineering.com](http://www.bannerengineering.com).

For patent information, see [www.bannerengineering.com/patents](http://www.bannerengineering.com/patents).

Document title: R70SR SNAP SIGNAL™ Serial Data Radio

Part number: 233275

Revision: C

Original Instructions

© Banner Engineering Corp. All rights reserved.

