

Features

	<ul style="list-style-type: none"> • Rugged, cost-effective, and easy-to-install Andon Control Box • Integral four or five capacitive touch button controller with programmable LEDs and discrete outputs • Programmable using Banner's Pro Editor software and Pro Converter Cable • Two M12 connectors for added Andon application flexibility and easy installation • Up to five discrete outputs available to pass up to a total of 4 amps
--	---

LCA130T Models

Model Name	Activation Method	Number of Touch Buttons	Frequency	Connector
LCA130T4DXN2Q	Touch	4 Buttons	2.4 GHz ISM Band	Integral 4-pin M12 male input quick-disconnect connector and 5-pin M12 female output quick-disconnect connector
LCA130T4DXN9Q			900 MHz ISM Band	
LCA130T5DXN2Q		5 Buttons	2.4 GHz ISM Band	Integral 4-pin M12 male input quick-disconnect connector and 8-pin M12 female output quick-disconnect connector
LCA130T5DXN9Q			900 MHz ISM Band	

LCA130T Switch Diagram

Touch, or touch and hold, one or more of the buttons to activate a programmed color and animation function.

Input Pinout - All Models

4-Pin M12 Male Connector	Pin	Wire Color	Wiring Description
	1	Brown (bn)	18 V DC to 30 V DC
	2	White (wh)	Use to configure with the Pro Editor Configuration software
	3	Blue (bu)	DC common (GND)
	4	Black (bk)	Not Used

Output Pinout - 5-Button Switch Control

5-Button LCA130T	8-pin M12 Female Connector	Pin	Description
		1	Button 3
		2	Button 4
		3	Not used
		4	Button 1
		5	Button 2
		6	Button 5
		7	DC common (GND)
		8	Not used

Output Pinout - 4-Button Switch Control

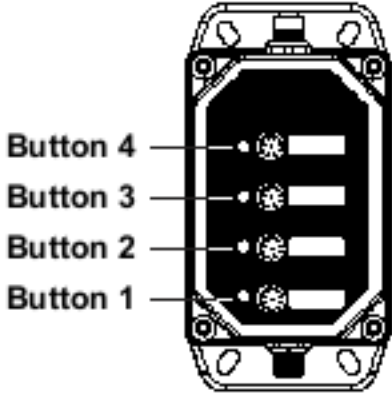
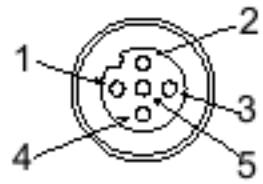
4-Button LCA130T	5-pin M12 Female Connector	Pin	Description
		1	Button 2
		2	Button 3
		3	DC common (GND)
		4	Button 1
		5	Button 4

Configuration Instructions

Pro Editor



Use Banner's Pro Editor software and Pro Converter Cable to create custom configurations by selecting different colors, flash patterns, and animations. For more information visit www.bannerengineering.com/proeditor.

LCA130T DIP Switches

Before applying power to the device, set the radio's DIP switches.

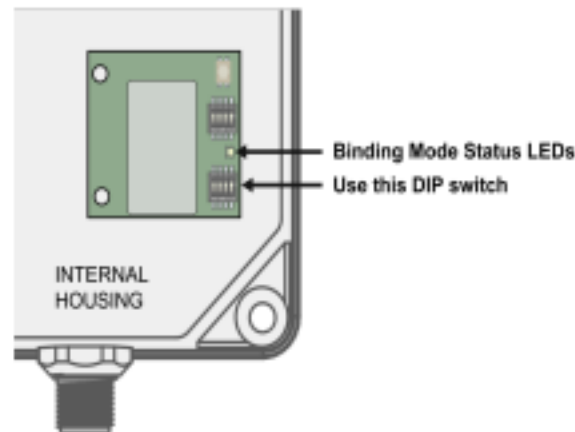

Device Settings ⁽¹⁾	DIP Switches			
	1 ⁽²⁾	2	3	4
Transmit Power Level: 500 mW (default setting)	OFF			
Transmit Power Level: 250 mW	ON			
Bit-Packed Button / LED and Output Status: Input 1: ENABLED Output 1 Overwrite Input Status: ENABLED (default setting)		OFF	OFF	OFF
Conventional Button / LED and Output Status: Inputs 2-6 (OFF = 0, Steady = 1, Flashing = 2): ENABLED Outputs 2-6 (Overwrite Input Status): ENABLED		ON	OFF	OFF
Bit-Packed Button / LED and Output Status: Input 1: ENABLED Output 1 Overwrite Input Status: DISABLED		OFF	ON	OFF

Continued on page 3

⁽¹⁾ Default device settings are shown. LED and output functionality can change depending on the configuration created with Pro Editor.

⁽²⁾ DIP Switch 1 is only used on 900 MHz models.

Continued from page 2

Device Settings	DIP Switches			
	1	2	3	4
Conventional Button / LED and Output Status: Inputs 2-6 (OFF = 0, Steady = 1, Flashing = 2): ENABLED Outputs 2-6 (Overwrite Input Status): DISABLED		ON	ON	OFF

Bind the LCA130T to a DXM and Assign the Device Address

Before beginning the binding procedure, apply power to all the devices. Separate the radios by two meters when running the binding procedure. Put only one DXM into binding mode at a time to prevent the LCA130T from binding to the wrong DXM.

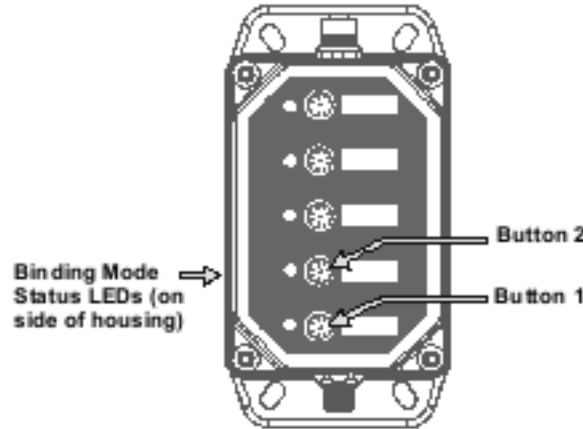

1. On the DXM: Use the arrow keys to select the ISM Radio menu on the LCD and click ENTER.
2. Highlight the Binding menu and click ENTER.
3. Use the arrow keys to select the Node address to bind the LCA130T to.
4. On the LCA130T, enter binding mode:
 - a. Touch and hold button 1.
 - b. Triple-touch button 2.
 - c. Release button 1.

The red and green Binding Mode Status LEDs flash alternately and the sensor searches for a DXM in binding mode. After the LCA130T binds, the LEDs stay solid momentarily, then they flash together four times. The LCA130T exits binding mode.

5. Label the LCA130T with the Node address number for future reference.
6. On the DXM: Click BACK to exit binding for that specific Node address.
7. Repeat steps 3 through 6 and change the Node address for as many LCA130Ts as are needed for your network.
8. On the DXM: After you have finished forming your network, click BACK until you reach the main menu.

LED Behavior for the Nodes

Nodes do not sample inputs until they are communicating with the Gateway. The radios and antennas must be a minimum distance apart to function properly. Recommended minimum distances are:

- 900 MHz (500 mW): 4.57 m (15 ft)
- 2.4 GHz (65 mW): 0.3 m (1 ft)

Binding Mode Status LEDs	Node Status
Flashing green	Radio link okay
Green and red flashing alternately	In Binding mode
Both colors are solid for 4 seconds, then flash 4 times; looks amber	Binding mode is complete
Flashing red, once every 3 seconds	Radio link error
Flashing red, once every second	Device error

LCA130T Modbus Registers

Holding registers

Modbus Registers		EIP Registers		I/O Type	I/O Range		Holding Register Representation (DEC)	
Gateway	Node	Node			Min	Max	Min	Max
1	1 + (Node# x 16)	0 + (Node# x 8)	Instance 100 / N7	Bit Packed Input	0	682	0	682
2	2 + (Node# x 16)	1 + (Node# x 8)		Button 1 Input 1	0	2	0	2

Continued on page 4

Continued from page 3

Modbus Registers		EIP Registers		I/O Type	I/O Range		Holding Register Representation (DEC)		
Gateway	Node	Node			Min	Max	Min	Max	
3	3 + (Node# x 16)	2 + (Node# x 8)		Button 2 Input 2	0	2	0	2	
4	4 + (Node# x 16)	3 + (Node# x 8)		Button 3 Input 3	0	2	0	2	
5	5 + (Node# x 16)	4 + (Node# x 8)		Button 4 Input 4	0	2	0	2	
6	6 + (Node# x 16)	5 + (Node# x 8)		Button 5 Input 5	0	2	0	2	
7	7 + (Node# x 16)	6 + (Node# x 8)		Reserved					
8	8 + (Node# x 16)	7 + (Node# x 8)		Device Message					
9	9 + (Node# x 16)	8 + (Node# x 8)		Instance 112 / N14	Bit Packed Output	0	682	0	682
10	10 + (Node# x 16)	9 + (Node# x 8)			Button 1 Output 1	0	2	0	2
11	11 + (Node# x 16)	10 + (Node# x 8)	Button 2 Output 2		0	2	0	2	
12	12 + (Node# x 16)	11 + (Node# x 8)	Button 3 Output 3		0	2	0	2	
13	13 + (Node# x 16)	12 + (Node# x 8)	Button 4 Output 4		0	2	0	2	
14	14 + (Node# x 16)	13 + (Node# x 8)	Button 5 Output 5		0	2	0	2	
15	15 + (Node# x 16)	14 + (Node# x 8)	Control Message		0	2	0	2	
16	16 + (Node# x 16)	15 + (Node# x 8)	Reserved		0	2	0	2	

To ensure that the LCA130T holds the correct state in case of signal interference, read the button input registers on the LCA130T, and then use the gateway to write the matching value to the button output registers on the LCA130T.

Bit-Packed Holding Register Representation

Buttons	Summed Bit-Packed Register Contents of the LCA130T	
	Touch Value	Touch and Hold Value
Button 1	1	2
Button 2	4	8
Button 3	16	32
Button 4	64	128
Button 5	256	512

By default, an LED and an output are on steady when the corresponding button is touched and released immediately. An LED and an output continuously flash on and off when the button is touched and held for one second. Combinations of button touches and holds are summed.

For example, the value held in register 1 is 6 (2 + 4) when button 1 is flashing (2) and button 2 (4) is steady.

Conventional Button holding Register Representation

Value	Description
0	LED and output off
1	Touch: LED and output are on steady
2	Touch and Hold: LED and output are flashing on and off

LCA130T Specifications

Supply Voltage and Current

- 18 V DC to 30 V DC
- 50 mA maximum current at 18 V DC (exclusive of load)

Supply Protection Circuitry

- Protected against transient voltages

Response Time

- Power-Up Delay: 500 milliseconds maximum
- Input Response: 40 milliseconds maximum
- Output Response: 300 milliseconds maximum

Output Rating

- 4A maximum load (combined or on a single output)

Connections

- Integral 5-pin and 8-pin M12 male quick-disconnect connectors
- Models with a quick disconnect require a mating cordset

Construction

- Polycarbonate

Vibration and Mechanical Shock

- Meets IEC 60068-2-6 requirements (Vibration: 10 Hz to 55 Hz, 0.5 mm amplitude, 5 minutes sweep, 30 minutes dwell)
- Meets IEC 60068-2-27 requirements (Shock: 15G 11 ms duration, half sine wave)

Pro Editor Configuration

Connection to Pro Editor software enables control of:

- Animation: Off, Steady, Flash, Two Color Flash
- Color: Green, Red, Yellow, Blue, Cyan, Magenta, Amber, Rose, Lime Green, Orange, Sky Blue, Violet, Spring Green
- Intensity: Off, Low, Medium, High
- Speed: Slow, Standard, Fast
- Pattern: Normal, Strobe, 3-Pulse, SOS, Random

Pro Converter Cable required to interface between PC and indicator, see Accessories

Operating Conditions

-40 °C to +50 °C (-40 °F to +122 °F)

95% at +50 °C maximum relative humidity (non-condensing)

Environmental Rating

IP65

Radio Range

900 MHz (500 mW): Up to 1.6 km (1 mile) (internal antenna)

2.4 GHz (65 mW): Up to 1000 m (3280 ft) with line of sight (internal antenna)

Antenna Minimum Separation Distance

900 MHz (500 mW): 4.57 m (15 ft)

2.4 GHz (65 mW): 0.3 m (1 ft)

Radio Transmit Power

900 MHz Conducted: 27 dBm (500 mW); EIRP with the supplied 4 dB antenna: 31 dBm (1260 mW)

2.4 GHz Conducted: < 18 dBm (65 mW); EIRP with the supplied 2 dB antenna: < 20 dBm (100 mW)

Spread Spectrum Technology

FHSS (Frequency Hopping Spread Spectrum)

FCC Part 15 Class A for Intentional Radiators

This equipment has been tested and found to comply with the limits for a Class A digital device, pursuant to Part 15 of the FCC Rules. These limits are designed to provide reasonable protection against harmful interference when the equipment is operated in a commercial environment. This equipment generates, uses, and can radiate radio frequency energy and, if not installed and used in accordance with the instruction manual, may cause harmful interference to radio communications. Operation of this equipment in a residential area is likely to cause harmful interference in which case the user will be required to correct the interference at his own expense.

(Part 15.21) Any changes or modifications not expressly approved by the party responsible for compliance could void the user's authority to operate this equipment.

Industry Canada Statement for Intentional Radiators

This device complies with the licence exempt transmitter(s)/receiver(s) that comply with Innovation, Science and Economic Development Canada's licence exempt RSS(s). Operation is subject to the following two conditions:

1. This device may not cause interference.
2. This device must accept any interference, including interference that may cause undesired operation of the device.

Cet appareil convient des émetteurs/récepteurs exempts de licence conformes à la norme Innovation, Sciences et Développement économique Canada. L'exploitation est autorisée aux deux conditions suivantes:

1. L'appareil ne doit pas produire de brouillage.

Required Overcurrent Protection

WARNING: Electrical connections must be made by qualified personnel in accordance with local and national electrical codes and regulations.

Overcurrent protection is required to be provided by end product application per the supplied table.

Overcurrent protection may be provided with external fusing or via Current Limiting, Class 2 Power Supply.

Supply wiring leads < 24 AWG shall not be spliced.

For additional product support, go to www.bannerengineering.com.

Supply Wiring (AWG)	Required Overcurrent Protection (A)	Supply Wiring (AWG)	Required Overcurrent Protection (A)
20	5.0	26	1.0
22	3.0	28	0.8
24	1.0	30	0.5

Certifications

Banner Engineering BV
Park Lane, Culliganlaan 2F bus 3
1831 Diegem, BELGIUM



Turck Banner LTD Blenheim House
Blenheim Court
Wickford, Essex SS11 8YT
GREAT BRITAIN



(CE/UKCA approval only applies to 2.4 GHz models)

900 MHz Compliance (RM7023 Radio Module)

Radio module is indicated by the product label marking

Contains FCC ID: UE3RM7023: FCC Part 15, Subpart C, 15.247

Contains IC: 7044A-RM7023

2.4 GHz Compliance (SX243 Radio Module)

Radio module is indicated by the product label marking

Contains FCC ID: UE3SX243: FCC Part 15, Subpart C, 15.247

Radio Equipment Directive (RED) 2014/53/EU

ETSI/EN: EN 300 328 V2.2.2 (2019-07) [RED HarmStds]

Contains IC: 7044A-SX243

2. L'utilisateur de l'appareil doit accepter tout brouillage radioélectrique subi, même si le brouillage est susceptible d'en compromettre le fonctionnement.

Dimensions

All measurements are listed in millimeters [inches], unless noted otherwise.

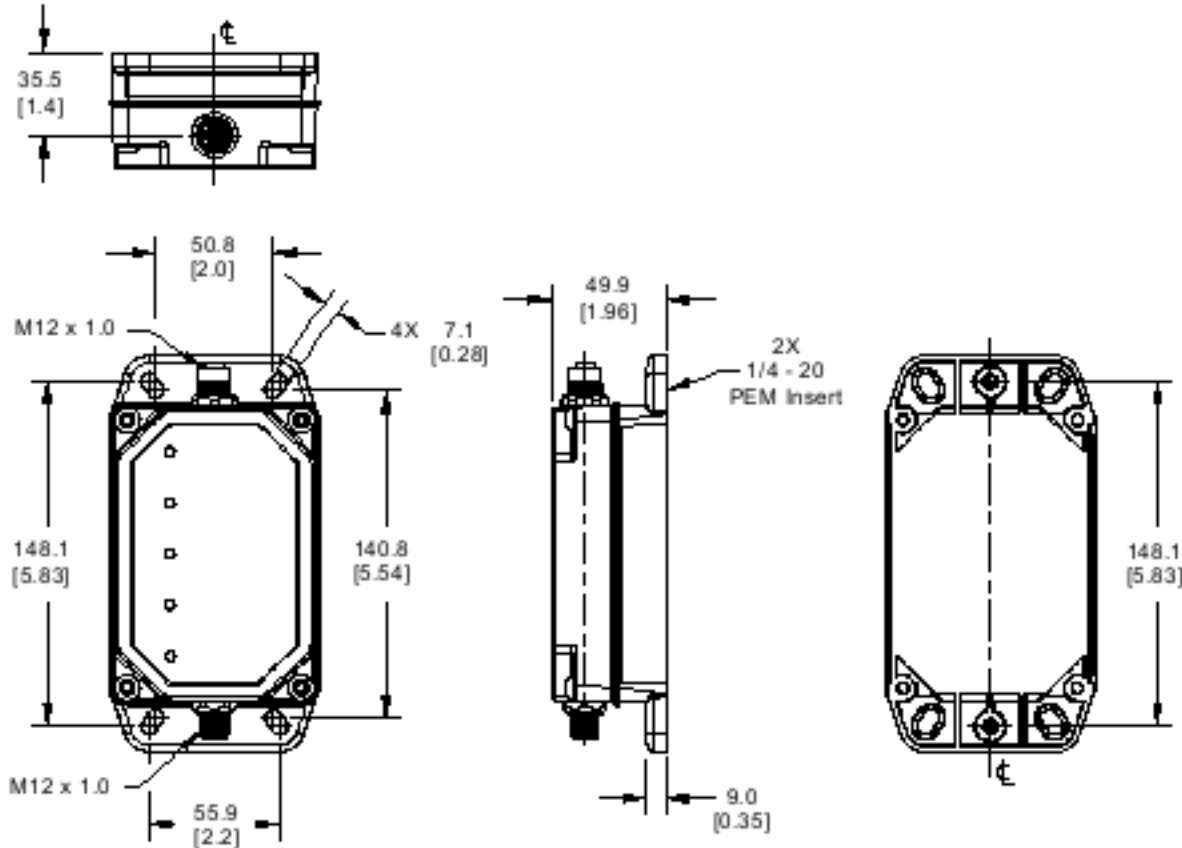

Accessories

Cordsets

5 Pin Threaded M12 Cordsets—Single Ended				
Model	Length	Style	Dimensions	Pinout (Female)
MQDC1-501.5	0.5 m (1.5 ft)	Straight		<p>1 = Brown 2 = White 3 = Blue 4 = Black 5 = Gray</p>
MQDC1-503	0.9 m (2.9 ft)			
MQDC1-506	2 m (6.5 ft)			
MQDC1-515	5 m (16.4 ft)			
MQDC1-530	9 m (29.5 ft)			
MQDC1-560	18 m (59 ft)			
MQDC1-5100	31 m (101.7 ft)			

5 Pin Threaded M12 Cordsets—Double Ended					
Model	Length	Style	Dimensions	Pinout (Male)	Pinout (Female)
MQDEC-501SS	0.31 m (1.02 ft)	Male Straight/ Female Straight		<p>1 = Brown 2 = White 3 = Blue</p>	<p>4 = Black 5 = Gray</p>
MQDEC-503SS	0.91 m (2.99 ft)				
MQDEC-506SS	1.83 m (6 ft)				
MQDEC-512SS	3.66 m (12 ft)				
MQDEC-515SS	5 m (16.4 ft)				
MQDEC-530SS	9 m (29.5 ft)				
MQDEC-550SS	15 m (49.2 ft)				

9 Pin Threaded M12 Connectors—Quick Ended				
Model	Length	Style	Dimensions	Pinout
MQDEC1-803SS	1 m (3.28 ft)	Male Straight / Female Straight		1 = White 2 = Brown 3 = Green 4 = Yellow 5 = Gray 6 = Pink 7 = Blue 8 = Red
MQDEC1-806SS	2 m (6.56 ft)			
MQDEC1-810SS	3 m (9.84 ft)			
MQDEC1-815SS	5 m (16.4 ft)			
MQDEC1-830SS	9 m (29.5 ft)			
MQDEC1-850SS	15 m (49.2 ft)			
MQDEC1-8100SS	30.5 m (100 ft)			
MQDEC1-8200SS	61 m (200 ft)			

Pro Editor Hardware

<p>MQDC-506-USB</p> <ul style="list-style-type: none"> • Pro Converter Cable • 1.83 m (6 ft) length 5-pin M12 quick disconnect to Device and USB to PC • Required for connection to Pro Editor 	
<p>CSB-M1251FM1251M</p> <ul style="list-style-type: none"> • 5-pin parallel Y splitter (Male-Male-Female) • For full Pro Editor preview capability • Requires external power supply, sold separately 	
<p>PSW-24-1</p> <ul style="list-style-type: none"> • 24 V DC, 1 A power supply • 2 m (6.5 ft) PVC cable with M12 quick disconnect • Provides external power with splitter cable, sold separately 	
<p>PSW-24-2</p> <ul style="list-style-type: none"> • 24 V DC, 2 A power supply • 3.5 m (11.5 ft) PVC cable with M12 quick disconnect • Provides external power with splitter cable, sold separately 	
<p>PSD-24-4</p> <ul style="list-style-type: none"> • 90 to 264 V AC 50/60 Hz input • Includes a 1.8 m (6 ft) US style 5-15P input plug • 24 V DC UL Listed Class 2 M12 connector output • 4 A total current 	
<p>ACC-PRO-CABLE5</p> <ul style="list-style-type: none"> • Mating accessory for cabled and terminal models • 150 mm (6 inch) PVC cable with M12 quick disconnect • Lever wire nuts included (qty 5) • Required to connect cabled models and screw terminal models to Pro Converter Cable, sold separately 	

MQDC-801-5M-PRO

- 8-pin to 5-pin double-ended cordset
- 0.31 m (1 ft) PVC cable with M12 quick disconnects
- Required to connect 8-pin Pro Series-enabled devices to Pro Converter Cable (MQDC-506-USB), sold separately



Banner Engineering Corp Limited Warranty

Banner Engineering Corp. warrants its products to be free from defects in material and workmanship for one year following the date of shipment. Banner Engineering Corp. will repair or replace, free of charge, any product of its manufacture which, at the time it is returned to the factory, is found to have been defective during the warranty period. This warranty does not cover damage or liability for misuse, abuse, or the improper application or installation of the Banner product.

THIS LIMITED WARRANTY IS EXCLUSIVE AND IN LIEU OF ALL OTHER WARRANTIES WHETHER EXPRESS OR IMPLIED (INCLUDING, WITHOUT LIMITATION, ANY WARRANTY OF MERCHANTABILITY OR FITNESS FOR A PARTICULAR PURPOSE), AND WHETHER ARISING UNDER COURSE OF PERFORMANCE, COURSE OF DEALING OR TRADE USAGE.

This Warranty is exclusive and limited to repair or, at the discretion of Banner Engineering Corp., replacement. IN NO EVENT SHALL BANNER ENGINEERING CORP. BE LIABLE TO BUYER OR ANY OTHER PERSON OR ENTITY FOR ANY EXTRA COSTS, EXPENSES, LOSSES, LOSS OF PROFITS, OR ANY INCIDENTAL, CONSEQUENTIAL OR SPECIAL DAMAGES RESULTING FROM ANY PRODUCT DEFECT OR FROM THE USE OR INABILITY TO USE THE PRODUCT, WHETHER ARISING IN CONTRACT OR WARRANTY, STATUTE, TORT, STRICT LIABILITY, NEGLIGENCE, OR OTHERWISE.

Banner Engineering Corp. reserves the right to change, modify or improve the design of the product without assuming any obligations or liabilities relating to any product previously manufactured by Banner Engineering Corp. Any misuse, abuse, or improper application or installation of this product or use of the product for personal protection applications when the product is identified as not intended for such purposes will void the product warranty. Any modifications to this product without prior express approval by Banner Engineering Corp will void the product warranties. All specifications published in this document are subject to change; Banner reserves the right to modify product specifications or update documentation at any time. Specifications and product information in English supersede that which is provided in any other language. For the most recent version of any documentation, refer to: www.bannerengineering.com.

For patent information, see www.bannerengineering.com/patents.