

M-H1 Features

The Sure Cross® wireless system is a radio frequency network with integrated I/O that operates in most environments to eliminate the need for wiring runs. Wireless MultiHop data radio networks are formed around a MultiHop master and one or more slaves and extend the range of a Modbus or other serial communication network.

- Wireless industrial I/O device with four sinking discrete inputs, two NMOS discrete outputs, two analog (0–20 mA) inputs, one thermistor input, one counter input, and two switch power outputs
- Selectable transmit power levels of 250 mW or 1 Watt for 900 MHz models and 65 mW for 2.4 GHz models
- FlexPower® power options allow for 10 V DC to 30 V DC, solar, and battery power sources for low-power applications.
- Self-healing, auto-routing radio frequency network with multiple hops extends the network's range and improves radio link performance
- Serial and I/O communication on a Modbus platform
- Message routing improves link performance
- DIP switches select operational modes: master, repeater, or slave
- Built-in site survey mode enables rapid assessment of a location's RF transmission properties
- Frequency Hopping Spread Spectrum (FHSS) technology ensures reliable data delivery



MultiHop M-H1 Models

Model	Frequency	Power	Housing	I/O
DX80DR9M-H1	900 MHz ISM Band	10 to 30 V DC or battery supply module	IEC IP67; NEMA 6	Inputs: Four sinking discrete, two 0 to 20 mA analog, one thermistor, one sinking counter Outputs: Two NMOS discrete, two switch power Serial interface: RS-485
DX80DR9M-H1E		10 to 30 V DC or integrated battery	IP65, NEMA 4X	
DX80DR2M-H1	2.4 GHz ISM Band	10 to 30 V DC or battery supply module	IEC IP67; NEMA 6	
DX80DR2M-H1E		10 to 30 V DC or integrated battery	IP65, NEMA 4X	



DX80...C (IP20; NEMA 1) models are also available. To order this model with an IP20 housing, add a C to the end of the model number: DX80DR9M-H1C.
To order an integrated battery model without the battery, add a -NB to the model number. If you purchase a model without the battery, Banner Engineering recommends lithium D cell battery BWA-BATT-001.

Configuration Instructions

Set Up Your MultiHop Network

To set up and install your wireless MultiHop network, follow these steps:

1. If your radios have DIP switches, configure the DIP switches of all devices.
2. Connect the sensors to the MultiHop radios if applicable.
3. Apply power to all devices.
4. If your MultiHop radio has rotary dials, set the MultiHop Radio ID. If your MultiHop radio has no rotary dials, continue to the next step.
5. Form the wireless network by binding the server and repeater radios to the client radio. If the binding instructions are not included in this datasheet, refer to the quick start guide or product manual.
6. Observe the LED behavior to verify the devices are communicating with each other.
7. Configure any I/O points to use the sensors connected to the Sure Cross devices.
8. Conduct a site survey between the MultiHop radios. If the site survey instructions are not included in this datasheet, refer to the product manual.
9. Install your wireless sensor network components. If the installation instructions are not included in this datasheet, refer to the product manual.

For additional information, refer to one of the following documents:

- MultiHop Data Radio Quick Start Guide: [152653](#)
- MultiHop Data Radio Instruction Manual: [151317](#)
- MultiHop Register Guide: [155289](#)

Configure the DIP Switches

Before changing DIP switch positions, disconnect the power ⁽¹⁾. Any changes made to the DIP switches are not recognized until after power is cycled to the device. For parameters not set using the DIP switches, use the configuration software to make configuration changes. For parameters set using the DIP switches, the DIP switch positions override any changes made using the configuration software.

Access the Internal DIP Switches

Follow these steps to access the internal DIP switches.

1. Unscrew the four screws that mount the cover to the bottom housing.
2. Remove the cover from the housing without damaging the ribbon cable or the pins the cable plugs into.
3. Gently unplug the ribbon cable from the board mounted into the bottom housing. Skip this step if there is no ribbon cable (integrated battery models) or the ribbon cable is glued down (for C housing models).
4. Remove the black cover plate from the bottom of the device's cover.
The DIP switches are located behind the rotary dials.
5. Make the necessary changes to the DIP switches.
6. Place the black cover plate back into position and gently push into place.
7. If necessary, plug the ribbon cable in after verifying that the blocked hole lines up with the missing pin.
8. Mount the cover back onto the housing.

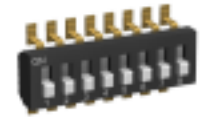

DIP Switch Settings (MultiHop)

Device Settings	Switches							
	1	2	3	4	5	6	7	8
Serial line baud rate 19200 OR User defined receiver slots	OFF ¹	OFF ¹						
Serial line baud rate 38400 OR 32 receiver slots	OFF	ON						
Serial line baud rate 9600 OR 128 receiver slots	ON	OFF						
Serial line baud rate Custom OR 4 receiver slots	ON ²	ON ²						
Parity: None			OFF ¹	OFF ¹				
Parity: Even			OFF	ON				
Parity: Odd			ON	OFF				
Disable serial (low power mode) and enable the receiver slots select for switches 1-2			ON ²	ON ²				
Transmit power 900 MHz radios: 1.00 Watt (30 dBm) 2.4 GHz radios: 0.065 Watts (18 dBm) and 60 ms frame					OFF ¹			
Transmit power 900 MHz radios: 0.25 Watts (24 dBm) 2.4 GHz radios: 0.065 Watts (18 dBm) and 40 ms frame					ON			
Application mode: Modbus						OFF ¹		
Application mode: Transparent						ON		
MultiHop radio setting: Repeater							OFF ¹	OFF ¹
MultiHop radio setting: Master							OFF	ON
MultiHop radio setting: Slave							ON ²	OFF ²
MultiHop radio setting: Reserved							ON	ON

¹ Default configuration

² Default configuration for the E housing models only

Application Mode

The MultiHop radio operates in either Modbus mode or transparent mode. Use the internal DIP switches to select the mode of operation. All MultiHop radios within a wireless network must be in the same mode.

Modbus mode uses the Modbus protocol for routing packets. In Modbus mode, a routing table is stored in each parent device to optimize the radio traffic. This allows for point-to-point communication in a multiple data radio network and acknowledgment/retry of radio packets. To access a radio's I/O, the radios must be running in Modbus mode.

In transparent application mode, all incoming packets are stored, then broadcast to all connected data radios. The data communication is packet-based and not specific to any protocol. The application layer is responsible for data integrity. For one-to-one data radios it is possible

⁽¹⁾ For devices powered by batteries integrated into the housing, triple-click button 2, then double-click button 2 to reset the device without removing the battery.

to enable broadcast acknowledgment of the data packets to provide better throughput. In transparent mode, there is no access to the radio's I/O.

Baud Rate and Parity

The baud rate (bits per second) is the data transmission rate between the device and whatever it is physically wired to. Set the parity to match the parity of the device you are wired to.

Disable Serial

Disable an unused local serial connection to reduce the power consumption of a data radio powered from the solar assembly or from batteries. All radio communications remain operational.

Receiver Slots

The number of receiver slots indicates the number of times out of 128 slots/frames the radio can transmit to its parent radio. Setting a slave's receiver slots to four reduces the total power consumption by establishing that the slave can only transmit to its parent four times per 128 slots.

Transmit Power Levels/Frame Size

The 900 MHz data radios can be operated at 1 Watt (30 dBm), 0.5 W (27 dBm), or 0.25 W (24 dBm). For most models, the default transmit power is 1 W or 0.5 W.

For 2.4 GHz radios, the transmit power is fixed at 0.065 W (18 dBm) and DIP switch 5 is used to set the frame timing. The default position (OFF) sets the frame timing to 60 milliseconds. To increase throughput, set the frame timing to 40 milliseconds. For battery-powered devices, increasing the throughput decreases battery life.

IMPORTANT: Prior to date code 15341 and radio firmware version 3.6, the frame timing was 40 ms (OFF) or 20 ms (ON).

Wire Your Sure Cross Device

Use the following wiring diagrams to first wire the sensors and then apply power to the Sure Cross® devices.

M-H1 Terminal Blocks and Wiring

Connecting power to the communication pins will cause permanent damage. For the DX8x...C models, PWR in the wiring diagram refers to V+ on the wiring board and GND in the wiring diagram refers to V- on the wiring board. Do not exceed analog input ratings for analog inputs. Only connect sensor outputs to analog inputs.

M-H1	M-H1C	M-H1E
<p>Aix or Ax. Analog IN x AX1. Counter IN. AX2. Thermistor IN. Dix. Discrete IN x DOx. Discrete OUT x</p>	<p>B+. 3.6 V DC to 5.5 V DC (use for battery-powered models only) RX/-. Serial communication line for the Gateway. No connection for Nodes TX/+. Serial communication line for the Gateway; no connection for Nodes</p>	<p>GND. Ground/DC common connection PWR. 10 V DC to 30 V DC power connection SPx. Switch Power; provides variable power sources for external devices</p>
<p><i>Discrete Input Wiring for PNP Sensors</i></p>	<p><i>Discrete Input Wiring for NPN Sensors</i></p>	<p><i>Discrete Output Wiring (NPN or NMOS)</i></p>

Continued on page 4

Continued from page 3

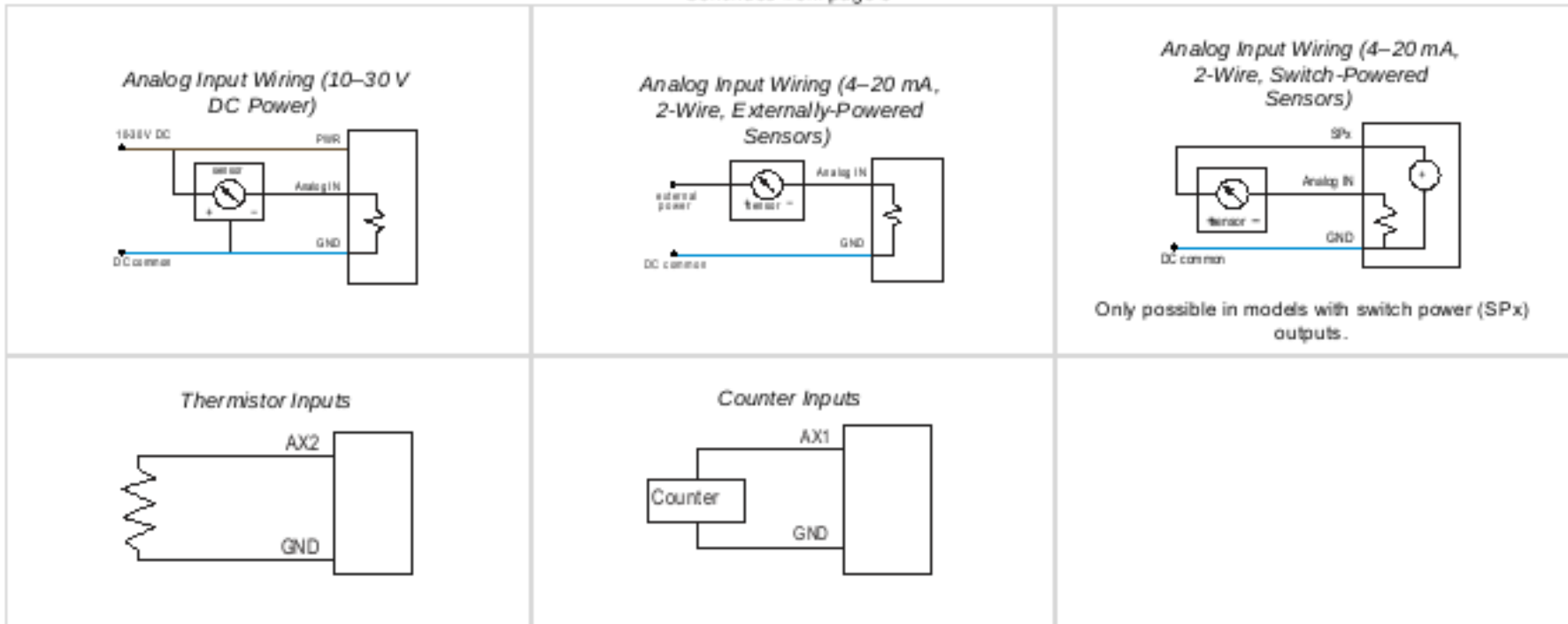

Apply Power to the RS-485 FlexPower MultiHop Model

Connecting power to the communication pins will cause permanent damage. For FlexPower devices, do not apply more than 5.5 V to the gray wire. The FlexPower MultiHop radios operate equally well when powered from the brown or gray wire; it is not necessary to supply both. The power for the sensors can be supplied by the radio's SPx terminals or from the 10 V DC to 30 V DC used to power the radio.

5-pin M12 Male Quick Disconnect Connector	Pin	Wire Color	Wiring Description
	1	Brown (br)	10 V DC to 30 V DC
	2	White (wh)	RS-485 / D1 / B / +
	3	Blue (bu)	DC common (GND)
	4	Black (bk)	RS-485 / D0 / A / -
	5	Gray (gy)	3.6 V DC to 5.5 V DC

Apply Power to the DX80...M-HxC Model

Connecting power to the communication pins will cause permanent damage. For FlexPower devices, do not apply more than 5.5 V to the gray wire. The FlexPower MultiHop radios operate equally well when powered from the brown or gray wire; it is not necessary to supply both. The power for the sensors can be supplied by the radio's SPx terminals or from the 10 V DC to 30 V DC used to power the radio.

Terminal	Wiring Description	Terminal	Wiring Description
V+	10 V DC to 30 V DC	Rx/-	RS-485 / D0 / A / -
Tx+	RS-485 / D1 / B / +	B+	3.6 V DC to 5.5 V DC
V-	DC common (GND)		

Apply Power to the DX80...E Radios

Connecting power to the communication pins will cause permanent damage. The integrated battery DX80...E radios may also be powered by 10 V DC to 30 V DC. The power for the sensors can be supplied by the radio's SPx terminals or from the 10 V DC to 30 V DC used to power the radio. The BAT connection is a low voltage connection to the internal battery. Remove the internal battery if a low voltage source is connected to the BAT terminal. When powering the device from the integrated battery, the BAT connection must remain open.

	Integrated battery (RS-485) for P1E, M-H1E, M-H12E, and P16E Models	Integrated battery (RS-232) for P3E, P4E, M-H3E, and M-H4E Models
	1	10 V DC to 30 V DC (optional)
	2	RS-485 / D1 / B / +
	3	DC common (GND)
	4	RS-485 / D0 / A / -
		10 V DC to 30 V DC (optional)
		RS-232 Tx
		DC common (GND)
		RS-232 Rx

Set the MultiHop Radio ID

The Modbus ID is an identifying number used for devices within a Modbus system. When using more than one Modbus peripheral, assign each peripheral device a unique ID number.

For MultiHop radios with rotary dials, use the rotary dials to set the device's MultiHop Radio ID. The left dial sets the left digit and the right dial sets the right digit.

- Modbus IDs 01 through 10—Reserved for servers directly connected to the host (local I/O). Polling messages addressed to these devices are not relayed over the wireless link.
- Modbus IDs 11 through 60—Use for MultiHop client, repeater, and server radios. Up to 50 devices (local servers and remote servers) may be used in this system.

If your MultiHop radio does not have rotary dials, you must use the master radio to set the Modbus ID during the binding process.

MultiHop Configuration Software

Use Banner's MultiHop Configuration Software to view your MultiHop radio network and configure the radio and its I/O.

MultiHop Configuration Software Network and Device Overview screen

Name	Role	Modbus Address	Device Address	Parent Address	Signal Strength	Green	Yellow	Red	Mixers	Serial Number	Model Number	Build Date	RF FW Ver	RF FW Ver	RF FW Ver	RF FW Ver	LCD FW Ver	LCD FW Ver	LCD FW Ver	LCD FW Ver
Master 900MHz H15	Master	1	23046	23046	0	0	0	0	0	154918	106215	051544	151060	3.0C	175070	1.0				
DATA RADIO DEVICE	Slave	35	34520	23046	50	0	50	0	0	100056	000000	000000	105062	3.0E	156481	0.2A				
DATA RADIO DEVICE	Slave	17	24200	23046	0	0	0	0	0	155272	151607	051544	100000	3.4	157721	1.1				
MultiHop Data Radio	Slave	14	64179	23046	0	0	0	0	0	195251	157096	051230	157719	2.2	157722	1.0				
DATA RADIO DEVICE	Slave	45	63129	23046	0	0	0	0	0	200737	151607	051415	100000	2.6	157721	1.1				
DATA RADIO DEVICE	Slave	19	24203	23046	0	0	0	0	0	155275	151607	051544	100000	3.4	157721	1.1				
DATA RADIO DEVICE	Slave	90	4775	23046	0	0	0	0	0	135647	103420	051520	100000	2.6	157721	1.1				
MultiHop Data Radio	Slave	15	64180	23046	0	0	0	0	0	195252	157096	051230	157719	2.2	157722	1.0				
DATA RADIO DEVICE	Slave	37	50005	23046	0	0	0	0	0	842437	190055	1541	100345	3.1	100449	0.1C				
MultiHop Data Radio	Slave	16	64184	23046	0	0	0	0	0	195256	157096	051230	157719	2.2	157722	1.0				
DATA RADIO DEVICE	Slave	20	24190	23046	0	0	0	0	0	155268	151607	051544	100000	3.4	157721	1.1				
DATA RADIO DEVICE	Slave	36	50006	23046	0	0	0	0	0	842438	190055	1541	100345	3.1	100449	0.1C				
MH MGate SID 13	Slave	13	64176	23046	0	0	0	0	0	195248	157096	051230	157719	2.2	157722	1.0				
DATA RADIO DEVICE	Slave	18	24202	23046	0	0	0	0	0	155274	151607	051544	100000	3.4	157721	1.1				
DATA RADIO DEVICE	Slave	27	9019	23046	0	0	0	0	0	271963	151607	051425	100000	2.6	157721	1.1				
MultiHop Radio H12	Repeater	91	50291	23046	78	70	0	0	22	123617	151605	1512	140091	2.2	151006	1.3	136499	3.2	140000	1.0
DATA RADIO DEVICE	Slave	84	4794	50291	0	0	0	0	0	135666	103420	051520	100000	2.6	157721	1.1				
DATA RADIO DEVICE	Slave	32	9021	50291	0	0	0	0	0	271965	151607	051425	100000	2.6	157721	1.1				
MH MGate SID 12	Slave	12	64185	50291	0	0	0	0	0	195257	157096	051230	157719	2.2	157722	1.0				
MultiHop Data Radio	Slave	75	29005	50291	0	0	0	0	0				100000	2.6	157722	1.1				
DATA RADIO DEVICE	Slave	31	65190	50291	0	0	0	0	0	261006	151607	051417	100000	2.6	157721	1.1				
DATA RADIO DEVICE	Slave	82	4744	50291	0	0	0	0	0	135616	103420	051520	100000	2.6	157721	1.1				
MH MGate SID 11	Slave	11	64181	50291	0	0	0	0	0	195253	157096	051230	157719	2.2	157722	1.0				
DATA RADIO DEVICE	Slave	83	4743	50291	0	0	0	0	0	135615	103420	051520	100000	2.6	157721	1.1				

The software connects to a MultiHop client radio using one of four methods.

- Serial; using a USB to RS-485 (for RS-485 radios) or a USB to RS-232 (for RS-232 radios) converter cable.
- Modbus TCP; using an Ethernet connection to an Ethernet radio client.
- Serial DXM; using a USB cable to a DXM Controller to access a MultiHop client radio.
- TCP DXM; using an Ethernet connection to a DXM Controller to access a MultiHop client radio.

Banner recommends using BWA-UCT-900, an RS-485 to USB adapter cable with a wall plug that can power your radio while you configure it. The adapter cable is not required when connecting to a DXM Controller.

Download the most recent software revision from the Wireless Reference Library on Banner Engineering's website: www.bannerengineering.com.

Installing Your Sure Cross® Radios

Please refer to one of these instruction manuals to install your wireless network components.

- DX80 Performance Wireless I/O Network Instruction Manual: [132607](#)
- MultiHop Data Radio Instruction Manual: [151317](#)

Modbus Registers

Register (4xxxx)	Input #	Input Type	Units	I/O Range		Holding Register Representation		Terminal Block Labels
				Min. Value	Max. Value	Min. (Dec.)	Max. (Dec.)	
1	1	Discrete IN 1	-	0	1	0	1	DI1
2	2	Discrete IN 2	-	0	1	0	1	DI2
3	3	Discrete IN 3	-	0	1	0	1	DI3
4	4	Discrete IN 4	-	0	1	0	1	DI4
5	5	Analog IN 1	mA	0.0	20.0	0	65535	AI1
6	6							
7	7	Analog IN 3	mA	0.0	20.0	0	65535	AI3

Continued on page 6

Continued from page 5

Register (4xxx)	Input #	Input Type	Units	I/O Range		Holding Register Representation		Terminal Block Labels
				Min. Value	Max. Value	Min. (Dec.)	Max. (Dec.)	
8	8	Thermistor	°F	-1638.3	+1638.4	-32768	32767	AX2
9	9	Counter IN 1	MSW ⁽¹⁾	0	65535	0	65535	AX1
10			LSW ⁽²⁾	0	65535	0	65535	

Register (4xxx)	Output #	Output Type	Units	I/O Range		Holding Register Representation		Terminal Block Labels
				Min. Value	Max. Value	Min. (Dec.)	Max. (Dec.)	
501	1	Discrete OUT 1	-	0	1	0	1	DO1
502	2	Discrete OUT 2	-	0	1	0	1	DO2
503	3							
504	4							
505	5	Switch Power 3						SP3
506	6	Switch Power 4						SP4

Modbus Addressing Convention

All Modbus addresses refer to Modbus holding registers. When writing your own Modbus scripts, use the appropriate commands for interfacing to holding registers. Parameter description headings refer to addresses in the range of 40000 as is customary with Modbus convention.

Modbus Register Configuration

Change the factory default settings for the inputs, outputs, and device operations using the device Modbus registers. To change parameters, set the data radio network to Modbus mode and assign the data radio a valid Modbus slave ID.

Generic input or output parameters are grouped together based on the device input or output number: input 1, input 2, output 1 etc. Operation type specific parameters (discrete, counter, analog 4 to 20 mA) are grouped together based on the I/O type number: analog 1, analog 2, counter 1, etc. Not all inputs or outputs may be available for all models. To determine which specific I/O is available on your model, refer to the Modbus Input/Output Register Maps listed in the device's datasheet. For more information about registers, refer to the MultiHop Product Instruction Manual (p/n [151317](#)).

Factory Default Configuration

Default Discrete Inputs (NPN)

Enable	Sample	Boost Enable	Boost Warmup	Boost Voltage	Extended Input Read	NPN/PNP	Sample High	Sample Low
ON	40 ms	OFF	OFF	OFF	OFF	NPN	OFF	OFF

Default Analog Inputs

Enable	Sample	Boost Enable	Boost Warmup	Boost Voltage	Extended Input Read	Analog Max	Analog Min	Enable Fullscale
ON	1 sec	OFF	OFF	OFF	OFF	20000	0	ON

Default Thermistor Inputs

Enable	Sample	Boost Enable	Boost Warmup	Boost Voltage	Extended Input Read	Analog Max	Analog Min	Enable Fullscale	Enable Deg F	Temp Scaling
ON	1 sec	OFF	OFF	OFF	OFF	32767	-32768	OFF	Deg F	× 20

⁽¹⁾ Most Significant Word

⁽²⁾ Least Significant Word

Default Event Counter Inputs

Enable	Sample	Boost Enable	Boost Warmup	Boost Voltage	Extended Input Read	Freq or Event Counter
ON	1 sec	OFF	OFF	OFF	OFF	Event

Default Discrete Outputs

Enable	Flash Enable
ON	OFF

Default Switch Power

I/O Group	Continuous Voltage	Default Output Voltage	Hold Last Voltage Enable
Switch Power (all)	0	0	OFF

Storage and Sleep Modes

Storage Mode (applies to battery-powered models only)—While in storage mode, the radio does not operate. To put any integrated battery Sure Cross® radio into storage mode, press and hold button 1 for five seconds. To wake the device, press and hold button 1 for five seconds. The radio is in storage mode when the LEDs stop blinking, but in some models, the LCD remains on for an additional minute after the radio enters storage mode. After a device has entered storage mode, you must wait one minute before waking it.

Sleep Mode (applies to both battery and 10–30 V DC powered models)—During normal operation, the Sure Cross radio devices enter sleep mode after 15 minutes of operation. The radio continues to function, but the LCD goes blank. To wake the device, press any button.

Install or Replace the Battery on a DX80E Model

Follow these steps to replace the lithium "D" cell battery or batteries in any DX80E model.

1. Remove the four screws mounting the face plate to the housing and remove the face plate. If there is a radio cover on the faceplate, do not remove the radio cover from the faceplate.
2. If applicable, remove the discharged battery or batteries.
3. Install the new battery or batteries.
4. Verify the positive and negative terminals align to the positive and negative terminals of the battery holder mounted within the case.
5. Allow up to 60 seconds for the device to power up.
6. Properly dispose of used batteries according to local regulations by taking it to a hazardous waste collection site, an e-waste disposal center, or other facility qualified to accept lithium batteries.



CAUTION: There is a risk of explosion if the battery is replaced incorrectly.

For outside or high humidity environments, dielectric grease may be applied to the battery terminals to prevent moisture and corrosion buildup.

As with all batteries, these are a fire, explosion, and severe burn hazard. Do not burn or expose them to high temperatures. Do not recharge, crush, disassemble, or expose the contents to water.

For non-hazardous locations, the replacement battery is model BWA-BATT-011. For non-hazardous or hazardous locations, the replacement battery is Xeno model XL-205F, Banner model BWA-BATT-001. For pricing and availability, contact Banner Engineering.



Specifications

Radio Specifications for MultiHop

Supplied Antenna

A 2 dB antenna ships with this device. High-gain antennas are available, but the transmit power and range depends on the antenna gain, environment, and line of sight. Always verify your wireless network's range by performing a Site Survey.

Radio Transmit Power (900 MHz, 1 Watt radios)

Conducted: 30 dBm (1 W)

EIRP with the supplied 2 dB antenna: < 36 dBm

Radio Transmit Power (2.4 GHz radios)

Conducted: < 18 dBm (65 mW)

EIRP with the supplied 2 dB antenna: < 20 dBm (100 mW)

MultiHop H1 Data Radio

Radio Range

- 900 MHz (in 1 Watt mode): Up to 9.6 km (6 miles) with the supplied 2 dB antenna
- 2.4 GHz: Up to 3.2 km (2 miles) with the supplied 2 dB antenna

Antenna Minimum Separation Distance

- 900 MHz (150 mW and 250 mW): 2 m (6 ft) with the supplied 2 dB antenna
- 900 MHz (1 Watt): 4.57 m (15 ft) with the supplied 2 dB antenna
- 900 MHz (500 mW): 4.57 m (15 ft) with the supplied 2 dB antenna
- 2.4 GHz (65 mW): 0.3 m (1 ft) with the supplied 2 dB antenna

Antenna Connection

- Ext. Reverse Polarity SMA, 50 Ohms
- Max Tightening Torque: 0.45 N·m (4 lbf-in)

Spread Spectrum Technology

- FHSS (Frequency Hopping Spread Spectrum)

Radio Packet Size (MultiHop)

- 900 MHz: 175 bytes (85 Modbus registers)
- 2.4 GHz: 75 bytes (37 Modbus registers)

900 MHz Compliance (SX7023EXT Radio Module)

- Radio module is indicated by the product label marking
- Contains FCC ID: UE3SX7023EXT: FCC Part 15, Subpart C, 15.247
- Contains IC: 7044A-SX7023EXT

900 MHz Compliance (RM1809 Radio Module)

- Radio module is indicated by the product label marking
- Contains FCC ID: UE3RM1809: FCC Part 15, Subpart C, 15.247
- Contains IC: 7044A-RM1809
- IFT: RCPBARM13-2283



2.4 GHz Compliance (DX80-2400 Radio Module)

- Radio module is indicated by the product label marking
- Contains FCC ID: UE300DX80-2400: FCC Part 15, Subpart C, 15.247
- Radio Equipment Directive (RED) 2014/53/EU
- Contains IC: 7044A-DX8024
- ANATEL: 15966-21-04042



2.4 GHz Compliance (SX243 Radio Module)

- Radio module is indicated by the product label marking
- Contains FCC ID: UE3SX243: FCC Part 15, Subpart C, 15.247
- Radio Equipment Directive (RED) 2014/53/EU
- ETSI/EN: EN 300 328 V2.2.2 (2019-07) [RED HarmStds]
- Contains IC: 7044A-SX243
- ANATEL: 03737-22-04042



RS-485 Communication Specifications

Communication Hardware (MultiHop RS-485)

- Interface: 2-wire half-duplex RS-485

- Baud rates: 9.6k, 19.2k (default), or 38.4k via DIP switches; 1200 and 2400 via the MultiHop Configuration Software
- Data format: 8 data bits, no parity, 1 stop bit

M-H1 Specifications

Supply Voltage

- FlexPower models: 10 V DC to 30 V DC (Outside the USA: 12 V DC to 24 V DC, $\pm 10\%$) on the brown wire, or 3.6 V DC to 5.5 V DC low power option on the gray wire ⁽¹⁾
- Integrated battery models: 3.6 V DC (internal battery) or 10 V DC to 30 V DC

Power Consumption

- Master radio consumption (900 MHz): Maximum current draw is < 100 mA and typical current draw is < 30 mA at 24 V DC. (2.4 GHz consumption is less.)
- Repeater/slave radio consumption (900 MHz): Maximum current draw is < 40 mA and typical current draw is < 20 mA at 24 V DC. (2.4 GHz consumption is less.)

Housing

- Polycarbonate housing and rotary dial cover; polyester labels; EDPM rubber cover gasket; nitrile rubber, non-sulphur cured button covers
- Weight: 0.26 kg (0.57 lbs)
- M-Hx and M-HxC models: Mounting: #10 or M5 (SS M5 hardware included)
- M-HxE models: Mounting: 1/4-inch or M7 (SS M7 hardware included)
- Max. Tightening Torque: 0.56 N·m (5 lbf-in)

⁽¹⁾ For European applications, power this device from a Limited Power Source as defined in EN 60950-1.

Interface

- Two bi-color LED indicators, Two buttons, Six character LCD

Wiring Access

- M-Hx models: Four PG-7, one 1/2-inch NPT, one 5-pin M12 male quick-disconnect connector
- M-HxC models: External terminals
- M-HxE models: Two 1/2-inch NPT ports

Discrete Inputs

- Rating: 3 mA max current at 30 V DC
- Sample Rate: 40 milliseconds
- ON Condition (NPN): Less than 0.7 V
- OFF Condition (NPN): Greater than 2 V or open

Counter Inputs

- Event counter: Input rating 1 Hz to 10 kHz (For battery-powered devices, the recommended input rating is less than 1 kHz)
- Rate (frequency) counter: 1 Hz to 25 kHz
- Threshold: 1.7 V

Analog Inputs

Rating: 24 mA
 Impedance: Approximately 22 Ohms⁽¹⁾
 Sample Rate: 1 second
 Accuracy: 0.1% of full scale +0.01% per °C
 Resolution: 12-bit

Thermistor Input (MultiHop)

Model: Omega's 44006 or 44031 family of 10 kOhm thermistors
 Sample Rate: 1 second
 Accuracy: 0.4 °C (10 °C to 50 °C); Up to 0.8 °C (* 40 °C to 85 °C)

Discrete Output Rating (MultiHop NMOS)

Less than 1 A max current at 30 V DC
 ON-State Saturation: Less than 0.7 V at 20 mA

Discrete Output ON Condition

Less than 0.7 V

Discrete Output OFF Condition

Open

Certifications

(CE/UKCA approval only applies to 2.4 GHz models)



Banner Engineering BV
 Park Lane, Culliganlaan 2F bus 3
 1831 Diegem, BELGIUM



Turck Banner LTD Blenheim House
 Blenheim Court
 Wickford, Essex SS11 8YT
 GREAT BRITAIN



⁽¹⁾ To verify the analog input's impedance, use an Ohm meter to measure the resistance between the analog input terminal (Aix) and the ground (GND) terminal.

Required Overcurrent Protection

WARNING: Electrical connections must be made by qualified personnel in accordance with local and national electrical codes and regulations.

Overcurrent protection is required to be provided by end product application per the supplied table.

Overcurrent protection may be provided with external fusing or via Current Limiting, Class 2 Power Supply.

Supply wiring leads < 24 AWG shall not be spliced.

For additional product support, go to www.bannerengineering.com.

Supply Wiring (AWG)	Required Overcurrent Protection (A)	Supply Wiring (AWG)	Required Overcurrent Protection (A)
20	5.0	28	1.0
22	3.0	28	0.8
24	1.0	30	0.5

Environmental Specifications (IP67 Housing Models)**Operating Conditions**

-40 °C to +85 °C (-40 °F to +185 °F) (Electronics); -20 °C to +80 °C (-4 °F to +176 °F) (LCD)
 95% maximum relative humidity (non-condensing)
 Radiated Immunity: 10 V/m (EN 61000-4-3)

Shock and Vibration

All models meet IEC 60068-2-6 and IEC 60068-2-27 testing criteria

Shock: 30G 11 ms duration, half sine wave per IEC 60068-2-27

Vibration: 10 Hz to 55 Hz, 0.5 mm peak-to-peak amplitude per IEC 60068-2-6

Environmental Ratings

IEC IP67; NEMA 6

For installation and waterproofing instructions, go to www.bannerengineering.com and search for the complete instruction manual (p/n 151317)

Operating the devices at the maximum operating conditions for extended periods can shorten the life of the device.

Environmental Specifications for the C Housings**Operating Conditions**

-40 °C to +85 °C (-40 °F to +185 °F) (Electronics); -20 °C to +80 °C (-4 °F to +176 °F) (LCD)
 95% maximum relative humidity (non-condensing)
 Radiated Immunity: 10 V/m (EN 61000-4-3)

Shock and Vibration

All models meet IEC 60068-2-6 and IEC 60068-2-27 testing criteria

Shock: 30G 11 ms duration, half sine wave per IEC 60068-2-27

Vibration: 10 Hz to 55 Hz, 0.5 mm peak-to-peak amplitude per IEC 60068-2-6

Environmental Ratings

"C" Housing Models/External wiring terminals: IEC IP20;
NEMA 1

Refer to the Sure Cross® DX80 Performance (p/n 132607) or the Sure Cross® MultiHop (p/n 151317) instruction manual for installation and waterproofing instructions.

Operating the devices at the maximum operating conditions for extended periods can shorten the life of the device.

Environmental Specifications for the E Housing

Operating Conditions

-40 °C to +85 °C (-40 °F to +185 °F) (Electronics); -20 °C to +80 °C (-4 °F to +176 °F) (LCD)
95% maximum relative humidity (non-condensing)
Radiated Immunity: 10 V/m (EN 61000-4-3)

Shock and Vibration

All models meet IEC 60068-2-6 and IEC 60068-2-27 testing criteria
Shock: 30G 11 ms duration, half sine wave per IEC 60068-2-27
Vibration: 10 Hz to 55 Hz, 0.5 mm peak-to-peak amplitude per IEC 60068-2-6

Environmental Ratings

IP65
Refer to the Sure Cross® DX80 Performance (p/n 132607) or the Sure Cross® MultiHop (p/n 151317) instruction manual for installation and waterproofing instructions.

Operating the devices at the maximum operating conditions for extended periods can shorten the life of the device.

FCC Part 15 Class A for Intentional Radiators

This equipment has been tested and found to comply with the limits for a Class A digital device, pursuant to Part 15 of the FCC Rules. These limits are designed to provide reasonable protection against harmful interference when the equipment is operated in a commercial environment. This equipment generates, uses, and can radiate radio frequency energy and, if not installed and used in accordance with the instruction manual, may cause harmful interference to radio communications. Operation of this equipment in a residential area is likely to cause harmful interference in which case the user will be required to correct the interference at his own expense.

(Part 15.21) Any changes or modifications not expressly approved by the party responsible for compliance could void the user's authority to operate this equipment.

Industry Canada Statement for Intentional Radiators

This device complies with the essential requirements of the Radio Equipment Directive (2014/53/EU) and the Radio Spectrum Directive (2002/19/EC) of the European Union. Operation is subject to the following two conditions:

1. This device may not cause interference.
2. This device must accept any interference, including interference that may cause undesired operation of the device.

Cet appareil convient des émetteurs/récepteurs exemptés de licence conformes à la norme Innovation, Sciences et Développement économique Canada. L'exploitation est autorisée aux deux conditions suivantes:

1. L'appareil ne doit pas produire de brouillage.
2. L'utilisateur de l'appareil doit accepter tout brouillage radioélectrique subi, même si le brouillage est susceptible d'en compromettre le fonctionnement.

Accessories

Splitter Cordsets

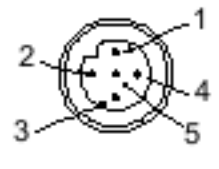
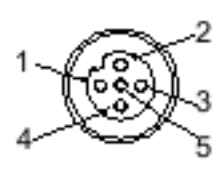
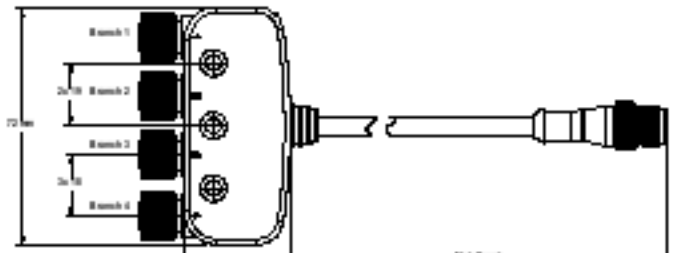
5 Pin Threaded M12 Splitter Cordset with Pig Junction—Ogule Ended				
Model	Trunk (Male)	Branches (Female)	Pigou (Male)	Pigou (Female)
CSB4-M1251M1250	0.3 m (0.98 ft)	Four (no cable)		
			1 = Brown 2 = White 3 = Blue	4 = Black 5 = Gray

5 Pin Threaded M12 Socket Tee				
Model	Description		Pinout (Male)	Pinout (Female)
CSB-M 1250M1250-T	Female trunk, 1 female branch, 1 male branch		 <p>1 = Brown 2 = White 3 = Blue</p>	 <p>4 = Black 5 = Green/Yellow</p>

Thermistor Probes

BWA-THERMISTOR-PROBE-003

- Temperature sensor with thermistor PS103G2
- Beta Value(K) 0-50°C: 3575
- Base thermistor accuracy of 0.2%
- Operating Temperature Range: -20 °C to +105 °C (-4 °F to +221 °F)
- Maximum Power Rating: 30 mW at 25 °C; derated to 1 mW at 125 °C
- Dissipation Constant: 1 mW/°C
- 316 stainless steel finish; PVC insulation

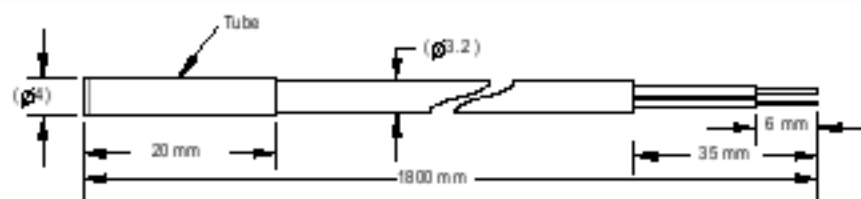

Included with the DX80 and DX80...C Models

- BWA-HW-002: DX80 Access Hardware Kit, containing four PG-7 plastic threaded plugs, four PG-7 nylon gland fittings, four PG-7 hex nuts, one 1/2-inch NPT plug, and one 1/2-inch nylon gland fitting. (Not included with IP20 DX80...C models)
- BWA-HW-001: Mounting Hardware Kit, containing four M5-0.8 × 25mm SS screws, four M5-0.8 × 16 mm SS screws, four M5-0.8 mm SS hex nuts, and four #8-32 × 3/4" SS bolts
- BWA-HW-003: PTFE tape
- BWA-902-C (900 MHz) or BWA-202-C (2.4 GHz): Antenna, 2 dBd Omni, Rubber Swivel RP-SMA Male (not included with internal antenna models)
- MQDC1-506: 5-pin M12 (single ended) straight cordset, 2 m (not included with FlexPower devices)
- BWA-HW-011: IP20 Screw Terminal Headers (2 pack) (included only with the IP20 DX80...C models)
- Product datasheet and product family Quick Start Guide ([128185](#) for Performance models or [152653](#) for MultiHop models)

Included with the DX80..E Models

- Mounting hardware kit
- BWA-HW-003: PTFE tape
- BWA-902-C (900 MHz) or BWA-202-C (2.4 GHz): Antenna, 2 dBd Omni, Rubber Swivel RP-SMA Male. (Not included with Internal antenna models)
- BWA-BATT-001: Replacement battery, 3.6 Volt, "D" Lithium Cell
- BWA-HW-032: Access Hardware for "E" Housing (One each of 1/2-inch plug, 1/2-inch gland)
- Product datasheet and product family Quick Start Guide ([128185](#) for DX80 Gateways or [152653](#) for MultiHop models)

Warnings



WARNING:

- Do not use this device for personnel protection
- Using this device for personnel protection could result in serious injury or death.
- This device does not include the self-checking redundant circuitry necessary to allow its use in personnel safety applications. A device failure or malfunction can cause either an energized (on) or de-energized (off) output condition.

IMPORTANT: Please download the complete MultiHop H1 Data Radio technical documentation, available in multiple languages, from www.bannerengineering.com for details on the proper use, applications, warnings, and installation instructions of this device.

IMPORTANT: Por favor descargue desde www.bannerengineering.com toda la documentación técnica de los MultiHop H1 Data Radio, disponibles en múltiples idiomas, para detalles del uso adecuado, aplicaciones, advertencias, y las instrucciones de instalación de estos dispositivos.

IMPORTANT: Veuillez télécharger la documentation technique complète des MultiHop H1 Data Radio sur notre site www.bannerengineering.com pour les détails sur leur utilisation correcte, les applications, les notes de sécurité et les instructions de montage.

Install and properly ground a qualified surge suppressor when installing a remote antenna system. Remote antenna configurations installed without surge suppressors invalidate the manufacturer's warranty. Keep the ground wire as short as possible and make all ground connections to a single-point ground system to ensure no ground loops are created. No surge suppressor can absorb all lightning strikes; do not touch the Sure Cross® device or any equipment connected to the Sure Cross® device during a thunderstorm.

Exporting Sure Cross® Radios. It is our intent to fully comply with all national and regional regulations regarding radio frequency emissions. Customers who want to re-export this product to a country other than that to which it was sold must ensure the device is approved in the destination country. The Sure Cross wireless products were certified for use in these countries using the antenna that ships with the product. When using other antennas, verify you are not exceeding the transmit power levels allowed by local governing agencies. This device has been designed to operate with the antennas listed on Banner Engineering's website and having a maximum gain of 9 dBi. Antennas not included in this list or having a gain greater than 9 dBi are strictly prohibited for use with this device. The required antenna impedance is 50 ohms. To reduce potential radio interference to other users, the antenna type and its gain should be so chosen such that the equivalent isotropically radiated power (EIRP) is not more than that permitted for successful communication. Consult with Banner Engineering Corp. if the destination country is not on this list.

IMPORTANT:

- Never operate a radio without connecting an antenna
- Operating radios without an antenna connected will damage the radio circuitry.
- To avoid damaging the radio circuitry, never apply power to a Sure Cross® Performance or Sure Cross® MultiHop radio without an antenna connected.

IMPORTANT:

- Electrostatic discharge (ESD) sensitive device
- ESD can damage the device. Damage from inappropriate handling is not covered by warranty.
- Use proper handling procedures to prevent ESD damage. Proper handling procedures include leaving devices in their anti-static packaging until ready for use; wearing anti-static wrist straps; and assembling units on a grounded, static-dissipative surface.

Banner Engineering Corp Limited Warranty

Banner Engineering Corp. warrants its products to be free from defects in material and workmanship for one year following the date of shipment. Banner Engineering Corp. will repair or replace, free of charge, any product of its manufacture which, at the time it is returned to the factory, is found to have been defective during the warranty period. This warranty does not cover damage or liability for misuse, abuse, or the improper application or installation of the Banner product.

THIS LIMITED WARRANTY IS EXCLUSIVE AND IN LIEU OF ALL OTHER WARRANTIES WHETHER EXPRESS OR IMPLIED (INCLUDING, WITHOUT LIMITATION, ANY WARRANTY OF MERCHANTABILITY OR FITNESS FOR A PARTICULAR PURPOSE), AND WHETHER ARISING UNDER COURSE OF PERFORMANCE, COURSE OF DEALING OR TRADE USAGE.

This Warranty is exclusive and limited to repair or, at the discretion of Banner Engineering Corp., replacement. IN NO EVENT SHALL BANNER ENGINEERING CORP. BE LIABLE TO BUYER OR ANY OTHER PERSON OR ENTITY FOR ANY EXTRA COSTS, EXPENSES, LOSSES, LOSS OF PROFITS, OR ANY INCIDENTAL, CONSEQUENTIAL OR SPECIAL DAMAGES RESULTING FROM ANY PRODUCT DEFECT OR FROM THE USE OR INABILITY TO USE THE PRODUCT, WHETHER ARISING IN CONTRACT OR WARRANTY, STATUTE, TORT, STRICT LIABILITY, NEGLIGENCE, OR OTHERWISE.

Banner Engineering Corp. reserves the right to change, modify or improve the design of the product without assuming any obligations or liabilities relating to any product previously manufactured by Banner Engineering Corp. Any misuse, abuse, or improper application or installation of this product or use of the product for personal protection applications when the product is identified as not intended for such purposes will void the product warranty. Any modifications to this product without prior express approval by Banner Engineering Corp will void the product warranties. All specifications published in this document are subject to change; Banner reserves the right to modify product specifications or update documentation at any time. Specifications and product information in English supersede that which is provided in any other language. For the most recent version of any documentation, refer to: www.bannerengineering.com.

For patent information, see www.bannerengineering.com/patents.

Notas Adicionales (con Antena)

Información México: La operación de este equipo está sujeta a las siguientes dos condiciones: 1) es posible que este equipo o dispositivo no cause interferencia perjudicial y 2) este equipo debe aceptar cualquier interferencia, incluyendo la que pueda causar su operación no deseada.

Banner es una marca registrada de Banner Engineering Corp. y podrán ser utilizadas de manera indiscreta para referirse al fabricante. "Este equipo ha sido diseñado para operar con las antenas tipo Omnidireccional para una ganancia máxima de antena de 6 dBd y Yagi para una ganancia máxima de antena 10 dBd que en seguida se enlistan. También se incluyen aquellas con aprobación ATEX tipo Omnidireccional siempre que no excedan una ganancia máxima de antena de 6dBd. El uso con este equipo de antenas no incluidas en esta lista o que tengan una ganancia mayor que 6 dBd en tipo omnidireccional y 10 dBd en tipo Yagi, quedan prohibidas. La impedancia requerida de la antena es de 50 ohms."

Approved Antennas

- BWA-902-C--Antena, Omni 902-928 MHz, 2 dBd, junta de caucho, RP-SMA Macho
- BWA-905-C--Antena, Omni 902-928 MHz, 5 dBd, junta de caucho, RP-SMA Macho
- BWA-906-A--Antena, Omni 902-928 MHz, 6 dBd, fibra de vidrio, 1800mm, N Hembra
- BWA-9Y 10-A--Antena, Yagi, 900 MHz, 10 dBd, N Hembra

Mexican Importer

Banner Engineering de México, S. de R.L. de C.V. | Oued Alfero Siqueiros 103 Pasa 2 Valle Grande | San Pedro Garza García Nuevo León, C. P. 66269

81 8383.2714

Document title: Sure Cross® MultiHop M-H1 Data Radio Datasheet

Part number: 148947

Revision: 0

Original Instructions

© Banner Engineering Corp. All rights reserved.

