

Quick Start Guide Introduction

The Asset Monitoring Gateway with Cloud ID™ from Banner Engineering provides real-time insights about the operation and performance of the assets in your facility. The gateway features a user-friendly, no-code setup and the ability to automatically recognize an array of compatible sensors using the embedded Cloud ID™ intelligence.

This Quick Start Guide describes the necessary steps to apply power, bind sensors to the radio network of the gateway, and activate the gateway on your Banner Cloud Data Services software account.

For a detailed description of the following steps, please scan this code to consult the complete Asset Monitoring Gateway with Cloud ID™ System Manual (pn 222401) or watch the tutorial videos on the product series page at www.bannerengineering.com/AMGCLOUDID.



Configuration Instructions

Unpack and Supply Power to All Devices

1. Install the antenna.
 - a. Securely fasten the ISM radio antenna (BWA-902-C or BWA-202-C) to the Gateway's SMA connection port R.
 - b. If you intend to use cellular communication, securely fasten the cellular antenna (BWA-CELLA-002) to the Gateway's SMA connection port L. If you are not using cellular communication, leave this port capped with the protective cover.
2. Apply power to the Asset Monitoring Gateway:
 - a. Connect the power supply to the Gateway using the corresponding connection port.
 - b. Insert the wall plug of the power supply into a power outlet using the appropriate plug adapter for your region.
3. Apply power to the compatible sensor Nodes:
 - a. For battery-powered devices, access the Node's battery compartment or holder by unfastening the cover and installing the appropriate battery size and voltage using the proper orientation as indicated in the device's datasheet.
 - b. For AC-powered devices, verify the device has been correctly wired and then connect to an appropriate power source as indicated in the device's datasheet.
 - c. Keep the Node covers unfastened until after completing the binding process.

Bind the Sensor Nodes to the Wireless Network

Banner offers an array of compatible Sensor Nodes that can measure vibration, differential pressure, temperature and humidity, tank level, and other data signals that are critical to monitor within an operation. Please visit the series page for the Asset Monitoring Gateway with Cloud ID™ on our website to view the list of compatible Nodes or consult the complete Asset Monitoring Gateway with Cloud ID™ Kit System Manual (pn 222401).

1. On the Gateway: Enter binding mode:
 - a. Use the arrow keys to select the ISM Radio menu on the LCD and press ENTER.
 - b. Highlight the Binding menu and press ENTER.
2. Use the arrow keys to select the Node ID address you intend to assign to the Sensor Node.

You may only use Node IDs 1-40 with the Asset Monitoring Gateway. You must assign a unique Node ID for each Sensor Node in your network.
3. Press ENTER.

The Gateway's display indicates the device is in binding mode.
4. On the Sensor Node: Enter binding mode:

Binding button locations

One button model

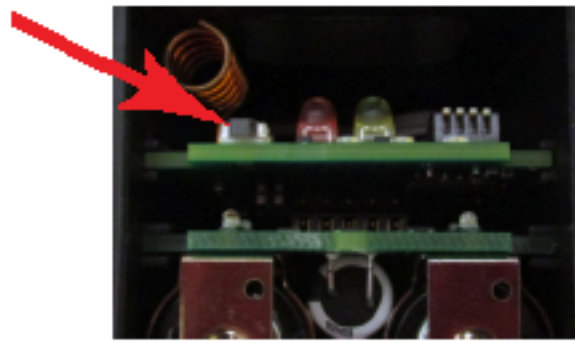

Two button model



- * For one-button Nodes, triple-click the button.
- * For two-button Nodes, triple-click button 2.

The LEDs flash alternately and the Node searches for a Gateway in binding mode. After the Node binds, the LEDs stay solid momentarily, then they flash together four times. The Node automatically exits binding mode and reboots.

5. On the Gateway: Press BACK to exit binding mode for that specific Node address.
The Node LEDs continue to flash red until the Gateway exits binding mode with that Node address. The LED flashes green after the Node and Gateway have synced and are communicating properly. This may take a few moments. Please note: Some Node models also illuminate an amber LED after the device syncs with the Gateway. This indicates the Node is in fast-sampling mode. The Node automatically exits fast-sampling mode after 15 minutes, otherwise you can manually exit fast-sampling mode by clicking the button five times. Fast-sampling mode does not affect the sampling rate of a Cloud ID™ system and may be disregarded.
6. Repeat steps 2-5 for as many Sensor Nodes as are needed for your network.
7. On the Gateway: When you are finished binding, press BACK until you return to the main menu.

Connect to the Local Area Network

By default, the Asset Monitoring Gateways are intended to push data to the Banner Cloud Data Services (BannerCDS) platform using a local area network. A specialized Ethernet cable is included with the Gateway to complete this connection.

1. Connect the Ethernet cable to the corresponding port on the Gateway.
2. Insert the RJ45 connector into a port on the local area network.
3. Configure the Ethernet communication parameters, if necessary.

By default, the Gateway is configured to communicate to a local network using the Dynamic Host Configuration Protocol (DHCP) setting and to act as a client on the network. This setting may work for most applications and no further configuration is needed. Contact your IT professional to ensure the device is not blocked from the local network.

In some applications, your IT professional may prefer to attribute a Static IP Address to the Gateway. This may be done using the LCD menu on the Gateway. To set up a static IP address, follow these steps:

- a. To set a static IP address: On the Gateway, use the arrows to highlight the System Config menu, then press ENTER.
- b. Use the arrow keys to select the Ethernet menu, then press ENTER.
- c. Highlight the DHCP selection, then press ENTER.
- d. Set DHCP to OFF.
- e. When the system requests a restart, press ENTER to confirm.
- f. Navigate back to the Ethernet menu.
- g. Use the arrow keys to select IP, then press ENTER.
The octet of the IP address displays (for example, 192.168.10.1)
- h. Use the arrow keys to scroll numerically to change the IP address as desired. Press ENTER to move to the next octet.
- i. Press ENTER on the final octet to accept the changes.
- j. Cycle power to the Gateway.
The changes are saved on the Gateway and the new IP address is used.
- k. Use the same procedures to set the subnet mask (SN) and default network gateway (GW) to match your network requirements. Your IT department can provide these settings if needed.

The Asset Monitoring Gateway is intended to be deployed primarily using Ethernet communication.

For more information, refer to the Asset Monitoring Gateway with Cloud ID™ System Manual (pn 222401) or watch the tutorial videos on our website at www.bannerengineering.com/AMGCLOUDID.

Configure the Cellular Communication

By default, the Asset Monitoring Gateway with Cloud ID™ is intended to use Ethernet communication. However, it may be preferable to use cellular communication when adding the device to a local area network is difficult, not desired, or when some applications require remote monitoring through a widely available cellular network.

Follow these instructions to configure the Asset Monitoring Gateway for cellular communication, then activate the cellular modem onto the respective network by creating an account at celldata.bannercds.com and purchasing a cellular subscription plan.

1. Connect the power supply to Gateway using the M12 or barrel jack connector and plug the power supply into a wall socket.
2. If applicable, disconnect the Ethernet cable from the Gateway and the local area network.
3. On the Gateway: From the main menu, use the arrow keys to highlight Registers and press ENTER.
4. Scroll to the bottom of the Register list to highlight ForceEthernet. Press ENTER.
5. Use the arrow keys to change the Register value to zero (0). Press ENTER.
By default, this register value is set to one (1).
6. Press ENTER again until SEND is highlighted and blinking.
7. Press ENTER to send the command.
The clock in the upper right corner of the Gateway display pauses briefly while the Gateway reboots. The Gateway has successfully rebooted when the screen returns to the main menu and the clock begins to operate again.

The gateway is now set to communicate through the embedded cellular module. The Asset Monitoring Gateway with Cloud ID™ system transmits data once every ten minutes when communicating via the cellular module, so please allow sufficient time to determine that a successful push has been received by the Banner Cloud Data Services platform.

Activate the Banner Cloud Data Services

Follow these instructions to activate your Banner CDS™ account.

1. Go to the bannercds.com website.
2. Register your account by going to the Sign Up menu.
3. Enter the requested information. The authorization code is on the Authorization Card included with your kit.
4. Read and accept the Services Access and Use Agreement.

Create a New Gateway

Follow these steps to set up a new Gateway.

1. Log into the account and click New Gateway near the top right of the Overview screen.
2. Verify the Gateway Type is set to Cloud ID.
3. Name your Gateway.
4. Select the desired Company from the drop-down list.
5. Enter the serial number into the DXM Serial # field.
The serial number is on the Gateway's label or is listed in the Gateway's menu under System Info > Controller > Serial.
6. Click Save.
The Banner CDS™ software automatically creates dashboard layouts and data sets for each sensor bound to the Asset Monitoring Gateway.

The Banner CDS™ software application creates a site for the system and begins searching for a data push from the Gateway.

These Asset Monitoring Systems are designed to push data once every five minutes with Ethernet communication and once every ten minutes with cellular communication. Therefore, the Gateway could take 5-10 minutes to complete recognition by the Cloud application.

A push success will be indicated on the Gateway display with an S followed by a timestamp on the PUSH line and then refreshing the Banner CDS™ webpage with Connected as the Status.

View Data and Dashboards

After the Banner CDS™ application has detected the Gateway, use the navigation pane on the left side to view the Gateway.

Click Details next to the Gateway Name. The device Details page provides a list of sensor objects for each Sensor Node bound to the system. The model number, connection status, and relevant data registers for each sensor are listed.

To edit the Sensor and Signal Names, click on the Edit button in the specific row.

Sensors details screen

Edit	Write	Reg #	Signal Name	Value	Last Report	Alarm
		12	Status	128	3 days ago	Sensor 01 Status
		13	Temperature °F	74.95 °F	3 days ago	Sensor 01 Temperature °F
		14	Pressure 0-150	0.3007 PSIG	3 days ago	Sensor 01 Pressure 0-150

To view the dashboard for this system, click on Dashboards in the navigation pane and select the Gateway name from the list. Use the system dashboard to visually understand the status of your assets. Each icon represents a node within the system. The icon colors indicate:

- Green for those latest measurements that are within acceptable parameters;
- Yellow for measurements that have surpassed a Warning threshold; and
- Red for measurements that have surpassed a Critical threshold.

Dashboard screen

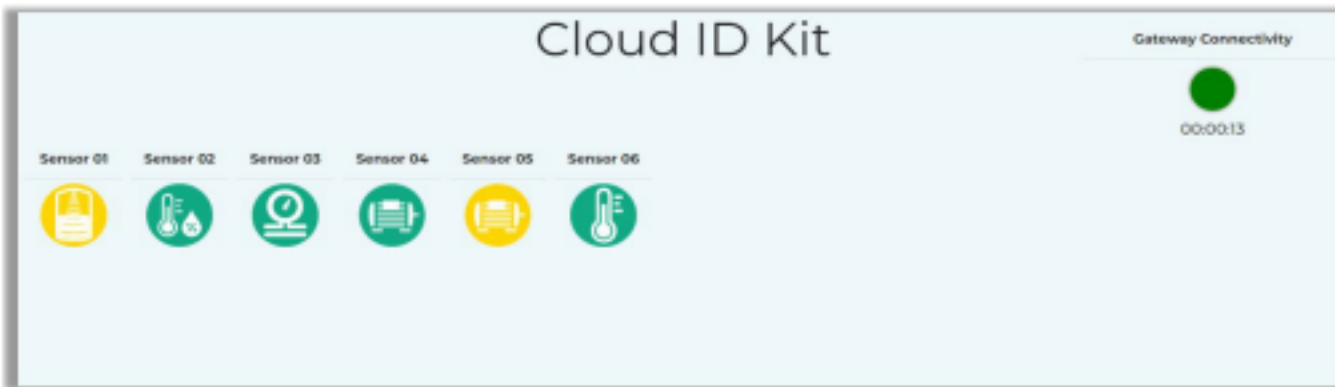

To view and adjust alarm thresholds:

1. Hover over and click the icons to view the default alarms currently established for each Sensor Node.
2. Edit these alarms as needed by clicking on the Edit button next to each alarm signal, or by navigating to the Alerts page and filtering the alert list to the appropriate gateway.
3. On the Alert edit prompt, adjust the comparison operator and threshold values.

Editing sensor thresholds

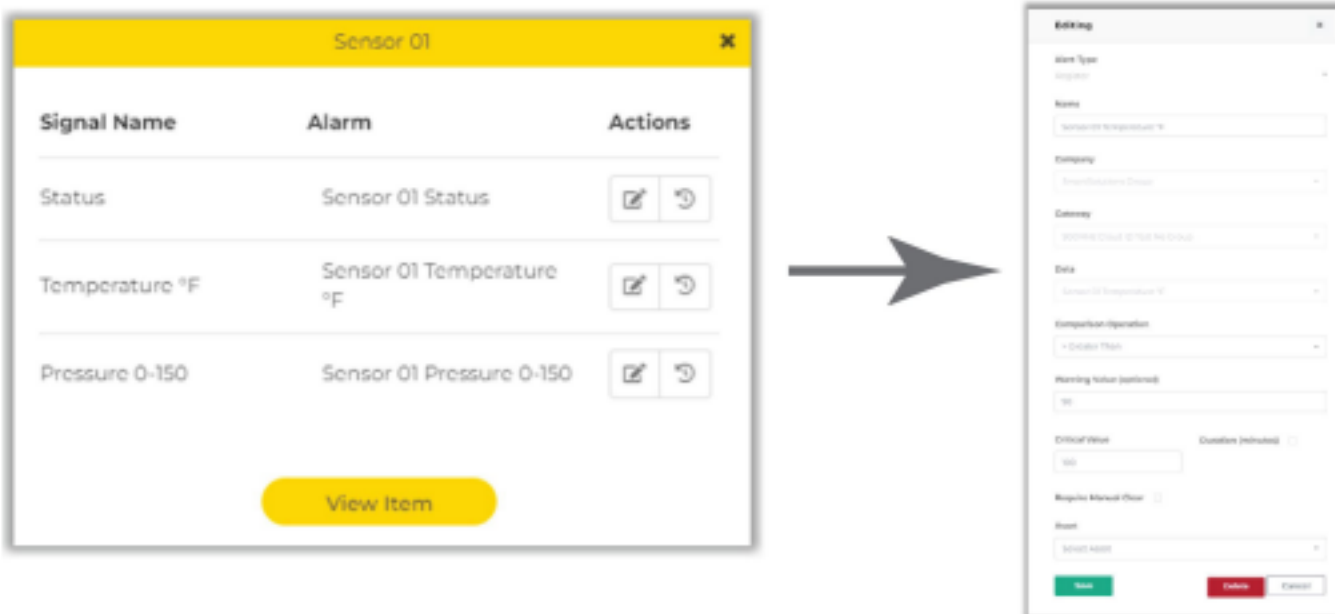

For more information about Alert settings and attributing Notifications to these alarms, please consult the complete Asset Monitoring Gateway with Cloud ID™ System Manual (pn 222401) or watch the tutorial videos on www.bannerengineering.com/AMGCLOUDID.

Asset Monitoring Gateway Specifications

Supply Voltage
12-30 V DC

Use only with a suitable Class 2 power supply (UL) or a Limited Power Source (LPS) (CE) power supply

Construction

Polycarbonate

Environmental Rating

IP67

Operating Conditions

-20 °C to +60 °C (-4 °F to +140 °F)

Push to Cloud Rate

Once every 5 minutes (Ethernet connection) (default)

Once every 10 minutes (cellular connection)

Cellular Connectivity

4G LTE CATM1 (LTE-MNB-IoT)

900 MHz Compliance (SX7023EXT Radio Module)

Radio module is indicated by the product label marking

Contains FCC ID: UE3SX7023EXT: FCC Part 15, Subpart C, 15.247

Contains IC: 7044A-SX7023EXT

900 MHz Compliance (RM1809 Radio Module)

Radio module is indicated by the product label marking

Contains FCC ID: UE3RM1809: FCC Part 15, Subpart C, 15.247

Contains IC: 7044A-RM1809

IFT: RCPBARM13-2283

**2.4 GHz Compliance (SX243 Radio Module)**

Radio module is indicated by the product label marking

Contains FCC ID: UE3SX243: FCC Part 15, Subpart C, 15.247

Radio Equipment Directive (RED) 2014/53/EU

ETSI/EN: EN 300 328 V2.2.2 (2019-07) [RED HarmStds]

Contains IC: 7044A-SX243

ANATEL: 03737-22-04042

**Certifications**Banner Engineering BV
Park Lane, Culliganlaan 2F bus 3
1831 Diegem, BELGIUMBanner Engineering LTD Blenheim House
Blenheim Court
Wickford, Essex SS11 4YT
GREAT BRITAIN

(UL approval applies only to 900 MHz model)

Required Overcurrent Protection

WARNING: Electrical connections must be made by qualified personnel in accordance with local and national electrical codes and regulations.

Overcurrent protection is required to be provided by end product application per the supplied table.

Overcurrent protection may be provided with external fusing or via Current Limiting, Class 2 Power Supply.

Supply wiring leads < 24 AWG shall not be spliced.

For additional product support, go to Key definition for "{keyrefName}" not found in the DITA map.

Supply Wiring (AWG)	Required Overcurrent Protection (A)	Supply Wiring (AWG)	Required Overcurrent Protection (A)
20	5.0	28	1.0
22	3.0	28	0.8
24	1.0	30	0.5

FCC Part 15 Class A for Intentional Radiators

This equipment has been tested and found to comply with the limits for a Class A digital device, pursuant to part 15 of the FCC Rules. These limits are designed to provide reasonable protection against harmful interference when the equipment is operated in a commercial environment. This equipment generates, uses, and can radiate radio frequency energy and, if not installed and used in accordance with the instruction manual, may cause harmful interference to radio communications. Operation of this equipment in a residential area is likely to cause harmful interference in which case the user will be required to correct the interference at his own expense.

Industry Canada Statement for Intentional Radiators

This device contains licence-exempt transmitter(s)/receiver(s) that comply with Innovation, Science and Economic Development Canada's licence-exempt RSS(s). Operation is subject to the following two conditions:

1. This device may not cause interference.
2. This device must accept any interference, including interference that may cause undesired operation of the device.

Cet appareil contient des émetteurs/récepteurs exemptés de licence conformes à la norme Innovation, Sciences, et Développement économique Canada. L'exploitation est autorisée aux deux conditions suivantes:

1. L'appareil ne doit pas produire de brouillage.
2. L'utilisateur de l'appareil doit accepter tout brouillage radioélectrique subi, même si le brouillage est susceptible d'en compromettre le fonctionnement.

Dimensions

All measurements are listed in millimeters, unless noted otherwise.

Key definition for "{keyrefName}" not found in the DITA map. dimensions

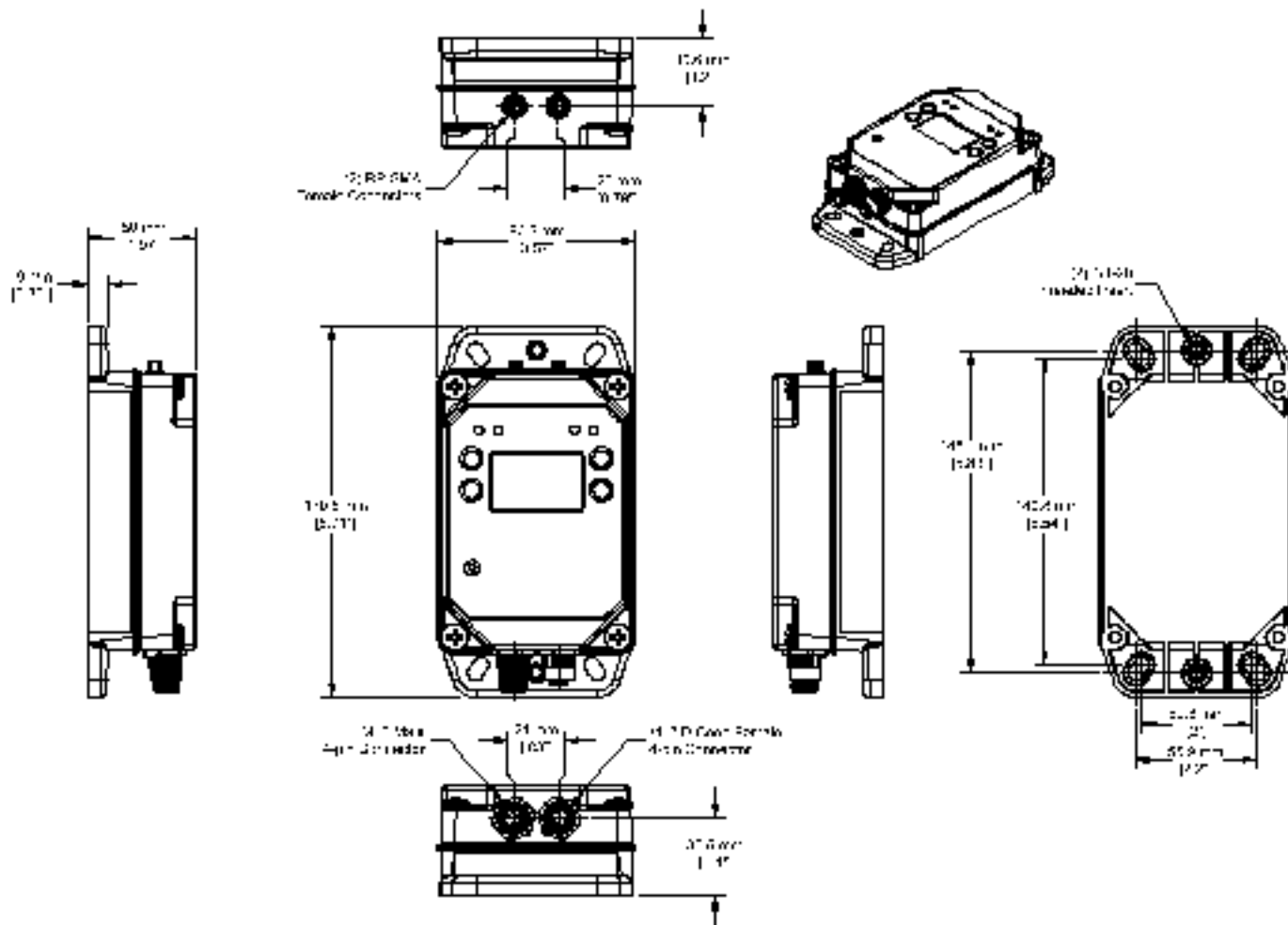

Banner Engineering Corp Limited Warranty

Banner Engineering Corp. warrants its products to be free from defects in material and workmanship for one year following the date of shipment. Banner Engineering Corp. will repair or replace, free of charge, any product of its manufacture which, at the time it is returned to the factory, is found to have been defective during the warranty period. This warranty does not cover damage or liability for misuse, abuse, or the improper application or installation of the Banner product.

THIS LIMITED WARRANTY IS EXCLUSIVE AND IN LIEU OF ALL OTHER WARRANTIES WHETHER EXPRESS OR IMPLIED (INCLUDING, WITHOUT LIMITATION, ANY WARRANTY OF MERCHANTABILITY OR FITNESS FOR A PARTICULAR PURPOSE), AND WHETHER ARISING UNDER COURSE OF PERFORMANCE, COURSE OF DEALING OR TRADE USAGE.

This Warranty is exclusive and limited to repair or, at the discretion of Banner Engineering Corp., replacement. IN NO EVENT SHALL BANNER ENGINEERING CORP. BE LIABLE TO BUYER OR ANY OTHER PERSON OR ENTITY FOR ANY EXTRA COSTS, EXPENSES, LOSSES, LOSS OF PROFITS, OR ANY INCIDENTAL, CONSEQUENTIAL OR SPECIAL DAMAGES RESULTING FROM ANY PRODUCT DEFECT OR FROM THE USE OR INABILITY TO USE THE PRODUCT, WHETHER ARISING IN CONTRACT OR WARRANTY, STATUTE, TORT, STRICT LIABILITY, NEGLIGENCE, OR OTHERWISE.

Banner Engineering Corp. reserves the right to change, modify or improve the design of the product without assuming any obligations or liabilities relating to any product previously manufactured by Banner Engineering Corp. Any misuse, abuse, or improper application or installation of this product or use of the product for personal protection applications when the product is identified as not intended for such purposes will void the product warranty. Any modifications to this product without prior express approval by Banner Engineering Corp will void the product warranties. All specifications published in this document are subject to change; Banner reserves the right to modify product specifications or update documentation at any time. Specifications and product information in English supersede that which is provided in any other language. For the most recent version of any documentation, refer to: www.bannerengineering.com.

For patent information, see www.bannerengineering.com/patents.

Contact Us

Banner Engineering Corp. headquarters is located at: 9714 Tenth Avenue North | Minneapolis, MN 55441, USA | Phone: + 1 888 373 6767

For worldwide locations and local representatives, visit www.bannerengineering.com.

Notas Adicionales (con Antena)

Información México: La operación de este equipo está sujeta a las siguientes dos condiciones: 1) es posible que este equipo o dispositivo no cause interferencia perjudicial y 2) este equipo debe aceptar cualquier interferencia, incluyendo la que pueda causar su operación no deseada.

Banner es una marca registrada de Banner Engineering Corp. y podrán ser utilizadas de manera indistinta para referirse al fabricante. "Este equipo ha sido diseñado para operar con las antenas tipo Omnidireccional para una ganancia máxima de antena de 6 dBd y Yagi para una ganancia máxima de antena 10 dBd que en seguida se enlistan. También se incluyen aquellas con aprobación ATEX tipo Omnidireccional siempre que no excedan una ganancia máxima de antena de 6dBd. El uso con este equipo de antenas no incluidas en esta lista o que tengan una ganancia mayor que 6 dBd en tipo omnidireccional y 10 dBd en tipo Yagi, quedan prohibidas. La impedancia requerida de la antena es de 50 ohms."

Approved Antennas

BWA-9O2-C--Antena, Omni 902-928 MHz, 2 dBd, junta de caucho, RP-SMA Macho
BWA-9O5-C--Antena, Omni 902-928 MHz, 5 dBd, junta de caucho, RP-SMA Macho
BWA-9O6-A--Antena, Omni 902-928 MHz, 6 dBd, fibra de vidrio, 1800mm, N Hembra
BWA-9Y10-A--Antena, Yagi, 900 MHz, 10 dBd, N Hembra

Mexican Importer

Banner Engineering de México, S. de R.L. de C.V. | David Alfaro Siqueiros 103 Piso 2 Valle oriente | San Pedro Garza Garcia Nuevo León, C. P. 66269

81 8363.2714

Document title: Asset Monitoring Gateway with Cloud ID Quick Start Guide

Part number: 236146

Revision: B

Original Instructions

© Banner Engineering Corp. All rights reserved.

