

QM30VT3 Vibration Sensors

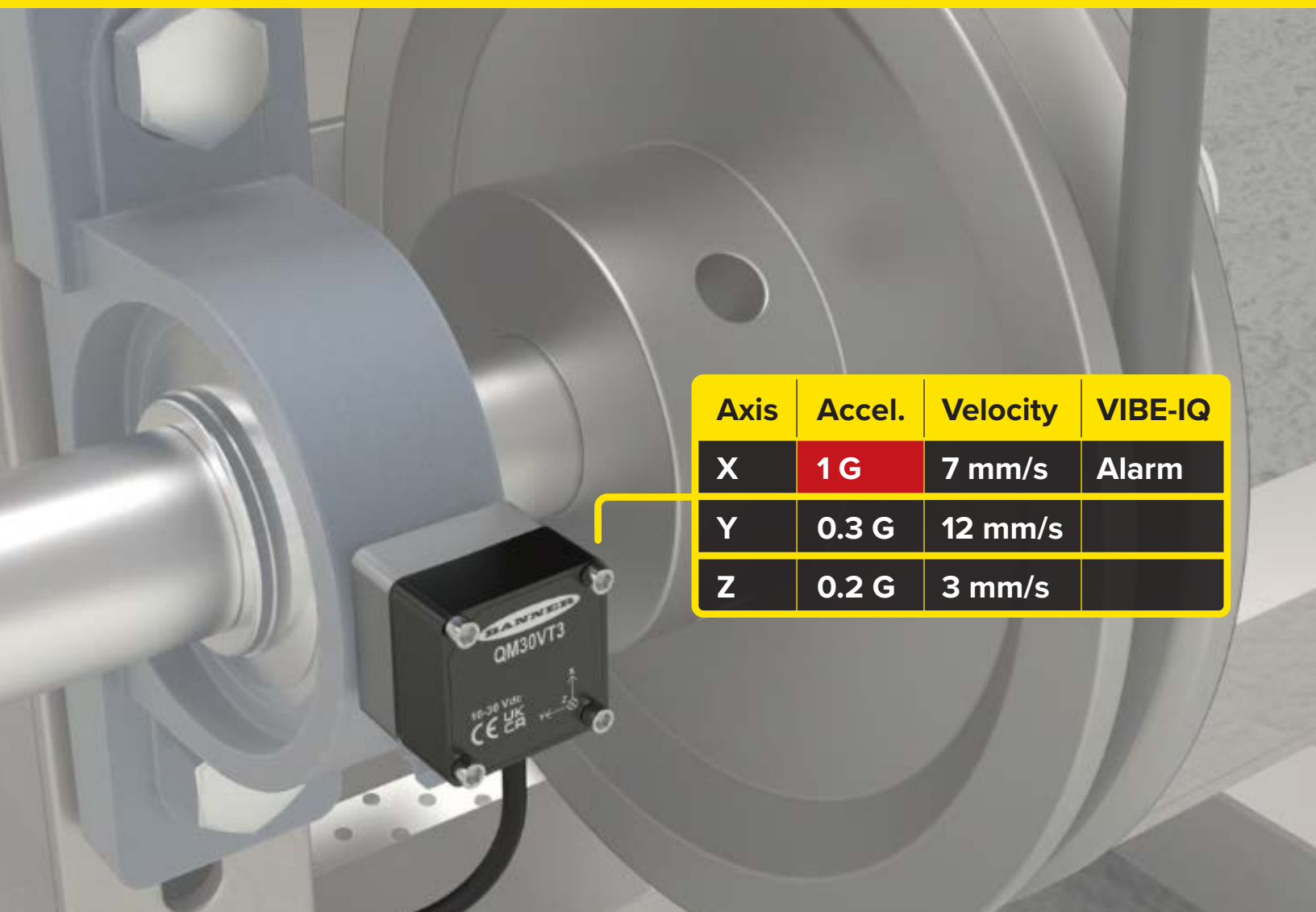

Axis	Accel.	Velocity	VIBE-IQ
X	1 G	7 mm/s	Alarm
Y	0.3 G	12 mm/s	
Z	0.2 G	3 mm/s	

High-Performance 3-Axis Vibration Sensors

- **VIBE-IQ®:** Built-in machine learning detects vibration baselines and generates warning and alarm thresholds so anyone can monitor assets—no gateway or expertise required
- **High-Frequency Enveloping (HFE):** Also known as demodulation mode, HFE detects early-stage low-amplitude, high-frequency faults like bearing and race wear, which are often masked by dominant low-frequency vibrations
- **Wide Frequency Range:** Detect more faults, from shaft misalignment in conveyor motors to gear mesh impacts in high-speed gearboxes
- **High-Speed Sampling:** Higher sample rates capture finer vibration details, improving early fault detection across a wide range of assets
- **Frequency Max (Fmax):** Balance frequency range and resolution to zoom in on low-frequency faults like pulley drive misalignment or monitor the full range at default resolution



Total Vibration Coverage, Smarter Predictive Maintenance, Flexible Installation

The QM30VT3 High-Performance 3-Axis Vibration Sensor delivers the real-time data and alerts that keep maintenance teams one step ahead of downtime. With ultra-low noise vibration monitoring on all three axes, automated baselines and alerts from onboard VIBE-IQ, wired and wireless options, and specialized capabilities like High-Frequency Enveloping (HFE) and adjustable FMax, it provides a flexible solution for teams across industries, equipment types, and maintenance applications.

3-Axis for Complete Coverage, Deeper Diagnostics, and Flexible Mounting

Ultra-low noise vibration monitoring on all three axes—X, Y, and Z—ensures a more complete view of machine health and greater installation flexibility compared to 2-axis sensors and most 3-axis MEMS sensors, which have up to three times more noise on their third axis. The QM30VT3 delivers ultra-low noise performance across all three axes, capturing vibration patterns that indicate critical early-stage faults that others miss, including shaft misalignment and rotational imbalance. Understanding how the sensor's axes correspond to the machine's axes allows you to mount it in the orientation that fits the application, detecting everything from subtle imbalance to early-stage bearing wear—regardless of orientation or mounting position.

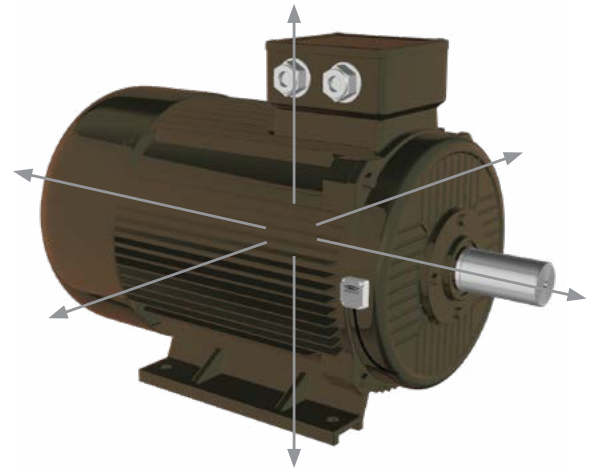

VIBE-IQ® Takes the Complexity out of Vibration Monitoring

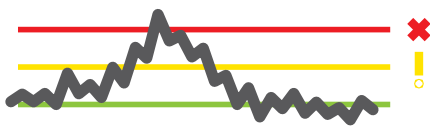

Built-in VIBE-IQ vibration monitoring software runs directly on the QM30VT3 sensor, using machine learning to establish baselines, set warning and alarm thresholds, and detect changes in vibration across all three axes. By continuously monitoring assets like motors and gearboxes, it provides early fault detection without requiring specialized manual setup or external processing, simplifying predictive maintenance and making it accessible to teams at every level of experience.

Advanced Features

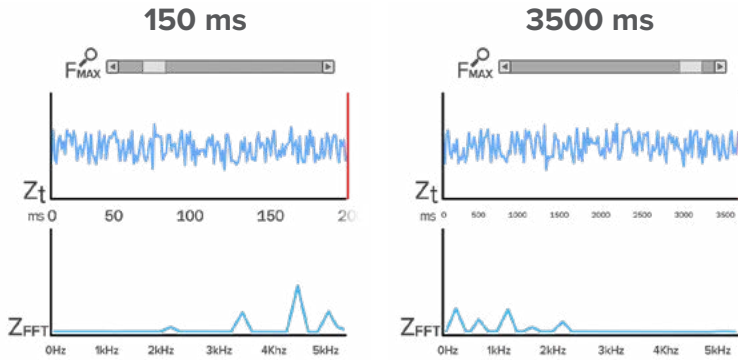

The QM30VT3 offers advanced tools like adjustable Frequency Max (F_{MAX}) and High-Frequency Enveloping mode (HFE) for applications requiring in-depth vibration analysis. Adjusting F_{MAX} lets users tailor the frequency range and sample length to machine speed and fault characteristics. Higher F_{MAX} captures a broad frequency range, using shorter sample times and default resolution suitable for detecting faults

in high-speed assets. Lower F_{MAX} values provide progressively finer sample resolution and longer sampling times for detecting faults in very slowly rotating equipment. HFE isolates high-frequency signals by filtering out low frequencies, making it easier to detect early-stage faults like bearing wear and lubrication issues. Combining HFE with a lower F_{MAX} setting extends sampling time and improves resolution while isolating high frequencies, which is critical for detecting weak high-frequency fault signatures in slow-speed assets otherwise masked by dominant low-frequency vibrations.

If you're interested in learning more about the QM30VT3's advanced features, contact a Banner representative.

Banner Can Scale to Any Predictive Maintenance Application

Whether you're just looking for one sensor or need help building a complete monitoring solution, Banner has the products and expertise you need to achieve your goals. Our plug and play systems offer both wired and wireless architectures to meet the needs of any installation. Here are two examples of systems, one based on a hard-wired RS-485 network, and the other on a Banner wireless network.

System Example: Modbus RS-485

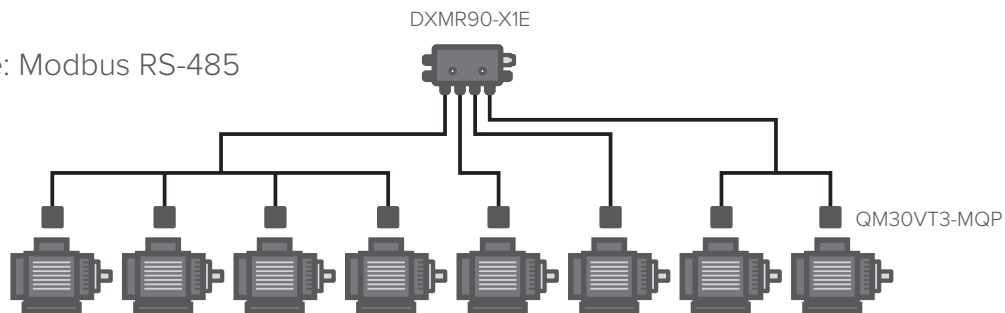

System Example: Banner Wireless

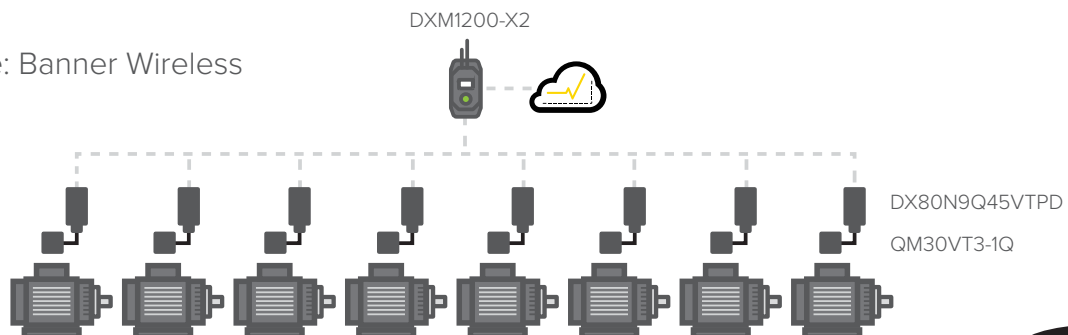

QM30VT3 Vibration and Temperature Sensors

Description	Housing	Connection	Models
Vibration and temperature via RS-485 Modbus	Aluminum	150 mm cable with 5-pin M12 male QD	QM30VT3-MQP
	316L Stainless Steel		QM30VT3-SS-MQP
Vibration and temperature via 1-wire serial interface for use with Banner wireless radios	Aluminum	2 m (6 ft) cable with 5-pin M12 male QD	QM30VT3-1Q
	316L Stainless Steel		QM30VT3-SS-1Q

Specifications

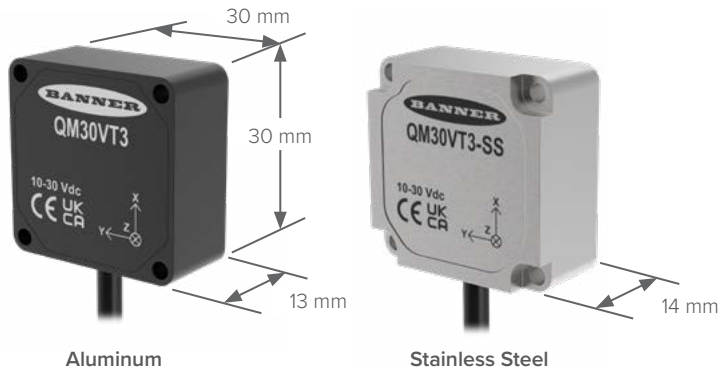

Supply Voltage

Modbus: 10 to 30 V DC
1-Wire Serial: 3.6 to 5.5 V DC

Vibration Sensor

Measurement range: 0 to 65.5 mm/s
Accuracy: ±10% at 25 °C

Temperature Sensor

Measurement range: -40 to +105 °C
Accuracy: ±4 °C

Operating Conditions

-40 to +105 °C

Environmental Rating

Aluminum: IP67
Stainless steel: IP69K

Certifications



Modbus Accessories



DXMR90-X1E
Wired Industrial Controller



R70SR9MQ
Cable-Replacement Radio for RS-485 Modbus Networks



DXM1200-X2
Wireless IIoT Gateway



BWA-UCT-900
RS-485 to USB Programming Cable



4-Pin M12 Double-Ended
Straight connector models

BC-M12F4-M12M4-22-2
2 m (6.5')
BC-M12F4-M12M4-22-5
5 m (16.4')
BC-M12F4-M12M4-22-10
10 m (32.8')

Banner Wireless Accessories



DX80N9Q45VTPD (900 MHz)
DX80N2Q45VTPD (2.4 GHz)
Wireless Node



DXM1200-X2R1 (900 MHz)
DXM1200-X2R3 (2.4 GHz)
Wireless IIoT Gateway



BWA-USB1WIRE-001
1-Wire Serial to USB Programming Cable



5-Pin M12 Double-Ended
Straight connector models

BC-M12F5-M12M5-22-2
2 m (6.5')
BC-M12F5-M12M5-22-5
5 m (16.4')
BC-M12F5-M12M5-22-10
10 m (32.8')

Brackets

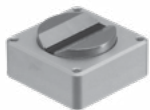

BWA-QM30-CMAL
Curved surface magnet mount

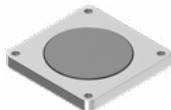

BWA-QM30-FMSS
Flat surface magnet mount



BWA-QM30-FSALR
Flat surface screw mount



BWA-QM30-FSSSR
Stainless steel flat surface screw mount



BWA-QM30CAB-MAG
Attaches to QM30 sensor cable (magnetic, pack of 10)



BWA-M12CAB-MAG
Attaches to M12 cable (magnetic, pack of 10)



Banner Engineering Corp.

1-888-373-6767 • www.bannerengineering.com

© 2025 Banner Engineering Corp. Minneapolis, MN USA

PN B_51937477