

## Features

- Monitors one or two safety switches for a contact failure or wiring fault
- Two output switching channels for connection to control-reliable power interrupt circuits
- Auto reset or monitored manual reset
- Design complies with standards UL991, ISO 14119, and EN ISO 13849-1 (Safety Category 2, 3 or 4)
- For use in functional stop category 0 applications per NFPA 79 and IEC 60204-1
- 6 amp safety output contacts
- Removable terminal blocks
- If terminal blocks are swapped, Module remains functional with no loss of safety function
- 24 V AC/DC operation
- Single- or dual-channel input monitoring



## GM-FA-10J Overview

The GM-FA-10J Gate Monitor Safety Module (the "Safety Module") is used to verify the proper operation of coded magnetic safety switches and positive-opening safety switches by monitoring a normally open (N.O.) and a normally closed (N.C.) contact from each switch. It can also be used to monitor and verify the correct state of two redundant current-sourcing PNP signals. (One PNP source must be Normally OFF and the other Normally Conducting for each input channel.) In a typical application, two safety switches (individually mounted) indicate the open or closed status of a gate, moveable guard, or barrier (all called "guards" throughout this document).

Two functions of the Safety Module are:

1. To monitor the contacts and wiring of safety switches for certain failures and to prevent the machine from restarting if the switch or the Module fails, and
2. To provide a reset routine after closing the guard and returning the inputs to their "closed" condition. This reset function may be required by machine safety standards.

The Safety Module monitors each switch for complementary switching: **each channel must have one open (OFF) input and one closed (conducting) input at all times**. These inputs must always be in opposite states and must switch state within 1 second of each other. Channel 1 has a "guard closed" condition when S11/S13 is closed and S11/S12 is open. Similarly, Channel 2 has a "guard closed" condition when S21/S23 is closed and S21/S22 is open (see "Figure: Wiring to two 4-wire coded magnetic safety switches. Configured for single-channel monitoring of either one or two guards (jumper S11/S13 or S21/S23 for single-channel), this application is considered to meet or exceed requirements for Control Reliability and Safety Categories 3 and 4 per EN ISO 13849-1. on page 5 and "Figure: Wiring to two positive-opening safety interlock switches. Configured for dual-channel monitoring of one guard, this application is considered to meet or exceed requirements for Control Reliability and Safety Categories 3 and 4 per EN ISO 13849-1. on page 5). The Safety Module also will detect and properly respond to a short circuit between the channels and a short circuit to other sources of power. The Safety Module will open the safety outputs within 35 milliseconds of the switching of either channel when the guard opens.

When the guard closes, debounce logic in the Safety Module's inputs increases the reliability and repeatability of successfully resetting the Safety Module and reduces the necessity of re-cycling the guard. This feature can result in increased efficiency of the machine, even if the guard is misaligned or vibration is present.

### Important: Read This First!

**The user is responsible for satisfying all local, state, and national laws, rules, codes, and regulations** relating to the use of this product and its application. Banner Engineering Corp. has made every effort to provide complete application, installation, operation, and maintenance instructions. Please contact a Banner Applications Engineer with any questions regarding this product.

**The user is responsible** for making sure that all machine operators, maintenance personnel, electricians, and supervisors are thoroughly familiar with and understand all instructions regarding the installation, maintenance, and use of this product, and with the machinery it controls. The user and any personnel involved with the installation and use of this product must be thoroughly familiar with all applicable standards, some of which are listed within the specifications. Banner Engineering Corp. makes no claim regarding a specific recommendation of any organization, the accuracy or effectiveness of any information provided, or the appropriateness of the provided information for a specific application.

#### Applicable U.S. Standards

ANSI B11 Standards for Machine Tools Safety

Contact: Safety Director, AMT – The Association for Manufacturing Technology, 7901 Jones Branch Drive, Suite 900, McLean, VA 22102-4206 USA, [www.amtonline.org](http://www.amtonline.org)

NFPA 79 Electrical Standard for Industrial Machinery

Contact: National Fire Protection Association, 1 Batterymarch Park, Quincy, MA 02169-7471 USA, [www.nfpa.org/](http://www.nfpa.org/)

ANSI/RIA R15.06 Safety Requirements for Industrial Robots and Robot Systems

Contact: Robotic Industries Association, 900 Victors Way, Suite 140, Ann Arbor, MI 48108 USA, [www.robotics.org](http://www.robotics.org)

#### Applicable International Standards

ISO 12100 Safety of Machinery – General Principles for Design – Risk Assessment and Risk Reduction

EN 60204-1 Electrical Equipment of Machines Part 1: General Requirements

ISO 13849-1 Safety of Machinery – Safety-Related Parts of Control Systems – Part 1: General Principles for Design

EN 13855 (EN 999) The Positioning of Protective Equipment in Respect to Approach Speeds of Parts of the Human Body

ISO 14119 (EN 1088) Interlocking Devices Associated with Guards – Principles for Design and Selection

Also, request a type "C" standard for your specific machinery.

Contact: IHS Markit (Global Engineering Documents), 15 Inverness Way East, Englewood, CO 80112 USA, <https://global.ihs.com/>

#### Certificate of Adequacy

This Safety Module datasheet (p/n 60998) satisfies the requirements of Machinery Directive 2006/42/EC, Section 1.7.4 — instructions.

### Safety Circuit Integrity and EN ISO 13849-1 Safety Circuit Principles

Safety circuits involve the safety-related functions of a machine that minimize the level of risk of harm. These safety-related functions can prevent initiation, or they can stop or remove a hazard. The failure of a safety-related function or its associated safety circuit usually results in an increased risk of harm.

The integrity of a safety circuit depends on several factors, including fault tolerance, risk reduction, reliable and well-tried components, well-tried safety principles, and other design considerations.

Depending on the level of risk associated with the machine or its operation, an appropriate level of safety circuit integrity (performance) must be incorporated into its design. Standards that detail safety performance levels include ANSI B11.19 Performance Criteria for Safeguarding and EN ISO 13849-1 Safety-Related Parts of a Control System.

### Safety Circuit Integrity Levels

Safety circuits in International and European standards have been segmented into categories, depending on their ability to maintain their integrity in the event of a failure. The most recognized standard that details safety circuit integrity levels is EN ISO 13849-1, which establishes five levels: Categories B, 1, 2, 3, and the most stringent, Category 4.

In the United States, the typical level of safety circuit integrity has been called control reliability. Control reliability typically incorporates redundant control and self-checking circuitry and has been loosely equated to EN ISO 13849-1 Categories 3 and 4 (see CSA Z432 and ANSI B11.TR4).

If the requirements described by EN ISO 13849-1 are to be implemented, a risk assessment must first be performed to determine the appropriate category, in order to ensure that the expected risk reduction is achieved. This risk assessment must also take into account national regulations, such as U.S. control reliability or European "C" level standards, to ensure that the minimum level of performance that has been mandated is complied with.

### Fault Exclusion

An important concept within the category requirements of EN ISO 13849-1 is the probability of the occurrence of the failure, which can be decreased using the "fault exclusion" method. This method assumes that the possibility of certain well-defined failure(s) can be reduced to a point where the resulting fault(s) can be disregarded.

**Fault exclusion** is a tool a designer can use during the development of the safety-related part of the control system and the risk assessment process. It allows the designer to eliminate the possibility of various failures and justify it through the risk assessment process to meet the requirements of Categories 2, 3, or 4. See EN ISO 13849-1/2 for further information.

### Configuration

The Safety Module may be configured via DIP switches for dual-channel (redundant switches on a single guard), or single-channel operation (individual switches on two guards). **In dual-channel operation, each channel (S11/S12/S13 and S21/S22/S23) must switch within 3-second simultaneity of the other when the guard closes.** If not, the guard must be re-opened and closed until the timing requirement is met. When the guard opens, the two channels operate concurrently (both channels must switch but without the timing requirement).

**In single-channel operation, each channel operates individually,** except to reset the device (in which case both guards must be closed). If only one switch is being monitored, the closed input of the unused channel must be jumpered (S11/S13 or S21/S23).

The reset function has two options, selected by DIP switch: Automatic reset or Monitored Manual reset. See "Figure: Wiring to the guarded machine on page 6" for configuration information.

The reset input also can be used for an External Device Monitoring (EDM) circuit. The EDM circuit consists of a normally closed, force-guided contact from each device being controlled by the Safety Module, all wired in series with the Reset button (if used) and terminated at terminals Y1 and Y2. See "Figure: Alternate wiring for dual-channel monitoring of multiple guards on page 6" for further information.

The output of the Safety Module consists of two redundant output switching channels, each of which is the series connection of two forced-guided relay contacts (K1 and K2 in "Figure: Alternate wiring for dual-channel monitoring of multiple guards on page 6"). Each of the switching outputs is rated for up to 250 V AC at up to 6 amps.

GM-FA-10J Features and Terminal Locations

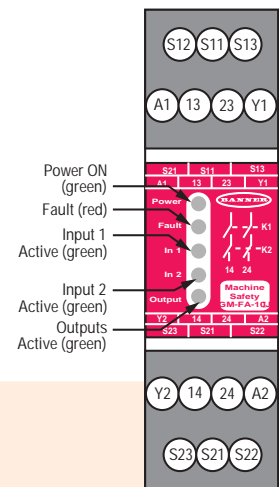

#### WARNING:



- The hazard must be accessible only through the sensing field
- Incorrect system installation could result in serious injury or death.
- The installation of the Safety Module must prevent any individual from reaching around, under, over or through the defined area and into the hazard without being detected.
- See OSHA CFR 1910.217, ANSI B11.19, and/or ISO 14119, ISO 14120 and ISO 13857 for information on determining safety distances and safe opening sizes for your guarding device. Mechanical barriers (for example, hard (fixed) guarding) or supplemental safeguarding might be required to comply with these requirements.

#### WARNING:



- Determine the safety category
- The design and installation of the safety devices and the means of interfacing of those devices could greatly affect the level of safety circuit integrity.
- Perform a risk assessment to determine the appropriate safety circuit integrity level or safety category, as described by ISO 13849-1, to ensure that the expected risk reduction is achieved and that all applicable regulations and standards are met.

### Safety Interlock Switch Requirements

The following general requirements and considerations apply to the installation of interlocked guards and gates for the purpose of safeguarding. In addition, the user must refer to the relevant regulations to ensure compliance with all necessary requirements.

Hazards guarded by the interlocked guard must be prevented from operating until the guard is closed; a stop command must be issued to the guarded machine if the guard opens while the hazard is present. Closing the guard must not, by itself, initiate hazardous motion; a separate procedure must be required to initiate the motion. The safety interlock switches must not be used as a mechanical or end-of-travel stop.

The guard must be located an adequate distance from the danger zone (so that the hazard has time to stop before the guard is opened sufficiently to provide access to the hazard), and it must open either laterally or away from the hazard, not into the safeguarded area. The guard also should not be able to close by itself and activate the interlocking circuitry. In addition, the installation must prevent personnel from reaching over, under, around, or through the guard to the hazard. Any openings in the guard must not allow access to the hazard (see OSHA 29CFR1910.217 Table O-10, ANSI B11.19, ISO 13857, EN ISO14120 or the appropriate standard). The guard must be strong enough to contain hazards within the guarded area, which may be ejected, dropped, or emitted by the machine.

The safety interlock switches, actuators, sensors, and magnets must be designed and installed so that they cannot be easily defeated. They must be mounted securely so that their physical position cannot shift, using reliable fasteners that require a tool to remove them. Mounting slots in the housings are for initial adjustment only; final mounting holes must be used for permanent location.



**WARNING:** If the application could result in a pass-through hazard (for example, perimeter guarding), either the safeguarding device or the guarded machine's MSCs/MPCEs must cause a Latched response following a Stop command (for example, interruption of the sensing field of a light curtain, or opening of an interlocked gate/guard). The reset of this Latched condition may only be achieved by actuating a reset switch that is separate from the normal means of machine cycle initiation. The switch must be positioned as described in this document.



**WARNING:**

- **Perimeter guarding applications**
- Failure to observe this warning could result in serious injury or death.
- Use lockout/tagout procedures per ANSI Z244.1, or use additional safeguarding as described by ANSI B11.19 safety requirements or other applicable standards if a passthrough hazard cannot be eliminated or reduced to an acceptable level of risk.

#### Coded Magnetic Safety Switches

Similar to positive-opening safety switches, coded magnetic switches used with the Safety Module must provide one normally closed contact and one normally open contact (typically a four-wire switch). The sensor and its magnet must be mounted a minimum distance of 15 mm (0.6 inches) from any magnetized or ferrous materials for proper operation. If either the sensor or magnet is mounted on a material that can be magnetized (a ferrous metal, such as iron), the switching distance will be affected. Although the sensor and magnet are coded to minimize the possibility of false actuation, they should not be used within known fields of high-level electromagnetic radiation.

Depending on the model of sensor and magnet used, the installation must be designed to provide the correct direction of approach. The speed of approach must be fast enough to meet the simultaneity-monitoring period of 1.0 second, approximately equal to or greater than 0.1 m (4 inches) per second. If the simultaneity requirement is not met, the Safety Module can not be reset and will not close its safety output contacts.

#### Positive-Opening Interlocking Switches

Safety interlock switches used with the Safety Module must satisfy several requirements. Each switch must provide electrically isolated contacts: at minimum, one normally closed (N.C.) contact or normally conducting source and one normally open (N.O.) contact or normally OFF source to interface with the Module.

The contacts must be of "positive-opening" design, with one or more normally closed contacts rated for safety. Positive-opening operation causes the switch to be forced open, without the use of springs, when the switch actuator is disengaged or moved from its home position (see the Banner Catalog for examples). In addition, the switches must be mounted in a "positive mode," to move/disengage the actuator from its home position and open the normally closed contact, when the guard opens.

#### Switch Wiring for Typical Applications

Requirements vary widely for the level of control reliability or safety category (per EN ISO 13849) in the application of interlocked guards. Although Banner Engineering always recommends the highest level of safety in any application, it is the user's responsibility to safely install, operate, and maintain each safety system and comply with all relevant laws and regulations. The applications shown in ["Figure: Wiring to two 4-wire coded magnetic safety switches. Configured for single-channel monitoring of either one or two guards \(jumper S11/S13 or S21/S23 for single-channel\), this application is considered to meet or exceed requirements for Control Reliability and Safety Categories 3 and 4 per EN ISO 13849-1. on page 5 through "Figure: Wiring to two complementary current-sourcing PNP devices. Configured for either single-channel or dual-channel monitoring, the level of safety \(Control Reliability or Safety Categories\) is dependent on the devices connected to the GM-FA-10J. on page 4 meet or exceed the requirements for control reliability and Safety Category 3 or 4, per EN ISO 13849.](#)

## Mechanical Installation

The Safety Module must be installed inside an enclosure.

It is not designed for exposed wiring. It is the user's responsibility to house the Safety Module in an enclosure with NEMA 3 (IEC IP54) rating, or better. The Safety Module mounts directly to standard 35 mm DIN rail.

**Heat Dissipation Considerations:** For reliable operation, ensure that the operating specifications are not exceeded. The enclosure must provide adequate heat dissipation so that the air closely surrounding the Safety Module does not exceed the maximum operating temperature stated in the Specifications. Methods to reduce heat build-up include venting, forced airflow (for example, exhaust fans), adequate enclosure exterior surface area, and spacing between modules and other heat sources.

## Electrical Installation

Each Safety Module is powered by 24 V AC/DC (at less than 150 mA). The Safety Module, in turn, supplies power to each switch.

It is not possible to give exact wiring instructions for a Safety Module that interfaces to a multitude of machine control configurations. The following guidelines are general in nature.

The Safety Module has no delay function. Its output relay contacts open within **35 milliseconds** after a safety input opens. This classifies the Safety Module as a functional stop "Category 0" control, as defined by NFPA 79 and IEC/EN 60204-1.



**WARNING:**

- **Risk of electric shock**
- Use extreme caution to avoid electrical shock. Serious injury or death could result.
- Always disconnect power from the safety system (for example, device, module, interfacing, etc.), guarded machine, and/or the machine being controlled before making any connections or replacing any component. Lockout/tagout procedures might be required. Refer to OSHA 29CFR1910.147, ANSI Z244-1, or the applicable standard for controlling hazardous energy.
- Make no more connections to the device or system than are described in this manual. Electrical installation and wiring must be made by a Qualified Person<sup>(1)</sup> and must comply with the applicable electrical standards and wiring codes, such as the NEC (National Electrical Code), NFPA 79, or IEC 60204-1, and all applicable local standards and codes.

### Connecting Power to the Safety Module

The Safety Module requires a 24 V AC/DC supply voltage (see ["GM-FA-10J Specifications" on page 10](#)). Use extreme caution when installing AC power. Use a minimum of 16 AWG wire for power and output connections. Use a minimum of 20 AWG wire for all other terminal connections. A hand-operated supply disconnect and over-current protection (for example, a circuit breaker) must be provided per ANSI NFPA79 and IEC/EN60204-1.

### Monitoring Series-Connected Safety Switches

When monitoring two individually mounted safety switches (as shown in ["Figure: Wiring to two 4-wire coded magnetic safety switches. Configured for single-channel monitoring of either one or two guards \(jumper S11/S13 or S21/S23 for single-channel\), this application is considered to meet or exceed requirements for Control Reliability and Safety Categories 3 and 4 per EN ISO 13849-1. on page 5 through "Figure: Wiring to two complementary current-sourcing PNP devices. Configured for either single-channel or dual-channel monitoring, the level of safety \(Control Reliability or Safety Categories\) is dependent on the devices connected to the GM-FA-10J. on page 4](#)), a faulty switch will be detected if it fails to switch as the guard opens. In this case, the Gate Monitor Module will de-energize its output relays and disable its reset function until the input requirements are met (i.e., the faulty switch is replaced). However, when a series of interlocking safety switches is monitored by a single Safety Module, the failure of one switch in the system may be masked or not detected at all (refer to ["Figure: Alternate wiring for single-channel monitoring of multiple guards on page 5 and "Figure: Alternate wiring for dual-channel monitoring of multiple guards on page 6](#)).

<sup>(1)</sup> A person who, by possession of a recognized degree or certificate of professional training, or who, by extensive knowledge, training and experience, has successfully demonstrated the ability to solve problems relating to the subject matter and work.

Series-connected interlock switch circuits do not meet EN ISO 13849 Safety Category 4 and may not meet Control Reliability requirements because of the potential for an inappropriate Gate Monitor reset or a potential loss of the safety stop signal. A multiple connection of this type should not be used in applications where loss of the safety stop signal or an inappropriate reset can lead potentially to serious injury or death. The following two scenarios assume two positive-opening safety switches on each guard:

- 1. Masking of a failure.** If a guard is opened but a switch fails to open, the redundant safety switch will open and cause the Safety Module to de-energize its outputs. If the faulty guard is then closed, both Safety Module input channels also close, but because one channel did not open, the Safety Module will not reset. However, if the faulty switch is not replaced and a second "good" guard is cycled (opening and then closing both of the Module's input channels), the Module considers the failure to be corrected. With the input requirements apparently satisfied, the Module allows a reset. This system is no longer redundant and, if the second switch fails, may result in an unsafe condition (i.e., the accumulation of faults results in the loss of the safety function).
- 2. Non-detection of a failure.** If a good guard is opened, the Safety Module de-energizes its outputs (a normal response). But if a faulty guard is then opened and closed before the good guard is re-closed, the failure on the faulty guard is not detected. This system is no longer redundant and may result in a loss of safety if the second safety switch fails to switch when needed.

The systems in either scenario do not inherently comply with the safety standard requirements of detecting single faults and preventing the next cycle. In multiple-guard systems using series-connected safety switches, it is important to periodically check the functional integrity of each interlocked guard individually. Operators, maintenance personnel, and others associated with the operation of the machine must be trained to recognize such failures and be instructed to correct them immediately.

Open and close each guard separately while verifying that the Gate Monitor outputs operate correctly throughout the check procedure. Follow each gate closure with a manual reset, if needed. If a contact set fails, the Safety Module will not enable its reset function. If the Safety Module does not reset, a switch may have failed; that switch must be immediately replaced.

This check must be performed and all faults must be cleared, at a minimum, during periodic checkouts. If the application can not exclude these types of failures and such a failure could result in serious injury or death, then the series connection of safety switches must not be used.



**WARNING:**

- **Connect two or more devices to the same safety module (controller) in series**
- Connecting devices in parallel defeats the switch contact monitoring ability of the module and creates an unsafe condition that could result in serious injury or death.
- Failure to test each device individually in this manner could result in undetected faults and create an unsafe condition that could result in serious injury or death.
- Connect the contacts of the corresponding pole of each switch in series. Never connect the contacts of multiple switches in parallel. Individually actuate (engage) each device, then release (or re-arm) and reset the safety module. This allows the module to check each switch and its wiring to detect faults. Perform this check during the prescribed checkouts.

## Connecting to the Guarded Machine

The machine interface wiring diagram shows a generic connection of the Module's two redundant output circuits to machine primary control elements MPCE1 and MPCE2. A machine primary control element is an electrically powered device, external to the Module, which stops the guarded machinery by immediately removing electrical power to the machine and (when necessary) by applying braking to dangerous motion. The stop is accomplished by removing power to the actuator coil of either MPCE.

To satisfy the Safety Category 4 requirements of EN ISO 13849, each MPCE must offer a normally closed, forced-guided monitor contact. One normally closed monitor contact from each MPCE is wired in series to the Y1-Y2 feedback/reset input (see "Figure: Wiring to the guarded machine on page 6). In operation, if one of the switching contacts of either MPCE fails in the shorted condition, the associated monitor contact will remain open, preventing the reset of the Module.

## External Device Monitoring

To satisfy the requirements of Control Reliability (OSHA and ANSI) and Category 3 and 4 of EN ISO 13849-1, the machine primary control elements (MPCEs) must each offer a normally closed, forced-guided (mechanically linked) monitor contact. Connect one normally closed monitor contact from each master stop control element in series to Y1 and Y2 (see [Key definition for "ElectricalInstallation" not found in the DITA map.](#))

In operation, if one of the switching contacts of either MPCE fails in the energized condition, the associated monitor contact will remain open. Therefore, it will not be possible to reset the Safety Module. If no MPCE-monitor contacts are monitored, a jumper must be installed between terminals Y1 and Y2 (dotted line), as shown in the hookup drawings. **It is the user's responsibility to ensure that any single failure will not result in a hazardous condition and will prevent a successive machine cycle.**

## Connecting Safety Switches

*Wiring to two complementary current-sourcing PNP devices. Configured for either single-channel or dual-channel monitoring, the level of safety (Control Reliability or Safety Categories) is dependent on the devices connected to the GM-FA-10J.*

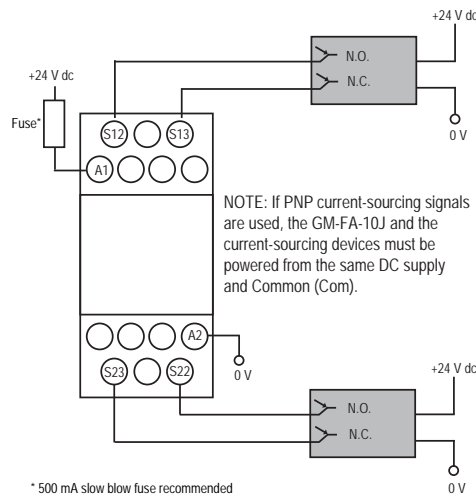

Wiring to two 4-wire coded magnetic safety switches. Configured for single-channel monitoring of either one or two guards (jumper S11/S13 or S21/S23 for single-channel), this application is considered to meet or exceed requirements for Control Reliability and Safety Categories 3 and 4 per EN ISO 13849-1.

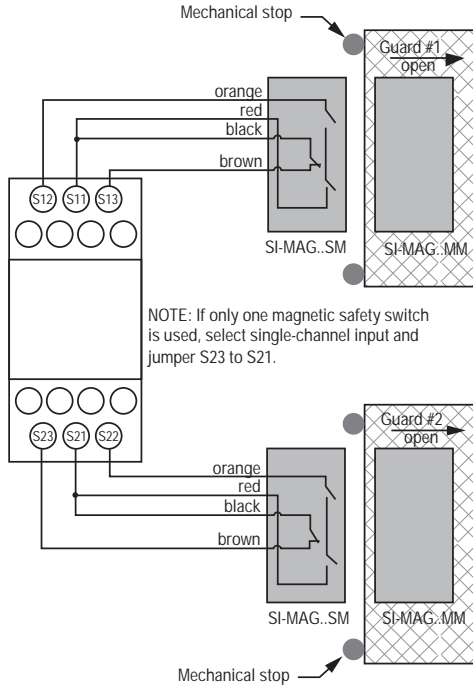

Wiring to two positive-opening safety interlock switches. Configured for dual-channel monitoring of one guard, this application is considered to meet or exceed requirements for Control Reliability and Safety Categories 3 and 4 per EN ISO 13849-1.

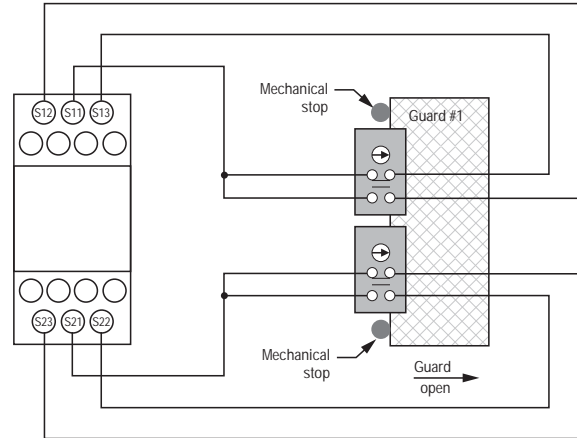

**IMPORTANT:** If the model number of the magnetic switch does not include a letter between the SI-MAG and the number, the orange wire shown is blue and the red wire is gray (older models).

### Single-Channel Monitoring

Alternate wiring for single-channel monitoring of multiple guards

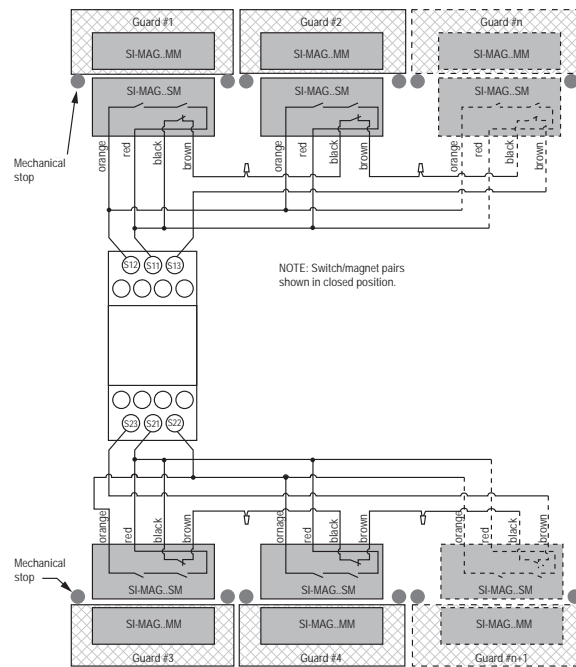

Configured for single-channel monitoring of multiple guards with single switches at each guard (see Warning). Up to 10 Banner magnetic switches may be connected to each channel in this series/parallel method.



**WARNING: Not a Safety Category 4 Application.** When monitoring multiple guards with a series connection of multiple safety interlock switches, a single failure may be masked or not detected at all. When such a configuration is used, procedures must be performed regularly to verify proper operation of each switch. See "Monitoring Series- Connected Safety Switches" for more information.

(If other than Banner magnetic switches are used, a total resistance of 270 Ohms between S11/S13, S11/S12, S21/S22, and S21/S23 must not be exceeded.)

**IMPORTANT:** If the model number of the magnetic switch does not include a letter between the SI-MAG and the number, the orange wire shown is blue and the red wire is gray (older models).

**IMPORTANT:** The single- and dual-channel monitoring is referring to the module's input channels not to generic safety circuits. Each input channel of the module is monitoring the changes of two input contacts and can be used in circuits rated to the highest levels of safety.

Dual-Channel Monitoring

Configured for dual-channel monitoring of multiple guards with two safety switches mounted individually on each guard (see Warning).

The number of mechanical switches is limited by the max. resistance of 270 ohm between S11/S13, S11/S12, S21/S22 and S21/S23. The total resistance is calculated by adding the resistance of all guard switch contacts and the resistance of the cables that connect the switches and the switches to the module.

**WARNING: Not a Safety Category 4 Application.** When monitoring multiple guards with a series connection of multiple safety interlock switches, a single failure may be masked or not detected at all. When such a configuration is used, procedures must be performed regularly to verify proper operation of each switch. See "Monitoring Series- Connected Safety Switches" for more information.

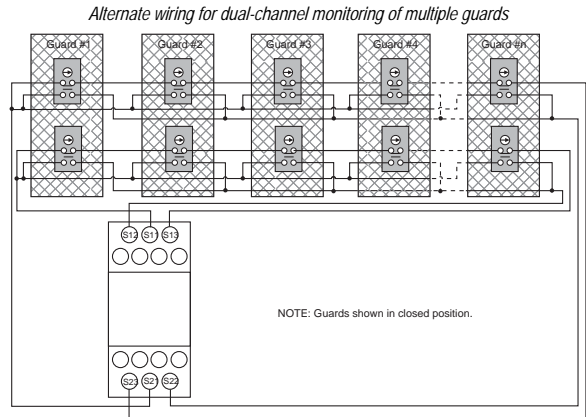

**WARNING: Interfacing MPCEs.** NEVER wire an intermediate device(s) (e.g., PLC, PES, PC), between the Safety Module outputs and the machine primary control element (MPCe) it switches, in such a manner that in the event of a failure there is the loss of the safety stop command, OR in such a manner that the safety function can be suspended, overridden, or defeated, unless accomplished with the same or greater degree of safety. Whenever forced-guided, mechanically linked relays are added as intermediate switching devices, a normally closed forced-guided monitor contact from each relay must be added to the series feedback loop between Safety Module terminals Y1 and Y2.

**WARNING:**

- Properly install arc or transient suppressors
- Failure to follow these instructions could result in serious injury or death.
- Install any suppressors as shown across the coils of the machine primary control elements. Do not install suppressors directly across the output contacts of the safety or interface module. In such a configuration, it is possible for suppressors to fail as a short circuit.

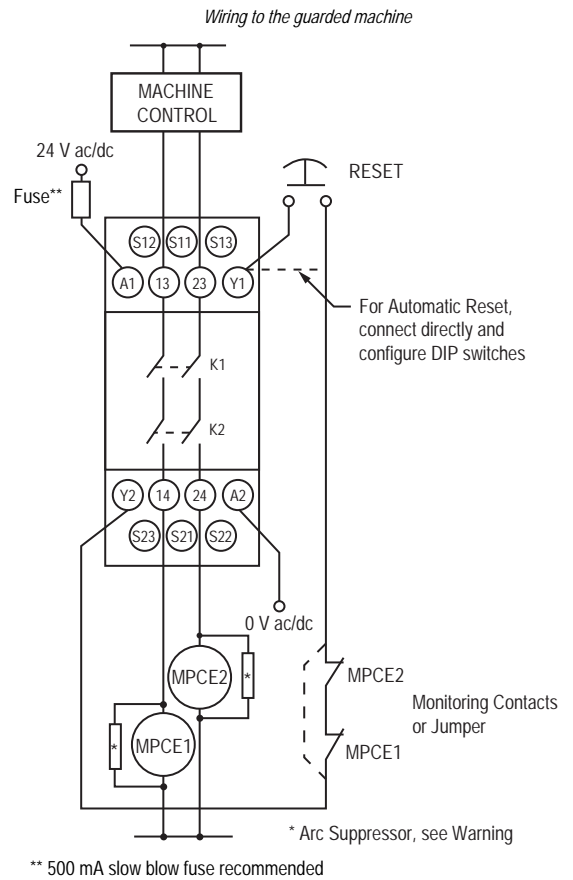

Overvoltage Category II and III Installations (EN 50178 and IEC 60664-1)

The Safety Module is rated for Overvoltage Category III when voltages of 1 V to 150 V AC/DC are applied to the output relay contacts. It is rated for Overvoltage Category II when voltages of 151 V to 250 V AC/DC are applied to the output relay contacts and no additional precautions are taken to attenuate possible overvoltage situations in the supply voltage. The Safety Module can be used in an Overvoltage Category III environment (with voltages of 151 V to 250 V AC/DC) if care is taken either to reduce the level of electrical disturbances seen by the Safety Module to Overvoltage Category II levels by installing surge suppressor devices (for example, arc suppressors), or to install extra external insulation in order to isolate both the Safety Module and the user from the higher voltage levels of a Category III environment.

**For Overvoltage Category III installations with applied voltages from 151 V to 250 V AC/DC applied to the output contact(s):** the Safety Module may be used under the conditions of a higher overvoltage category where appropriate overvoltage reduction is provided. Appropriate methods include:

- An overvoltage protective device
- A transformer with isolated windings

- A distribution system with multiple branch circuits (capable of diverting energy of surges)
- A capacitance capable of absorbing energy of surges
- A resistance or similar damping device capable of dissipating the energy of surges

When switching inductive AC loads, it is good practice to protect the Safety Module outputs by installing appropriately-sized arc suppressors. However, if arc suppressors are used, they must be installed across the load being switched (for example, across the coils of external safety relays), and never across the Safety Module's output contacts.

## GM-FA-10J Configuration



**WARNING:**

- **Reset routine required**
- Failure to prevent the machine from restarting without actuating the normal start command/device can create an unsafe condition that could result in serious injury or death.
- Do not allow the machine to restart without actuating the normal start command/device. Perform the reset routine after clearing the cause of a stop condition, as required by U.S. and international standards.



**WARNING:**

- **Install reset switches properly**
- Failure to properly install reset switches could result in serious injury or death.
- Install reset switches so that they are accessible only from outside, and in full view of, the safeguarded space. Reset switches cannot be accessible from within the safeguarded space. Protect reset switches against unauthorized or inadvertent operation (for example, through the use of rings or guards). If there are any hazardous areas that are not visible from the reset switches, provide additional safeguarding.

To remove a terminal block, insert a small flat-blade screwdriver into the slot at the center of the block as shown (may be covered by label). As typically mounted on a DIN rail, to remove the top block, rotate the screwdriver downwards (towards the module) and pry to loosen. The terminal block will slide outwards (towards you) as it loosens. To remove the lower block, rotate the screwdriver upwards (towards the module) and pry to loosen.

When reinserting the block, take care to slide the dovetail on the terminal block into the slot on the frame.

Removal of terminal blocks

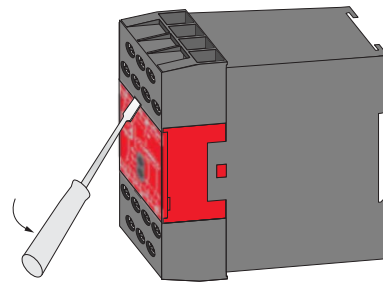

## Manual Reset and Reset Switch Connection

DIP switch configuration settings for reset mode and single- or dual-channel operation

The reset switch must be capable of reliably switching 15 to 30 V DC at 5 to 50 mA. As shown in "Figure: Wiring to the guarded machine on page 6, the reset switch connects between terminals Y1 and Y2 of the Module. The reset switch must be located outside of – and not accessible from – the area of dangerous motion, and it must be positioned so the switch operator can see all areas of dangerous motion during the reset procedure (see Warning).

To configure the Module for Manual Reset, set switches S1.2 and S2.2 in banks A and B to OFF (away from the board). The reset switch may be any mechanical normally open switch, but should be a momentary switch or a two-position keyed switch. To reset the Module, both guards must be closed, at which time the output LED will flash (signaling that the reset switch must be cycled). This action is a monitored manual reset (open-closed-open), where the "closed" phase is approximately 0.25 to 2 seconds long.

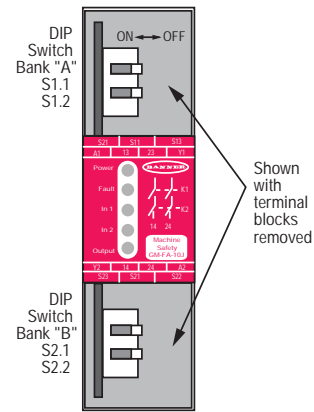

S1.1/S2.1 OFF\* – Dual-Channel  
ON – Single-Channel

S1.2/S2.2 OFF\* – Manual Reset  
ON – Auto Reset

\* Factory Default

NOTE: Corresponding DIP switches in Banks A and B must be set identically.

## Automatic Reset Mode

To configure the Module for Automatic Reset, set switches S1.2 and S2.2 in Banks A and B to ON. If no MPCE contacts are monitored, install a jumper between terminals Y1 and Y2 (see "Figure: Wiring to the guarded machine on page 6). The Safety Module will reset (and its outputs will energize) as soon as the guards return to their closed position.

Automatic Reset is useful for some automated processes. However, if Automatic Reset is used, an alternate means must be provided to prevent resumption of hazardous machine motion until an alternate reset procedure is performed. The alternate means must include a Reset switch, located outside the area of dangerous motion, and positioned so that the switch operator can see all areas of dangerous motion during the reset procedure.

## Single-Channel or Dual-Channel Input

The Safety Module may be configured for single-channel or dual-channel operation by setting DIP switches S1.1 and S2.1 in Banks A and B. In single-channel operation (S1.1 and S2.1 – ON), the input channels function independently. The two guards can be monitored individually, but both channels must be in the closed position for the Safety Module to be reset.

In dual-channel operation (S1.1 and S2.1 – OFF) the input channels must function together. Both channels must switch within a 3-second simultaneity of the other when the guard closes. If not, the guard must be re-opened and closed until the timing requirement is met. When the guard opens, the channels function concurrently (both must open, but without the timing requirement).

In either configuration, the “closed” inputs of each channel must be closed before the Safety Module can be reset (continuity S11 to S13 and S21 to S23). If in single-channel mode and monitoring only one switch, a jumper must be installed at the unused input (e.g., S21 to S23; see ["Figure: Wiring to two 4-wire coded magnetic safety switches. Configured for single-channel monitoring of either one or two guards \(jumper S11/S13 or S21/S23 for single-channel\), this application is considered to meet or exceed requirements for Control Reliability and Safety Categories 3 and 4 per EN ISO 13849-1. on page 5\).](#)

## Troubleshooting

### Initial Checkout Procedure

**CAUTION:**

- **Disconnect power prior to checkout**
- Dangerous voltages might be present along the module wiring barriers whenever power to the machine control elements is on.
- Before performing the initial checkout procedure, disconnect all power from the machine to be controlled. Exercise extreme caution whenever machine control power is or might be present. Always disconnect power to the machine control elements before opening the enclosure housing of the module.

**WARNING:**

- **Test multiple safety devices individually**
- Failure to test each safety device individually could result in undetected faults and create an unsafe condition that could result in serious injury or death.
- When two or more safety devices are used, individually actuate each device, causing a stop or open-contact condition, then reset/rearm the safety module (if using manual reset mode). This allows the monitoring circuits to check each device and its wiring to detect faults.

1. Remove power from the machine primary control elements (MPCEs).
2. Close all monitored guards. If the Module is wired to single-channel input, the second input (S21/S23 or S11/S13) must be jumpered if unused.
3. Apply input power (only) to the Gate Monitor Module at terminals A1 and A2 (see ["Figure: Wiring to the guarded machine on page 6\).](#) The following LEDs should come ON: Power, Input 1, Input 2  
If the Power LED comes ON, but either or both Input LEDs are not ON, disconnect input power and check the wiring of the connected switch(es) and/or the jumper. Check if the jumper is installed correctly on the unused input. Return to step 2 after the cause of the problem has been corrected.
4. Step 4 varies, depending on how the module is configured.

Option	Description
If the Module is set to single-channel operation	After the Power, Input 1, and Input 2 LEDs all are ON, open and close all connected guards one at a time. When each individual guard opens, the corresponding Input LED must turn OFF, and when the guard closes its LED must come ON again.
If the Module is set to dual-channel operation	After the Power, Input 1, and Input 2 LEDs all are ON, open the guard; both switches must open within 3 seconds, and both Input LEDs must turn OFF. If the red Fault LED comes ON, simultaneity between the switches or within one switch (between its NO and NC contacts) was not met. Check all wiring and the switches.
If the Module is set to Auto Reset	(Y1/Y2 closed and DIP switches set to Auto Reset), the output LED will come ON as soon as both Input LEDs are ON (output contacts 13/14 and 23/24 close).
If the Module is set to Manual Monitored Reset	The Output LED should come ON only if Input 1 and 2 LEDs are ON and the Reset button connected to Y1 and Y2 went from open to closed and back to open position.

5. Repeat step 4 individually for each guard that is being monitored.
6. Close the guard. Apply power to the machine control elements and perform the ["Periodic Checks" on page 8.](#)

NOTE: Make sure that both Input 1 and 2 LEDs are ON only when ALL connected guards are closed. If the guards are closed and the Input LEDs are OFF, the guard switches may be wired incorrectly, which could reset the Module inappropriately (safety output contacts close as soon as one of the connected guards opens).

Do not continue operation until all checks are completed and all problems are corrected. See [Do Not Use Machine Until System is Working Properly](#) warning, and ["Repairs" on page 12](#) and ["Troubleshooting" on page 9](#) for further information.

### Periodic Checks

Banner Engineering highly recommends performing the periodic checks as described. However, a qualified person (or team) should evaluate these generic recommendations considering their specific application and determine the appropriate frequency of checkouts. This will generally be determined by a risk assessment, such as the one contained in ANSI B11.0. The result of the risk assessment will drive the frequency and content of the periodic checkout procedures and must be followed.

**WARNING:**

- **Do not use the system until the checkouts are verified**
- Attempts to use the guarded/controlled machine before these checks are verified could result in serious injury or death.
- If all these checks cannot be verified, do not attempt to use the safety system that includes the Banner Engineering Corp. device and the guarded/controlled machine until the defect or problem has been corrected.

A Designated Person is identified in writing by the employer as being appropriately trained to perform a specified checkout procedure. A Qualified Person possesses a recognized degree or certificate or has extensive knowledge, training, and experience to be able to solve problems relating to safety switch installation.

At each shift change or machine setup, a Designated Person should perform the following checks on all safety switches:



1. Verify the switch, sensor, actuator, or magnet are not broken or damaged.
2. Check for good alignment between the switch and actuator or sensor and magnet.
3. Confirm the switches are not being used as an end-of-travel stop.
4. Correct any loosened mounting hardware.
5. Verify it is not possible to reach any hazard point through an opened guard (or any opening) before hazardous machine motion stops completely.
6. Open and close each guard separately while verifying that the Gate Monitor outputs operate correctly throughout the check procedure. Follow each gate closure with a manual reset, if needed. If a contact set fails, the Safety Module will not enable its reset function. If the Safety Module does not reset, a switch may have failed; that switch must be immediately replaced.
7. In addition, a Qualified Person should perform the following on a periodic schedule (determined by the user, based upon the severity of the environment and the frequency of switch actuations):
  - a. Inspect the electrical wiring for continuity and damage.
  - b. Confirm that the wiring conforms to the instructions given in this installation manual.

Do not continue operation until all checks are completed and all problems are corrected. See ["Repairs" on page 12](#) and ["Troubleshooting" on page 8](#) for further information.

## Troubleshooting

Model GM-FA-10J Gate Monitoring Safety Module provides five LED indicators.

LED	Condition	Meaning
Power (green)	ON	Power is connected to terminals A1-A2.
	OFF	No power or low power to terminals A1-A2, or internal power supply failure.
Fault (red)	ON	External fault or configuration fault. The corresponding function LED will flash to indicate the area where the fault has been detected. See <a href="#">"Clearing Faults" on page 9</a> for probable cause.
	Flashing	Internal Fault. See <a href="#">"Repairs" on page 12</a> .
	Flashing (along with the Power LED flashing)	DIP Switch configuration fault. Check that switch positions are the same for both Banks A and B.
Input 1 (green)	ON	Guard 1 is closed and the inputs of Channel 1 are satisfied.
	OFF	Guard 1 is open or the inputs of Channel 1 are not satisfied.
	Flashing (along with the Fault LED ON)	See <a href="#">"Clearing Faults" on page 9</a> for probable cause.
Input 2 (green)	ON	Guard 2 is closed and the inputs of Channel 2 are satisfied.
	OFF	Guard 2 is open or the inputs of Channel 2 are not satisfied.
	Flashing (along with the Fault LED ON)	See <a href="#">"Clearing Faults" on page 9</a> for probable cause.
Output (green)	ON	Both internal relays K1 and K2 are energized (13/14 and 23/24 are closed).
	OFF	Both internal relays K1 and K2 are de-energized (13/14 and 23/24 are opened).
	Flashing	Reset requested. Cycle the Reset input (button) (open, closed, open) to enter RUN mode.
	Flashing (along with the Fault LED ON)	See <a href="#">"Clearing Faults" on page 9</a> for probable cause.

### Clearing Faults

To clear a fault condition, first correct the problem and then cycle the input channels to the module (open and close the guards). When the Fault LED lights, the corresponding Function LED will flash to indicate the problem. If the Fault LED is flashing, refer to ["Repairs" on page 12](#).

Input 1: S12/S13

Input 2: S22/S23

LEDs					Fault, Probably Cause, and Procedures
Power	Fault	Input 1	Input 2	Output	
On	On	Flashing	On or Off	Off	INPUT CHANNEL 1 FAULT (S11/S12/S13) a. S13 Open (guard closed) b. S12 Open (guard open) c. S11 Open (guard is open or closed) d. Short between S11 and S12
On	On	On or Off	Flashing	Off	INPUT CHANNEL 2 FAULT (S21/S22/S23) a. S23 Open (guard closed) b. S22 Open (guard open) c. S21 Open (guard is open or closed) d. Short between S21 and S22
On	On	Flashing	Flashing	Off	SHORT BETWEEN INPUT CHANNELS a. Short between S11 and S21
On	On	On or Off	On or Off	Off	SIMULTANEITY FAULT a. Dual-channel simultaneity > 3 seconds (configured for dual-channel operation) b. Channel simultaneity > 1 second (NO/NC did not switch within 1 second)  See <a href="#">"Configuration" on page 2</a> for description of complementary switching and dual-channel operation.
Flashing	Flashing	Off	Off	Off	DIP-SWITCH ERROR a. DIP-switch settings are incorrect; Bank A does not match Bank B  See <a href="#">"GM-FA-10J Configuration" on page 7</a> for DIP-switch configuration.
On	On	On	On	Flashing	OPEN RESET FAULT a. Y1/Y2 open when configured for Auto Reset  See <a href="#">"GM-FA-10J Configuration" on page 7</a> for Manual/Auto Reset information.

Continued on page 10

LEDs					Fault, Probably Cause, and Procedures
Power	Fault	Input 1	Input 2	Output	
On	Flashing	Off	Off	Off	INTERNAL FAULT (See "Repairs" on page 12) a. Incorrect check sum b. Internal relay failure (e.g., welded contact due to inductive load arcing.) c. Low input power d. Other internal fault

## GM-FA-10J Specifications

### Supply Voltage and Current

24 V DC ±15% at 150 mA (SELV-rated supply according to EN IEC 60950, NEC Class 2)  
 24 V AC ±15% at 150 mA, 50-60 Hz ±5% (NEC Class 2-rated transformer)  
 Power consumption: approx. 3 VA / 3 W  
 To comply with UL and CSA standards, the isolated secondary power supply circuit in the installation must incorporate a method to limit the overvoltage to 0.8 kV. The use of a 500 mA, slow blow fuse in series with the +24 V AC/DC is highly recommended. The GM-FA-10J does not contain an internal fuse.

### Supply Protection Circuitry

Protected against transient voltages and reverse polarity

### Overvoltage Category

Output relay contact voltage of 1 V to 150 V AC/DC: Category III  
 Output relay contact voltage of 151 V to 250 V AC/DC: Category II (Category III, if appropriate overvoltage reduction is provided, as described on [Overvoltage Cat II and III](#))

### Pollution Degree

2

### Status Indicators

One red LED: Fault (see "[Troubleshooting](#)" on page 8)  
 Four green LEDs: Power – power is supplied to Safety Module; Channel 1 – inputs satisfied (guard closed); Channel 2 – inputs satisfied (guard closed); Output – K1 and K2 energized, safety outputs closed

### Construction

Polycarbonate housing. Rated IEC IP20

### Mounting

Mounts to standard 35 mm DIN rail track. Safety Module must be installed inside an enclosure rated NEMA 3 (IEC IP54), or better.

### Mechanical life

≥ 50,000,000 operations

### Output Response Time

35 ms max.

Each normally open output channel is a series connection of contacts from two forced-guided (mechanically linked) relays, K1-K2.

### Output Configuration

Contacts: AgNi, 5 µm gold-plated  
 Low Current Rating: The 5 µm gold-plated contacts allow the switching of low current/low voltage. In these low-power applications, multiple contacts can also be switched in series (e.g., "dry switching").  
 To preserve the gold plating on the contacts, do not exceed the following max. values at any time:  
 Min. voltage: 1 V AC/DC; Max. voltage: 60 V  
 Min. current: 5 mA AC/DC; Max. current: 300 mA  
 Min. power: 5 mW (5 mA); Max. power: 7 W (7 VA)

### High Current Rating

If higher loads must be switched through one or more of the contacts, the minimum and maximum values of the contact(s) changes to:  
 UL Listed: Min voltage: 15 V AC/DC; Min current: 30 mA AC/DC; Min power: 0.45 W (0.45 VA); Max: 250 V AC / 24 V DC, 6 A resistive - B300, R300 per UL508  
 CE: Min voltage: 15 V AC/DC; Min current: 30 mA AC/DC; Min power: 0.45 W (0.45 VA); Max: 250 V AC / 24V DC, 6 A resistive - IEC 60947-5-1: AC15: 230 V ac, 3 A; DC-13: 24 V dc, 2 A

### Electrical life (switching cycles of the output contacts, resistive load)

150,000 cycles at 900 VA  
 1,000,000 cycles at 250 VA  
 2,000,000 cycles at 150 VA  
 5,000,000 cycles at 100 VA

### Simultaneity Monitoring

2-Channel operation: 3 seconds  
 1-Channel operation: infinite

### Input Requirements

Each switch or sensor must have a normally closed contact and a normally open contact capable of switching 20 to 50 mA at 15 to 30 V dc.  
 Reset switch: 20 mA at 12 V DC, hard contact only  
 Max. external resistance between terminals S11/S12, S11/S13, S21/S22 and S21/S23: 270 ohms each.

### Vibration Resistance

10 to 55 Hz at 0.35 mm displacement per IEC 60068-2-6

### Operating Conditions

0 °C to +50 °C (+32 °F to +122 °F)  
 90% at +50 °C maximum relative humidity (non-condensing)

### Safety Ratings

Category 4 PLe per EN ISO 13849-1; MTTFd = 100 years  
 SIL 3 per IEC 61508; PFHd = 1.54 × 10<sup>-9</sup>  
 SIL CL 3 per IEC 62061

### B10d Values

Voltage (V)	Current (A)	B10d
230 AC	2	100,000
230 AC	1	600,000
230 AC	0.5	1,300,000
24 DC	≤ 2 A	10,000,000

### Certifications



### Required Overcurrent Protection

**WARNING:** Electrical connections must be made by qualified personnel in accordance with local and national electrical codes and regulations.

Overcurrent protection is required to be provided by end product application per the supplied table.  
 Overcurrent protection may be provided with external fusing or via Current Limiting, Class 2 Power Supply.  
 Supply wiring leads < 24 AWG shall not be spliced.  
 For additional product support, go to [www.bannerengineering.com](http://www.bannerengineering.com).

Supply Wiring (AWG)	Required Overcurrent Protection (A)	Supply Wiring (AWG)	Required Overcurrent Protection (A)
20	5.0	26	1.0
22	3.0	28	0.8
24	1.0	30	0.5

**IMPORTANT:** Transient suppression is recommended when switching inductive loads. Install suppressors across load. Never install suppressors across output contacts (see Warning in [Overvoltage Cat II and III](#)).

GM-FA-10J Dimensions

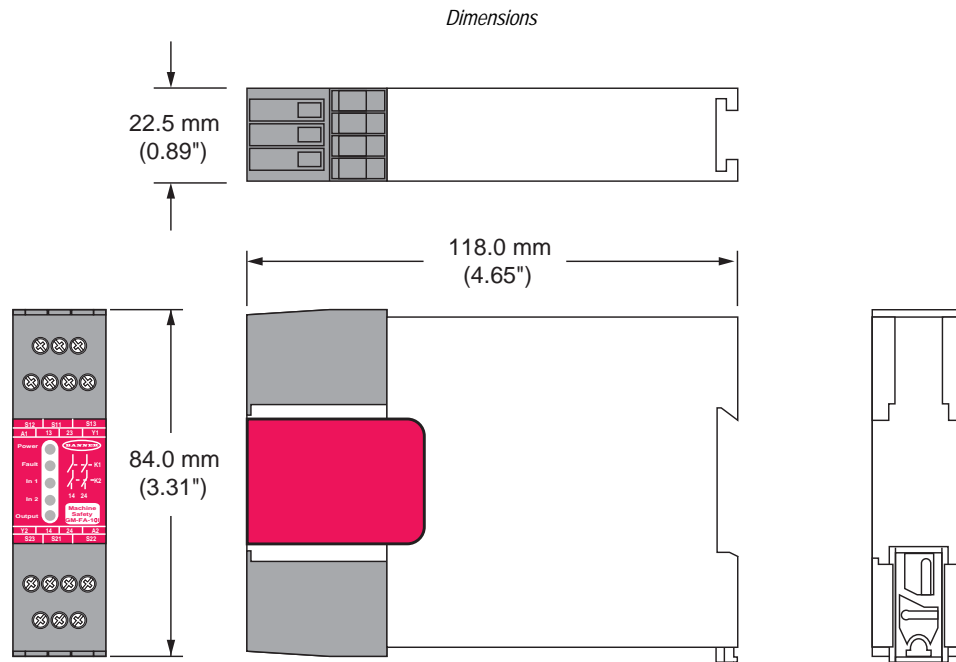

*Label*

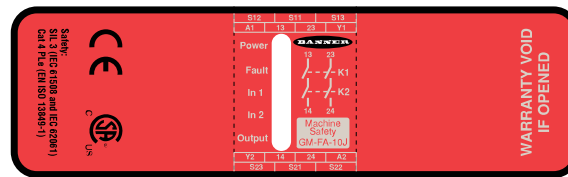

Related Products

SI-MAG Models

Magnet/Sensor Pair	Magnet Sensor		Coded Magnet
	Model	Connection	
	SI-MAGB1SM	3 m cable with flying leads	<b>SI-MAGB1MM</b> (Switching distance: 4 mm to 14 mm) OR <b>SI-MAGB1MM90</b> (90° orientation) (Switching distance: 4 mm to 14 mm) OR <b>SI-MAGB1MMHF</b> (Switching distance: 8 mm to 16 mm)
	SI-MAGB1SMCO	3 m cable with flying leads; cable opposite	
	SI-MAGB1SMQD	4-pin M8 QD connector	
	SI-MAGB1SMCOQD	4-pin M8 QD connector; connector opposite	
	SI-MAGB2SM	3 m cable with flying leads	<b>SI-MAGB2MM</b> (Switching distance: 3 mm to 14 mm)
	SI-MAGB2SMQD	4-pin M8 QD connector	
	SI-MAGB3SM	3 m cable with flying leads	<b>SI-MAGB3MM</b> (Switching distance: 5 mm to 14 mm)
	SI-MAGB3SMQD	4-pin M12 QD connector	

The magnet sensors listed have a 3 m (10 ft) cable. To order 9 m (30 ft) cables models, add **w/30** to the model number (e.g. **SI-MAGB1SM w/30**). (Older models without the **B**, are non-UL approved models. These older models do NOT work with **SI-MAGB** models.)

A basic SI-MAG system requires an SI-MAG sensor, coded magnet, cable (for QD versions), and a safety monitoring device.

**NOTE:** This manual also applies to the older magnetic switches, specifically the models that do not contain the 'B' in their model name.

## Product Support and Maintenance

### Repairs

Contact Banner Engineering for troubleshooting of this device. **Do not attempt any repairs to this Banner device; it contains no field-replaceable parts or components.** If the device, device part, or device component is determined to be defective by a Banner Applications Engineer, they will advise you of Banner's RMA (Return Merchandise Authorization) procedure.

Obtain assistance with product repairs by contacting your local Banner Engineering Corp distributor or by calling Banner directly at (763) 544-3164. Access literature translated into your native language on the Banner website at [www.bannerengineering.com](http://www.bannerengineering.com) or contact Banner directly at (763) 544-3164.

Para reparaciones de productos, por favor contacte a su distribuidor local de Banner Engineering o llame a Banner directamente al 00 1 (763) 544-3164. Ve la literatura traducida en su idioma en el sitio web Banner en [www.bannerengineering.com](http://www.bannerengineering.com) o comuníquese con Banner directamente al 00 1 (763) 544-3164.

Pour vous aider lors de la réparation de produits, contactez votre distributeur Banner local ou appelez directement Banner au (763) 544-3164. La documentation traduite dans votre langue est disponible sur le site internet de Banner [www.bannerengineering.com](http://www.bannerengineering.com) ou contactez directement Banner au (763) 544-3164.

请联系当地的 Banner Engineering Corp 经销商或直接致电 Banner +1 (763) 544-3164, 以获得产品维修帮助。请访问邦纳网站 [www.bannerengineering.com](http://www.bannerengineering.com) 或直接拨打 +1 (763) 544-3164 联系邦纳, 获取翻译成您母语的资料。

제품 수리에 대한 지원은 지역 Banner Engineering Corp 대리점에 문의하거나 Banner에 직접 (763) 544-3164로 문의하실 수 있습니다. 사용자의 모국어로 번역된 자료는 Banner 웹사이트 [www.bannerengineering.com](http://www.bannerengineering.com)에서 액세스하거나 Banner에 직접 (763) 544-3164로 문의하실 수 있습니다.

**IMPORTANT:** If instructed to return the device, pack it with care. Damage that occurs in return shipping is not covered by warranty.



**WARNING:**

- **Do not abuse the module after failure**—If an internal fault has occurred and the module will not reset, do not tap, strike, or otherwise attempt to correct the fault with a physical impact to the housing.
- Failure to follow these instructions could result in serious injury or death.
- An internal relay might have failed in such a manner that its replacement is required. If the module is not immediately replaced or repaired, multiple simultaneous failures might accumulate such that the safety function cannot be guaranteed.

### EU/UK Declaration of Conformity (DoC)

Banner Engineering Corp. herewith declares that these products are in conformity with the provisions of the listed directives and all essential health and safety requirements have been met. For the complete DoC, please go to [www.bannerengineering.com](http://www.bannerengineering.com).

Product	Directive
GM-FA-10J Gate Monitoring Safety Module	EU: 2006/42/EC
	UKCA: Machinery (Safety) Regulation 2008

Representative in EU: Spiros Lachandidis, Managing Director, **Banner Engineering BV** Park Lane | Culliganlaan 2F bus 3 | 1831 Diegem, BELGIUM

Representative in UK: Tony Coghlan, Managing Director, **Turck Banner LTD** Blenheim House | Blenheim Court | Wickford, Essex SS11 8YT | Great Britain

### Banner Engineering Corp Limited Warranty

Banner Engineering Corp. warrants its products to be free from defects in material and workmanship for one year following the date of shipment. Banner Engineering Corp. will repair or replace, free of charge, any product of its manufacture which, at the time it is returned to the factory, is found to have been defective during the warranty period. This warranty does not cover damage or liability for misuse, abuse, or the improper application or installation of the Banner product.

**THIS LIMITED WARRANTY IS EXCLUSIVE AND IN LIEU OF ALL OTHER WARRANTIES WHETHER EXPRESS OR IMPLIED (INCLUDING, WITHOUT LIMITATION, ANY WARRANTY OF MERCHANTABILITY OR FITNESS FOR A PARTICULAR PURPOSE), AND WHETHER ARISING UNDER COURSE OF PERFORMANCE, COURSE OF DEALING OR TRADE USAGE.**

This Warranty is exclusive and limited to repair or, at the discretion of Banner Engineering Corp., replacement. **IN NO EVENT SHALL BANNER ENGINEERING CORP. BE LIABLE TO BUYER OR ANY OTHER PERSON OR ENTITY FOR ANY EXTRA COSTS, EXPENSES, LOSSES, LOSS OF PROFITS, OR ANY INCIDENTAL, CONSEQUENTIAL OR SPECIAL DAMAGES RESULTING FROM ANY PRODUCT DEFECT OR FROM THE USE OR INABILITY TO USE THE PRODUCT, WHETHER ARISING IN CONTRACT OR WARRANTY, STATUTE, TORT, STRICT LIABILITY, NEGLIGENCE, OR OTHERWISE.**

Banner Engineering Corp. reserves the right to change, modify or improve the design of the product without assuming any obligations or liabilities relating to any product previously manufactured by Banner Engineering Corp. Any misuse, abuse, or improper application or installation of this product or use of the product for personal protection applications when the product is identified as not intended for such purposes will void the product warranty. Any modifications to this product without prior express approval by Banner Engineering Corp will void the product warranties. All specifications published in this document are subject to change: Banner reserves the right to modify product specifications or update documentation at any time. Specifications and product information in English supersede that which is provided in any other language. For the most recent version of any documentation, refer to: [www.bannerengineering.com](http://www.bannerengineering.com).

For patent information, see [www.bannerengineering.com/patents](http://www.bannerengineering.com/patents).