

U-GAGE® Q45UR Remote Ultrasonic Sensors

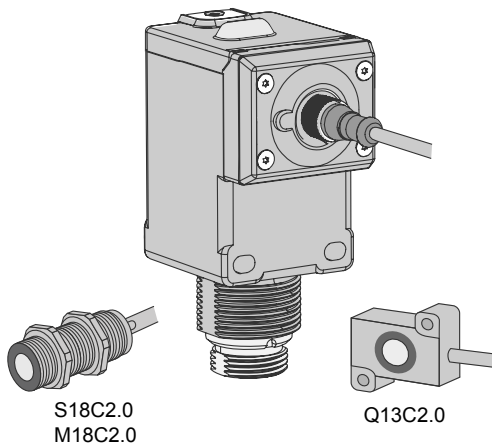

Datasheet

Piezoelectric Proximity Mode Sensors with Push-Button or Remote Programming of Sensing Windows



- Ultrasonic proximity detection from 50 mm to 250 mm (2 in to 10 in)
- Precision programmability that can resolve object presence to within 0.6 mm
- Window limits may be set in two ways: by individually setting the near and far window limits, or by programming a set point to be centered within one of four selectable window sizes
- Push-button TEACH-mode programming; input for remote programming
- Digital filtering for exceptional immunity to electrical and acoustic noise
- 12 DC to 24 V DC operation
- Bipolar outputs: one NPN and one PNP
- Wide operating temperature range of -25 °C to +70 °C (-13 °F to +158 °F); all models include temperature compensation
- User-selectable response speeds
- Easy-to-use in-window/out-of-window output; ideal for gauging and similar inspection applications
- Exceptional sensing repeatability: ±0.2% of the measured distance
- Choose from 3 remote sensors: 18 mm threaded-barrel models in either stainless steel or molded PBT polyester, and a molded flat-pack model
- Kit includes both a controller and a sensor; components are also sold separately
- Remote sensors connect to the controller via an integral 2 m (6.5 ft) cable



WARNING:

- **Do not use this device for personnel protection**
- Using this device for personnel protection could result in serious injury or death.
- This device does not include the self-checking redundant circuitry necessary to allow its use in personnel safety applications. A device failure or malfunction can cause either an energized (on) or de-energized (off) output condition.

Models

Kit Models	Kit Includes Controller Model	Controller Cable ¹	Kit Includes Sensor Model
Q45UR3BA63CK	Q45UR3BA63C	2 m (6.5 ft)	M18C2.0 Stainless Steel Barrel
Q45UR3BA63CQK	Q45UR3BA63CQ	Integral 5-Pin 7/8 in-16UNF male quick-disconnect connector	
Q45UR3BA63CQ6K	Q45UR3BA63CQ6	Integral 5-pin M12 male quick-disconnect connector	
Q45UR3BA63CKQ	Q45UR3BA63C	2 m (6.5 ft)	Q13C2.0 Flat-Pak
Q45UR3BA63CQKQ	Q45UR3BA63CQ	Integral 5-Pin 7/8 in-16UNF male quick-disconnect connector	
Q45UR3BA63CQ6KQ	Q45UR3BA63CQ6	Integral 5-pin M12 male quick-disconnect connector	
Q45UR3BA63CKS	Q45UR3BA63C	2 m (6.5 ft)	S18C2.0 Molded Barrel
Q45UR3BA63CQKS	Q45UR3BA63CQ	Integral 5-Pin 7/8 in-16UNF male quick-disconnect connector	
Q45UR3BA63CQ6KS	Q45UR3BA63CQ6	Integral 5-pin M12 male quick-disconnect connector	

Overview

The Q45UR ultrasonic sensor features a single button for programming the sensing window limits. You may set the window limits in one of two ways: programming two independent window limits, or defining a sensing distance set point, which is centered within a window whose size is determined by the setting of DIP switches 2 and 3.

Independent Window Limits. Place the target at the desired position to set the first limit. Set the second limit using the same procedure. To set two independent limits, the window must be at least 5 mm wide.

Sensing Distance Set Point. Teach the sensor the same set point for both window limits. This set point is centered within an overall window size of 1, 2, 3, or 4 mm (0.04, 0.08, 0.12, or 0.16 inches), determined by the DIP switch settings. The DIP switches are located inside the controller, under the inner cover.

¹ To order the 9 m (30 ft) cable models, add suffix **W/30** to the model number of any cabled sensor (for example, **Q45UR3BA63C W/30**). Models with a quick disconnect connector require a mating cable.



Figure 1. Q45UR Features

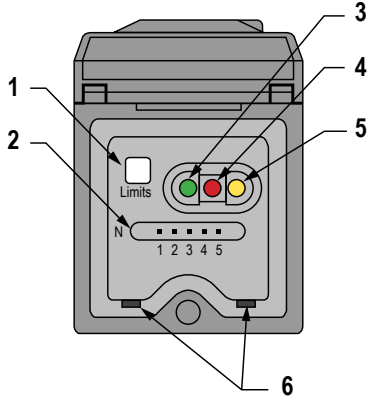

1. Button for programming the sensing window limits
2. 5-Segment target position indicator (N = Near)
3. Green power indicator
4. Red signal indicator
5. Amber output indicator
6. Slots for removing the inner cover

Status Indicators

Status indicator LEDs are visible through the transparent, o-ring sealed acrylic top cover. Their function is as follows:

- The green LED is solid when power is applied to the sensor and flashes to indicate an overloaded output.
- The red LED flashes when an echo is received. The flash rate is proportional to the echo strength.
- The amber LED is solid when the outputs are conducting.

The 5-segment moving dot LED indicator tracks the position of the target relative to the programmed window limits.

For Independent Window Limits (> 5 mm windows). LED 1 flashes when the target is closer than the near window limit. LED 5 flashes when the target is beyond the far window limit. LED 3 is on when the target is near the center of the two limits. When all the LEDs are off, there is no target present.

For Sensing Distance Set Points (1, 2, 3, or 4 mm windows). LED 1 flashes when the target is closer than the near window limit. LED 3 is on when the target is within the sensing window. LED 5 flashes when the target is beyond the far sensing window. When all the LEDs are off, there is no target present.

Configuring a Sensor

Setting the DIP Switches

Function	DIP Switches			
	1	2	3	4
Normally Closed Output Mode (output energizes when target is absent or outside the window limits)	ON			
Normally Open Output Mode (output energizes when target is sensed inside the window limits)	OFF *			
1 mm Window (Sensing set point ± 0.5 mm)		OFF	OFF	
2 mm Window (Sensing set point ± 1 mm)		ON	OFF	
3 mm Window (Sensing set point ± 1.5 mm)		OFF *	ON *	
4 mm Window (Sensing set point ± 2 mm)		ON	ON	
40 ms Response Time				ON
160 ms Response Time				OFF *

* Factory default settings

DIP switches 2 and 3 are used to set the window size if a set point is programmed. If two independent window limits are programmed, these switch settings are disregarded.



Note: Hysteresis is 0.5 mm for all window tolerance settings.

Figure 2. Q45UR DIP Switches (default settings)

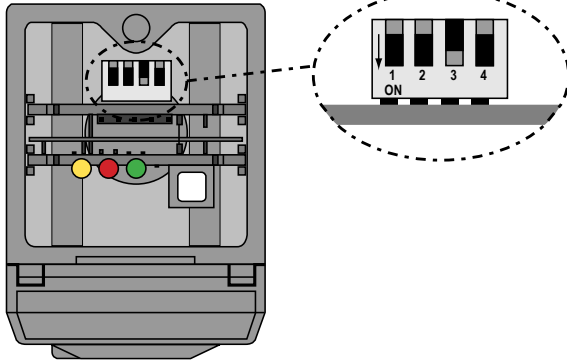
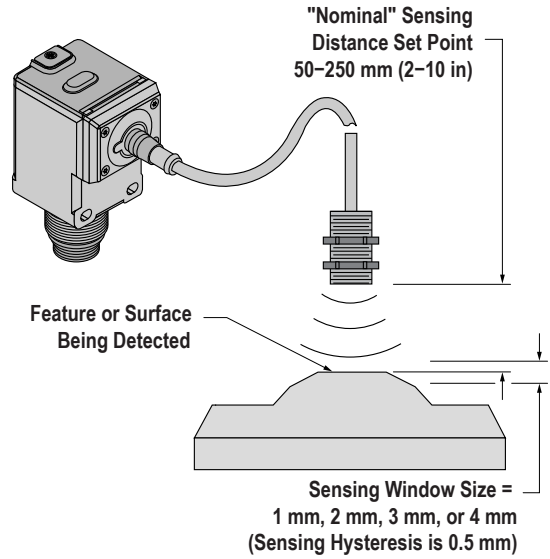

Figure 3. Sensing Distance Set Point and Window Size



To set the DIP switches:

1. Insert a small, flat-bladed screwdriver into the two slots shown in Figure 1 on page 2.
2. Remove the black inner cover to expose the DIP switches.
3. Set the required DIP switches.

Programming the Window Limits

Use the **Limits** button, located under the transparent top cover, to program the near and the far limits.

The near limit may be set as close as 50 mm (2 inches) and the far limit may be set as far as 250 mm (10 inches) from the transducer face. Minimum window width is 1 mm (0.04 inches). When possible, use the actual target to be sensed when setting the window limits.

The following procedure begins with the sensor in Run mode.

1. Access Programming Mode. Push and hold the **Limits** button until the green indicator LED turns off (approximately 2 seconds).

LED Indicator	Status
Green	Turns off
Amber	On to indicate the sensor is ready to learn the first limit
Red	Flashes to indicate the strength of the echo, or it is off if no target is present

2. Set the first limit (or single set point). Place the target at the first limit and press the **Limits** button for less than 2 seconds.

LED Indicator	Status
Green	Remains off
Amber	Flashes at 2 Hz to indicate the sensor is ready to learn the second limit
Red	On for a moment, then resumes flashing to indicate the strength of echo

3. Set the second limit. Place the target at the second limit and press the **Limits** button for less than 2 seconds.

LED Indicator	Status
Green	Remains off, then turns on (returns to Run mode)
Amber	On for a moment, then is either on or off to indicate the output state (returns to Run mode)
Red	On for a moment, then resumes flashing to indicate the strength of the echo (returns to Run mode)

Notes Regarding Window Limit Programming

1. Either the near or far limit may be programmed first.
2. There is a 2-minute time-out for programming the first limit. The sensor returns to Run mode with the previously programmed limits. There is no time-out between programming of the first and second limit.
3. Cancel the programming sequence at any time by pressing and holding the button for longer than 2 seconds. The sensor returns to Run mode with the previously programmed limits.
4. If a limit is rejected during either programming step, the sensor reverts to the first limit programming step, indicated by the Green LED (off), the Red LED (flashing to indicate signal strength), and the Amber LED (on).
5. If both limits are accepted, the sensor returns to Run mode, which is indicated by the Green LED (on).
6. During limit programming, the 5-segment moving dot indicator displays the relative target position between 50 mm (2 inches) and 250 mm (the maximum recommended far limit position is 250 mm (10 inches)).
7. If the target is farther than 250 mm (10 inches), the 5th segment of the moving dot indicator flashes to indicate that a valid echo is received, but the target is beyond the recommended 250 mm (10 inches) maximum far limit.
8. If the target is held at the same position for programming of both limits, the sensor establishes a 200 mm-wide sensing window, centered on the target position.

Remote Programming the Window Limits

Connect the yellow wire of the sensor to a switch or process controller for remote programming of the sensing window limits. The programming procedure is the same as for the button. A remote programming input is generated when +5 V DC to 24 V DC is applied to the yellow wire. The timing diagrams define the required input pulses.

H = +5 V DC to 24 V DC

L = Less than 2 V DC (or open circuit)

Notes regarding remote window limit programming:

1. The button is disabled during remote limit programming. (The remote programming input is disabled during push button programming.)
2. Also see the notes regarding window limit programming.

Figure 4. Remote programming the window limits

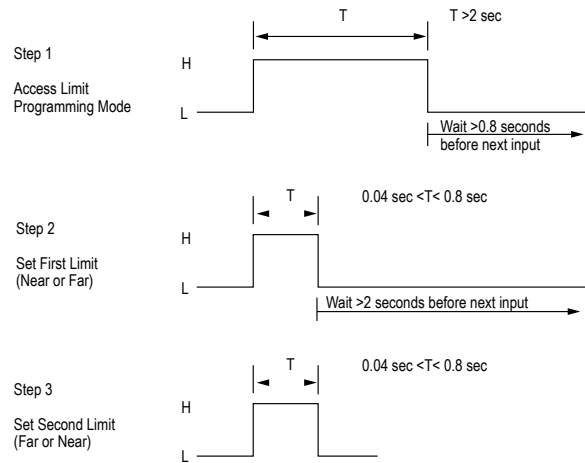

Wiring Diagrams

Q45UR Controller with Attached Cable	Q45UR Controller with 5-pin QD	Key
		<p>1 = Brown 2 = White 3 = Blue 4 = Black 5 = Gray (M12) or yellow (7/8 in-16UNF)</p> <p>Banner Engineering Corp. recommends that the shield wire be connected to earth ground or DC common.</p>

Specifications

Supply Voltage and Current

12 V DC to 24 V DC (10% maximum ripple) at 100 mA, exclusive of load

Sensing Distance Range

50 mm to 250 mm (2 in to 10 in)

Supply Protection Circuitry

Protected against reverse polarity and transient voltages

Output Configuration

Bipolar: one current PNP and one current NPN open collector transistor

Output Rating

150 mA maximum (each output)
OFF-state leakage current: < 25 microamps at 24 V DC
ON-state saturation voltage: < 1.5 V at 10 mA; < 2.0 V at 150 mA

Output Protection Circuitry

Protected against false pulse on power-up and continuous overload or short-circuit of outputs

Performance Specifications

Response speed: 40 or 160 milliseconds (switch selectable)
Repeatability²: ±0.2% of measured distance
Temperature stability: ±0.03% of the window limit positions per °C from 0 °C to 50 °C (±0.05% per °C over remainder of operating temperature range)
Sensing window width: 5 mm to 200 mm, when independent near and far limits are taught; 1, 2, 3, or 4 mm (switch selectable), when a sensing distance set point is taught
Hysteresis: 0.5 mm
Ultrasonic beam angle: ±3.5°

Connections

Controller: 2 m (6.5 ft) or 9 m (30 ft) attached cable, integral 5-pin 7/8 in-16UNF male quick-disconnect connector, or integral 5-pin M12 male quick-disconnect connector
Sensor: 2 m (6.5 ft) integral PVC-jacketed cable with a 4-pin M12 male quick-disconnect connector for connection to controller

Adjustments

4-position DIP switch

Indicators

Three status LEDs

Construction

Controller: Molded thermoplastic polyester housing, o-ring sealed transparent acrylic top cover, and stainless steel hardware
M18C2.0 Sensor: Stainless steel M18 threaded barrel housing and jam nuts, ULTEM® polyetherimide front cover, ceramic transducer, TEXIN® polyurethane rear cover
S18C2.0 Sensor: Thermoplastic polyester S18 threaded barrel housing and jam nuts, ULTEM® polyetherimide front cover, ceramic transducer, TEXIN® polyurethane rear cover
Q13C2.0 Sensor: Molded 30% glass reinforced thermoplastic polyester housing, ceramic transducer, fully epoxy-encapsulated
ULTEM® is a registered trademark of General Electric; TEXIN® is a registered trademark of Bayer Corporation

Environmental Rating

Controller: IP67; NEMA 6P
Sensor: IP65; NEMA 4

Operating Temperature

Controller and sensor: -25 °C to +70 °C (-13 °F to +158 °F)
85% at +50 °C maximum relative humidity (non-condensing)

Vibration and Mechanical Shock

All models meet MIL-STD-202F, Method 201A (Vibration: 10 Hz to 60 Hz maximum, 0.06 inch (1.52 mm) double amplitude, 10G maximum acceleration) requirements. Also meets IEC 60947-5-2 (Shock: 30G 11 ms duration, half sine wave) requirements.

Certifications



Banner Engineering
Europe Park Lane,
Culliganlaan 2F bus 3,
1831 Diegem, BELGIUM

Turck Banner LTD
Blenheim House,
Blenheim Court,
Wickford, Essex SS11
8YT, Great Britain

Application Notes

Use the Teach-mode function of the controller to set the sensing distance set point. Set the sensing window size using DIP switches 2 and 3. The sensing distance set point is centered within the sensing window. The size of the sensing window may be adjusted at any time, with or without power applied, and without re-teaching the sensing distance set point.

If the sensor is taught a window larger than 5 mm, the size of the window remains "fixed," disabling switches 2 and 3.

The controller has non-volatile memory which remembers the last sensing distance set point setting if power is removed and later reapplied.

The sensing distance set point may be programmed via the Remote Teach input (see wiring diagrams).

Minimum target size is a 10 × 10 mm aluminum plate (at any point within the 50 mm to 150 mm sensing range).

Acceptable target angle is within ±5° of normal for a smooth, flat target; target rotation does affect the apparent target location with respect to the sensor.

² Repeatability is specified using a 50 mm x 50 mm (2 in x 2 in) aluminum plate at 22 °C under fixed sensing conditions.

Performance Curves

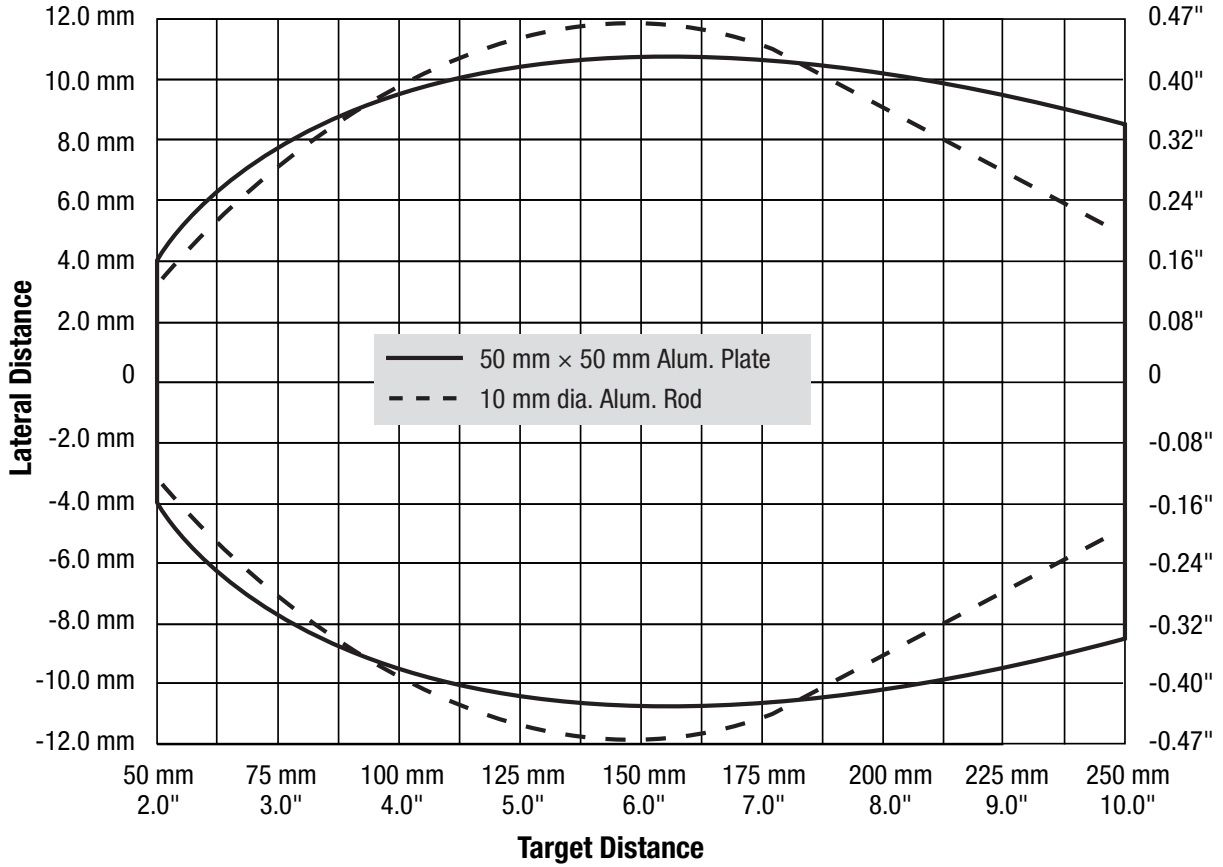

Note: The pattern displayed for the 50 mm x 50 mm aluminum plate is referenced to the edge of the plate. The pattern displayed for the 10 mm dia. aluminum rod is referenced to the center of the rod.

Dimensions

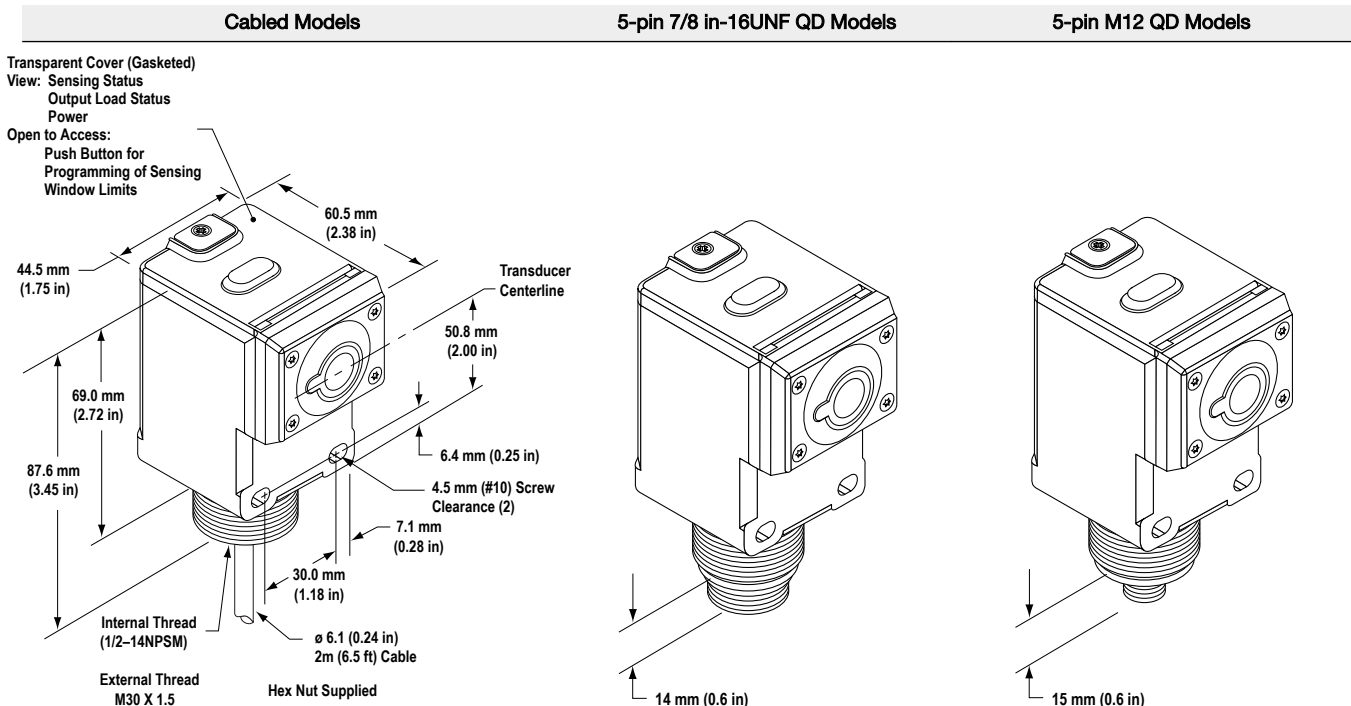

Dimensions for the Remote Sensors

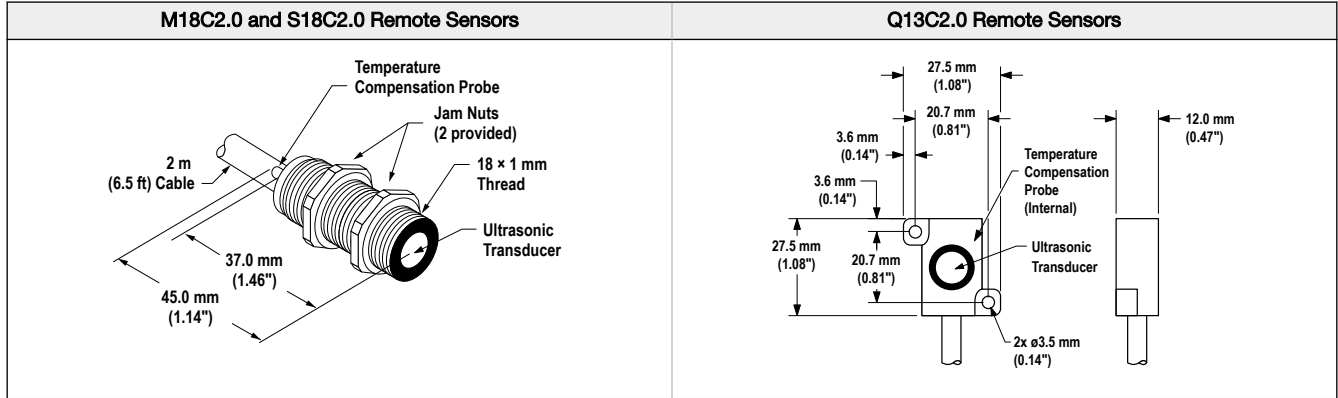

Accessories

Cordsets

5-Pin 7/8-In Cordsets with Shield—Single Ended				
Model	Length	Style	Dimensions	Pinout (Female)
MBCC2-506	2 m (6.56 ft)	Straight		<p>1 = Brown 2 = White 3 = Blue 4 = Black 5 = Yellow</p>
MBCC2-512	4 m (13.1 ft)			
MBCC2-530	9 m (29.5 ft)			

5-Pin Threaded M12 Cordsets with Shield—Single Ended				
Model	Length	Style	Dimensions	Pinout (Female)
MQDEC2-506	2 m (6.56 ft)	Straight		<p>1 = Brown 2 = White 3 = Blue 4 = Black 5 = Gray</p>
MQDEC2-515	5 m (16.4 ft)			
MQDEC2-530	9 m (29.5 ft)			
MQDEC2-550	15 m (49.2 ft)			
MQDEC2-575	23 m (75.44 ft)			
MQDEC2-5100	30.5 m (100 ft)	Right-Angle		<p>1 = Brown 2 = White 3 = Blue 4 = Black 5 = Gray</p>
MQDEC2-506RA	2 m (6.56 ft)			
MQDEC2-515RA	5 m (16.4 ft)			
MQDEC2-530RA	9 m (29.5 ft)			
MQDEC2-550RA	15 m (49.2 ft)			
MQDEC2-575RA	23 m (75.44 ft)			
MQDEC2-5100RA	31 m (101.68 ft)			

Brackets

SMB30S

- Swivel bracket with 30 mm mounting hole for sensor
- Adjustable captive swivel ball
- Black reinforced thermoplastic polyester
- Stainless steel mounting and swivel locking hardware included

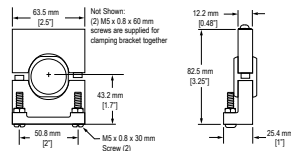

SMB30C

- 30 mm split clamp, black PBT bracket
- Stainless steel mounting hardware included
- Mounting hole for 30 mm sensor

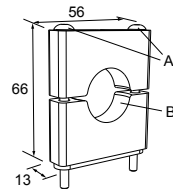

Hole center spacing: A=ø 45
Hole size: B=ø 27.2

SMB30MM

- 12-ga. stainless steel bracket with curved mounting slots for versatile orientation
- Clearance for M6 (¼ in) hardware
- Mounting hole for 30 mm sensor

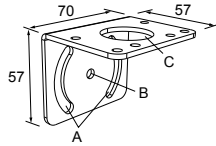

Hole center spacing: A = 51, A to B = 25.4
Hole size: A = 42.6 x 7, B = ϕ 6.4, C = ϕ 30.1

Brackets for M18C2.0 and S18C2.0 Sensors

SMB18A

- Right-angle mounting bracket with a curved slot for versatile orientation
- 12-ga. stainless steel
- 18 mm sensor mounting hole
- Clearance for M4 (#8) hardware

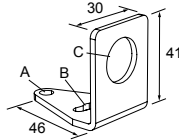

Hole center spacing: A to B = 24.2
Hole size: A = ϕ 4.6, B = 17.0 x 4.6, C = ϕ 18.5

SMB18C

- 18 mm split clamp, black thermoplastic polyester
- Stainless steel mounting hardware included

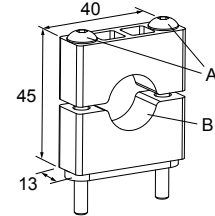

A = ϕ 3 mm (2)
Hole size: B = ϕ 18 mm

SMB18S

- 18 mm swivel bracket
- Black thermoplastic polyester
- Stainless steel mounting hardware included (Two M5 x 0.8 x 60 mm screws)

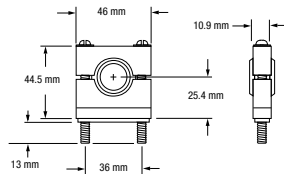

Banner Engineering Corp Limited Warranty

Banner Engineering Corp. warrants its products to be free from defects in material and workmanship for one year following the date of shipment. Banner Engineering Corp. will repair or replace, free of charge, any product of its manufacture which, at the time it is returned to the factory, is found to have been defective during the warranty period. This warranty does not cover damage or liability for misuse, abuse, or the improper application or installation of the Banner product.

THIS LIMITED WARRANTY IS EXCLUSIVE AND IN LIEU OF ALL OTHER WARRANTIES WHETHER EXPRESS OR IMPLIED (INCLUDING, WITHOUT LIMITATION, ANY WARRANTY OF MERCHANTABILITY OR FITNESS FOR A PARTICULAR PURPOSE), AND WHETHER ARISING UNDER COURSE OF PERFORMANCE, COURSE OF DEALING OR TRADE USAGE.

This Warranty is exclusive and limited to repair or, at the discretion of Banner Engineering Corp., replacement. **IN NO EVENT SHALL BANNER ENGINEERING CORP. BE LIABLE TO BUYER OR ANY OTHER PERSON OR ENTITY FOR ANY EXTRA COSTS, EXPENSES, LOSSES, LOSS OF PROFITS, OR ANY INCIDENTAL, CONSEQUENTIAL OR SPECIAL DAMAGES RESULTING FROM ANY PRODUCT DEFECT OR FROM THE USE OR INABILITY TO USE THE PRODUCT, WHETHER ARISING IN CONTRACT OR WARRANTY, STATUTE, TORT, STRICT LIABILITY, NEGLIGENCE, OR OTHERWISE.**

Banner Engineering Corp. reserves the right to change, modify or improve the design of the product without assuming any obligations or liabilities relating to any product previously manufactured by Banner Engineering Corp. Any misuse, abuse, or improper application or installation of this product or use of the product for personal protection applications when the product is identified as not intended for such purposes will void the product warranty. Any modifications to this product without prior express approval by Banner Engineering Corp will void the product warranties. All specifications published in this document are subject to change; Banner reserves the right to modify product specifications or update documentation at any time. Specifications and product information in English supersede that which is provided in any other language. For the most recent version of any documentation, refer to: www.bannerengineering.com.

For patent information, see www.bannerengineering.com/patents.