

To Be Performed at Every Power-up, Shift Change, and Machine Setup:

Daily checkout and checkouts after tooling and machine changes must be performed by a Designated Person (appointed and identified in writing by the employer). During continuous machine run periods, this checkout must be performed at intervals not to exceed 24 hours. A copy of checkout results should be kept on or near the machine: see OSHA 1910.217(e)(1).

The Designated Person (designated by the employer to perform this procedure) must:

- 1) Verify that access to the dangerous parts of the guarded machine is not possible from any direction not protected by the MINI-SCREEN System, hard guarding, or supplemental guarding, and verify that all supplemental guarding devices and hard guarding are in place and operating properly (see Figure 1).
- 2) Verify that the minimum separation distance from the closest hazard point of the guarded machine to the defined area is not less than the calculated distance (see Figure 1).

Calculated separation distance for this machine is _____.
To be entered by a Qualified Person, (as defined by ANSI B30.2-1983) at the time of installation. See manual, section 3.2.1 for more information.

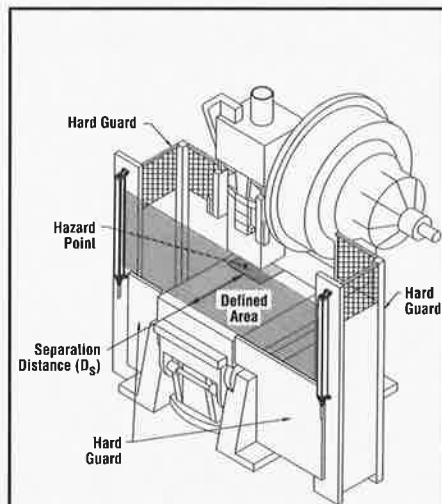

Separation Distance is calculated by a formula that takes into account:

- The stopping speed of the machine being guarded,
- The speed of the average human hand,
- The response time of the MINI-SCREEN System, and
- The spacing of the individual beams and whether floating blanking is ON.

Separation Distance is calculated to ensure that if a hand (or other body part) crosses the Defined Area (the area crossed by the beams), the machine will stop in time to prevent injury. (See manual, section 3.2.1 for more information.)

Figure 1. One example of hard guarding and separation distance



WARNING . . . Maintain Proper Separation Distance

Failure to maintain appropriate separation distance (as indicated above) can result in serious injury or death.

- 3) Ensure that it is not possible for a person to stand between any defined area and the dangerous parts of the guarded machine. Or, verify that supplemental presence-sensing devices (such as horizontal light screens) are in place and functioning properly in any space between the defined area and any danger point which is large enough to allow a person to stand undetected by the MINI-SCREEN System.



WARNING . . . Hard Guarding May be Required for Fixed Blanking

If any object that is to be ignored by fixed blanking does not, itself, completely prevent access to the hazard point(s), you must install hard guarding to prevent access past the object.

Openings in the hard guarding material must meet OSHA criteria (see OSHA 1910.217, Table O-10).

Failure to hard guard any opening caused by fixed blanking could lead to serious injury or death.

- 4) Verify that the enclosure for the MINI-SCREEN controller is latched and locked. The key (or combination or tool) to the locking mechanism should be in the possession of a Qualified Person (a person with the training or knowledge to solve problems relating to the system).



WARNING . . . Shock Hazard

A shock hazard exists while the lockable enclosure is open. Before continuing, verify that the enclosure is closed and latched. Failure to do so could cause serious injury or death.

MINI-SCREEN® Series – System Daily Checkout Procedure

- 5) Test the effectiveness of the MINI-SCREEN system with power ON, as described in steps (a) through (d), below. Use the chart below to select the proper test piece for your system configuration:

Floating Blanking Program	Standard 9 m (30') Range		Long-Range 18 m (60') Models	
	Specified Test Piece	Size (dia.)	Specified Test Piece	Size (dia.)
OFF	STP-2	19.1 mm (0.75")	STP-7	25.4 mm (1.00")
ON	STP-3	44.5 mm (1.75")	STP-8	50.8 mm (2.00")

- a) Verify that the MINI-SCREEN System is in RUN mode (green and yellow status indicators ON). (If the Auto Power-up feature is OFF when dc power is applied to the System, it is normal for it to power up into a Lockout condition. If this occurs, perform a Key Reset: Turn the key clockwise to RESET [yellow indicators go ON steadily]. Wait at least one-half second, then turn the key counterclockwise to RUN.) The green status indicator will flash if blanking is ON.
- b) *With the guarded machine at rest*, pass the appropriate Specified Test Piece downward through the defined area at three points: close to the receiver column, close to the emitter column, and midway between the emitter and receiver columns at right angles to the defined area (see Figure 2). In each case, the red status indicator should come ON and remain ON for as long as the test piece is within the defined area. When the test piece is withdrawn from the defined area, the green status indicator should come ON (if blanking is ON, the green status indicator will be flashing). (For Latching models: Perform a Key Reset to reset the latch after each pass of the test piece.) If the green indicator comes ON at any time when the test piece is within the defined area, check for reflective surfaces and unguarded areas created by use of fixed blanking (see Warning). Do not continue until the cause is discovered and the situation is resolved.
- c) Initiate machine motion of the guarded machine and, while it is moving, insert the appropriate Specified Test Piece into the defined area (at right angles to the defined area). **Do not attempt to insert the test piece into the dangerous parts of the machine.** (For Latching models: Perform a Key Reset to reset the latch after each pass of the test piece.) Upon insertion of the test piece into the defined area at any time during machine motion, the dangerous parts of the machine should come to a stop with no apparent delay. Upon removal of the test piece from the defined area, verify that the machine does **not** automatically restart, and that the initiation devices must be engaged to restart the machine.
- d) With the guarded machine at rest, insert the appropriate Specified Test Piece into the defined area and verify that it is not possible for the guarded machine to be put into motion while the specified test piece is within the defined area. (For Latching models: Perform a Key Reset to reset the latch after each pass of the test piece.)
- 6) Test the Emergency Stop switch (if one is connected to the MINI-SCREEN controller). With the machinery running, engage the Emergency Stop switch (to open its contacts). Verify that the dangerous machine motion stops with no apparent delay. Test each Emergency Stop switch individually, when two or more switches are series-connected to a MINI-SCREEN controller.
- NOTE: See WARNING regarding wiring of two or more Emergency Stop switches (Section 3.5 of manual).
- 7) Check carefully for external signs of damage to the MINI-SCREEN System, the guarded machine, and their electrical wiring. Any damage found should be reported immediately to management.
- 8) If all checks cannot be verified, shut machine down and do not use until the problem(s) has been corrected.

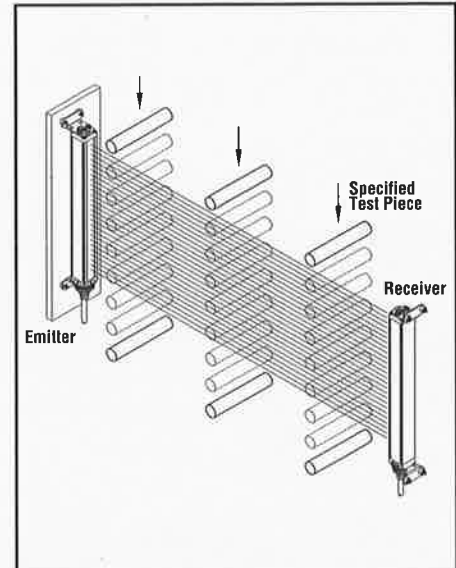

Figure 2. MINI-SCREEN System trip test



WARNING . . .

Reflective Surfaces

A highly reflective surface (a shiny workpiece or machine surface) may reflect sensing light around an object in the defined area, preventing that object from being detected. This potentially dangerous condition is discovered using the "trip test."

When this condition is discovered, eliminate the problem reflection(s):

- **Relocate the sensors** to move the light screen away from the reflective surface(s), being careful to retain the minimum separation distance (see Figure 1).
- **Otherwise, paint, mask, or roughen the interfering shiny surface** to reduce its reflectivity.
- **Use the trip test to verify that these changes have eliminated the problem reflection(s).** If the workpiece is especially reflective and comes close to the light screen, perform the trip test with the shiny workpiece in place.



WARNING . . . Do Not Use Machine If System Does Not Check Out

If *all* of these checks cannot be verified, do not use the MINI-SCREEN System/guarded machine until the defect or problem has been corrected (see Section 5 of the manual). **Doing so could result in serious bodily injury or death.**