

SM30 Series EZ-BEAM Opposed Mode Sensor Pairs

Leakproof 30-mm ac barrel sensors for demanding industrial applications



- Economical opposed mode sensor pairs in leakproof 30-mm threaded VALOX® barrels; quad-ring sealed acrylic lenses
- Ideal for high-humidity and high-pressure washdown applications such as laundries, car washes, and food processing
- 20 to 250 volt ac operation; 3-wire receiver hookup
- Receiver output is solid-state AC switch; 300 milliamps maximum, continuous; choice of light- or dark-operate models



These are economical opposed mode sensor pairs in leakproof (NEMA 6P rated) 30-mm threaded barrel VALOX® housings. Their size, shape, leakproof construction, mounting options, and price make them ideally suited for use in applications which undergo high-pressure washdown, such as car washes and food processing.

SM30 Series EZ-BEAM ac opposed mode pairs operate from 20 to 250V ac. The receiver's solid-state output is capable of switching up to a 300-milliamp continuous load. Receivers are available with either light-operate or dark-operate output configuration. See **Specifications section, below, for model listing.** Any receiver may be paired with any emitter. Emitters and receivers must be ordered separately.

Receivers have a red LED indicator that glows steadily whenever the receiver "sees" the modulated light from the emitter and flashes to indicate marginal excess gain (1-1.5x) in the light condition. The LED is internally mounted to maintain the integrity of the leakproof design, and is visible both through the front of the lens and through a sealed window on the side of the barrel near the lens.

SM30 Series EZ-BEAM ac opposed mode sensor pairs are available with either a 6-

1/2 foot attached PVC-covered cable or a 4-pin micro-type quick disconnect (QD) connector. Mating QD cable must be ordered separately (see *Specifications*, below).

Electronics are fully epoxy-encapsulated for maximum resistance to mechanical shock and vibration. Positive sealing at both ends of the sensor with no exposed epoxy interfaces eliminates all leakage paths (including capillary leakage). The acrylic lens is quad-ring sealed.

The 30-mm threaded barrel housings of SM30 Series EZ-BEAM sensors enable them to be mounted in 30-mm clearance holes. A wide selection of mounting brackets is available.

Specifications and Model Listings

Sensing range: 60 meters (200 feet).

Sensing beam: Infrared, 880 nanometers.

Supply voltage: 20 to 250V ac (50/60 Hz).

Supply current: Average current 20 mA.

Peak current 200 mA at 20V ac, 500 mA at 120V ac, 750 mA at 250V ac.

Model listing and output configurations:

Use either emitter: **SM303E** (6-1/2 foot attached cable) or **SM303EQ1** (micro-type QD fitting).

Receivers; solid-state ac output:

Model **SM30AW3R** = light-operate (6-1/2 foot attached cable)

Model **SM30AW3RQ1** = light-operate (micro-type QD fitting)

Model **SM30RW3R** = dark-operate (6-1/2 foot attached cable)

Model **SM30RW3RQ1** = dark-operate (micro-type QD fitting)

Light operate models: Output conducts when the receiver sees the emitter's modulated light source.

Dark operate models: Output conducts when sensing beam is blocked.

Output rating: 300 mA maximum (continuous).

Inrush capability 1 amp for 20 milliseconds, non-repetitive.

Off-state leakage current <50 microamps.

On-state voltage drop 3V at 300 mA ac; 2V at 15 mA ac.

Response time: 16 milliseconds "on"; 8 milliseconds "off"; independent of signal strength. No false pulse on power-up (false pulse protection circuit causes a 100 millisecond delay on power-up).

Repeatability 2 milliseconds; independent of signal strength.

Indicators:

Receivers have internally-mounted red LED that lights steadily whenever the receiver "sees" the emitter's modulated light source, and flashes to indicate marginal excess gain (1-1.5x) in the light condition. LED is visible both through the receiver's lens from the front and through a sealed window on the side of the barrel near the lens.

Emitters have internally-mounted red LED that lights steadily to indicate AC POWER ON. LED is visible both through the emitter's lens from the front and through a sealed window on the side of the barrel near the lens.

Construction:

M30x1.5 threaded VALOX® tubular housing with positive sealing at both ends. Completely sealed; epoxy-encapsulated circuitry. Quad-ring sealed acrylic lens. Exceeds NEMA 6P and IEC IP67 ratings. Two VALOX® jam nuts provided.

Cabling: 6-1/2 foot long (2 meter) attached PVC-covered 2-wire cable (emitters) and 3-wire cable (receivers), or 4-pin QD cable as follows:

MQAC-415 cable for models w/Q1 suffix; 12 feet long, straight micro-type QD connector

MQAC-415RA cable for models with Q1 suffix; 12 feet long, right-angled micro-type QD connector

Vibration and mechanical shock: meets Mil. Std. 202F requirements. Method 201A (Vibration: frequency 10 to 60 Hz, max., double amplitude 0.06-inch, maximum acceleration 10G). Method 213B conditions H & I (Shock: 75G with unit operating; 100G for non-operation).

Operating temperature range: -40° to +70°C (-40° to 158°F). Maximum relative humidity 90% at 50°C (non-condensing).



Hookup, SM30 Series EZ-BEAM ac opposed mode sensors (cabled models)

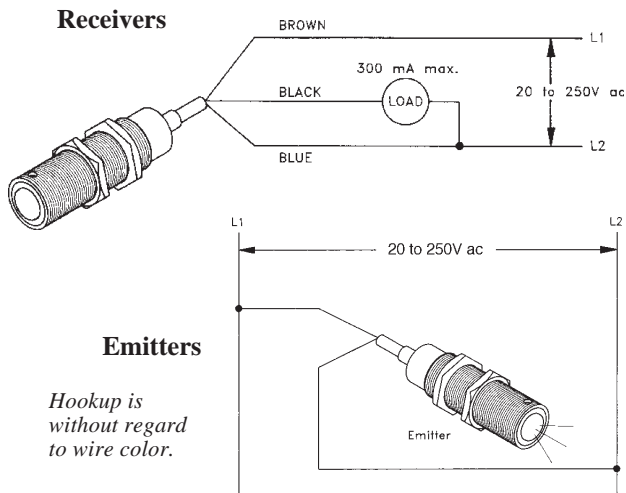

Sensors with **Q1** model suffix require **QD** (Quick Disconnect) cable. See Specifications section for information.

NOTE:

Receivers **SM30AW3R** and **SM30AW3RQ1** are light-operate. Output conducts when the receiver sees the emitter's modulated beam.

Receivers **SM30RW3R** and **SM30RW3RQ1** are dark-operate. Output conducts when the receiver does not see the emitter's modulated beam.

Any receiver may be paired with any emitter (**SM303E** or **SM303EQ1**).

Hookup information for **QD** sensors is provided with the sensor.

Excess Gain Curve

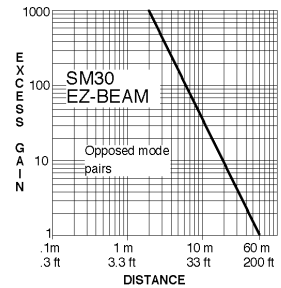

Beam Pattern

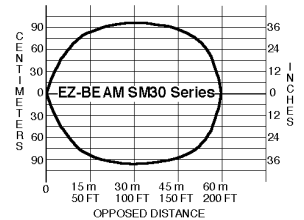

Dimensions, EZ-BEAM SM30 Series sensors

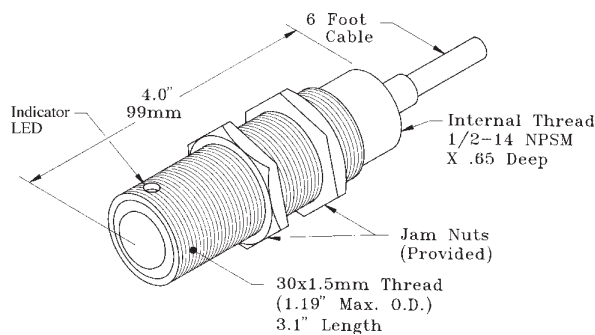

Quick Disconnect fitting adds .35" (9 mm) in overall length to QD models. QD models require Quick Disconnect cable (order separately; see Specifications section for information).

Mounting Options for EZ-BEAM S30 Series Sensors

The model **SMB30A** right-angled mounting bracket (not shown) has a curved mounting slot for versatility and orientation. The SM30 Series sensor mounts to the bracket using a jam nut (supplied with the sensor). The curved mounting slot has clearance for 1/4-inch screws. Bracket material is 11-gauge stainless steel.

The model **SMB30S** swivel-mount bracket (below, left) offers the ultimate in flexibility and convenience. This bracket mounts by its base. The SM30 threads into the adjustable captive "ball" of the bracket, which locks snugly in position when two clamping bolts are tightened. Bracket material is black VALOX®. Hardware is stainless steel, and mounting bolts are included.

The model **SMB30C** split clamp (not shown) mounts to a flat surface and grips the SM30 sensor by its threaded barrel. This bracket is similar to the SMB30S, but without the adjustable ball.

SM30 Series sensors may also be mounted in a 30-mm clearance hole, using the supplied jam nuts.

SMB30S Swivel Mounting Bracket

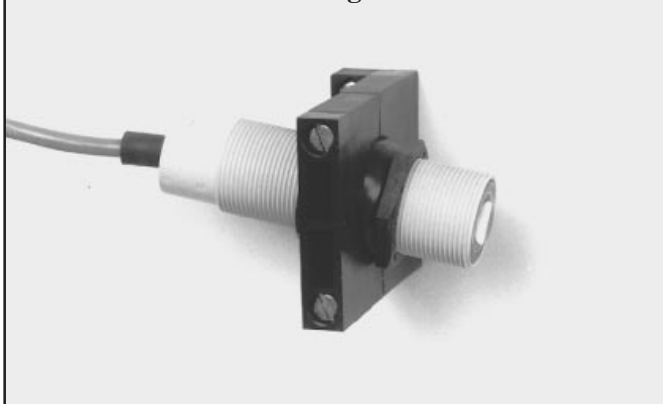

WARNING These photoelectric presence sensors do NOT include the self-checking redundant circuitry necessary to allow their use in personnel safety applications. A sensor failure or malfunction can result in *either* an energized or a de-energized sensor output condition.

Never use these products as sensing devices for personnel protection. Their use as safety devices may create an unsafe condition which could lead to serious injury or death.

Only MACHINE-GUARD and PERIMETER-GUARD Systems, and other systems so designated, are designed to meet OSHA and ANSI machine safety standards for point-of-operation guarding devices. No other Banner sensors or controls are designed to meet these standards, and they must NOT be used as sensing devices for personnel protection.

WARRANTY: Banner Engineering Corporation warrants its products to be free from defects for one year. Banner Engineering Corporation will repair or replace, free of charge, any product of its manufacture found to be defective at the time it is returned to the factory during the warranty period. This warranty does not cover damage or liability for the improper application of Banner products. This warranty is in lieu of any other warranty either expressed or implied.