



DXMR50-LB-2PA Programmable Logic Blocks

Original Instructions

p/n: 252380 Rev. B

02-Mar-26

© Banner Engineering Corp. All rights reserved. www.bannerengineering.com

Contents

Chapter 1 Overview	3
Models	3
Specifications	4
FCC Part 15 Class A for Unintentional Radiators	4
Industry Canada ICES-003(A)	4
Dimensions	5
Chapter 2 Configuration Instructions	6
Register Flow	6
DXMR50 Configuration Software Overview	7
Save and Upload the Configuration File	7
Starting Configuration	8
Data Stores	8
Action Rules	9
Threshold Rules	10
Register Copy Rules	11
Math and Logic Rules	11
Control Logic Rules	11
Trending and Filtering Rules	14
Tracker Rules	15
Decoder Rules	16
Delay and Scaler Rules	16
IO Configuration	16
Modbus Settings	16
Advanced Tab	17
Configuration Description	17
Read/Write Register Values	18
Reprogram	18
Chapter 3 Installation Instructions	20
Mechanical Installation	20
Chapter 4 Modbus Overview	21
DXMR50-LB-2PA Modbus Server IDs and Ports	21
Chapter 5 Accessories	23
Brackets	23
Cordsets	23
Chapter 6 Product Support and Maintenance	25
Repairs	25
Contact Us	25
Banner Engineering Corp Limited Warranty	25

Chapter Contents

Models 3
 Specifications 4

Chapter 1 Overview

Banner's DXMR50-LB-2PA Programmable Logic Block consolidates data from multiple sources to provide local data processing and logic functionality to solve applications independent of a higher-level control system.

The DXMR50-LB-2PA has two input ports, a programming port, and an output port. Data is collected into the internal logic controller to facilitate edge processing.

The programming port is a male M12 connection that also provides common power and ground to all M12 Modbus ports. Use the programming port and the BWA-UCT-900 adapter cable to connect to a PC to use the DXMR50 Configuration Software to configure the device.

DXMR50-LB input and output ports



Program the DXMR50-LB-2PA's logic controller using action rules and the DXMR50 Configuration Software.

- Thresholds (IF/THEN/ELSE) with timers, minimum on/off time
- Math/logic rules (arithmetic and bitwise operators)
- Control logic (logical operators and SR/T/D/JK flip-flops)
- Copy and decoding rules
- Trending (multiple averaging filters)
- Tracking (counts, on/off times)
- Delays (On Delay, Off Delay, On One-Shot, Off One-Shot, Pulse Stretch On, Pulse Stretch Off, Totalizer On, Totalizer Off)
- Scalers

Models

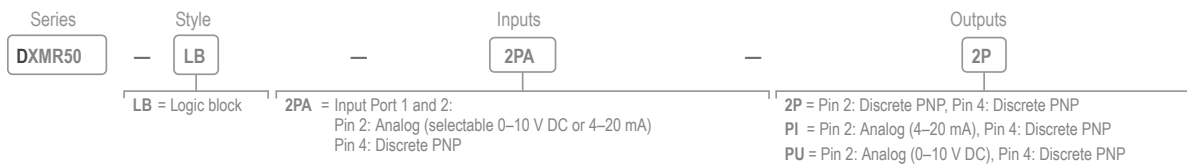

DXMR50-LB-2PA Ports

Port	2P Model	PI Model	PU Model
Port 0/Power	Pin 1 and 3: Power RTU server for configuration and register access		

Continued on page 4

Continued from page 3

Port	2P Model	PI Model	PU Model
Input Port 1	Pin 1 and 3: Power		
Input Port 2	Pin 2: Analog (selectable 0-10 V or 4-20 mA)		
	Pin 4: Discrete PNP		
Output Port	Pin 2: Discrete PNP	Pin 2: Analog (4-20 mA)	Pin 2: Analog (0-10 V)
	Pin 4: Discrete PNP	Pin 4: Discrete PNP	Pin 4: Discrete PNP

Specifications

Supply Voltage

12 V DC to 30 V DC

Power Consumption

400 mA maximum at 12 V DC

Supply Protection Circuitry

Protected against reverse polarity and transient voltages

Application Notes

Applying greater than 30 V on the IO pins may damage the unit

When connecting external devices through the DXMR50, it is important not to exceed the maximum current limitations of 4 Amps

Inputs

Sourcing discrete (PNP), 4–20 mA analog, 0–10 V analog

Accuracy $\pm 0.5\%$

Resolution: 10-bit

Analog Input Impedance

Current model: Approximately 250 ohms

Voltage model: Approximately 14.3K ohms

Analog Outputs (DAC)

4 to 20 mA or 0 to 10 V DC output Accuracy: 0.1% of full scale +0.01% per °C

Resolution: 12-bit

Discrete Input ON Condition

PNP: Greater than 7 V

Discrete Input OFF Condition

PNP: Less than 4 V

Discrete Output Load Rating

200 mA maximum current at 30 V DC

Construction

Connector Body: PVC translucent black

Indicators

Green: Modbus Communications

Amber: Discrete Input and Output Active Status

Green: Analog Input and Output Active Status

Connections

Three fixed nylon 5-pin M12 female quick disconnect connectors

One 5-pin nickel-plated brass M12 male quick disconnect

Communication Hardware (RS-485)

Interface: 2-wire half-duplex RS-485

Baud rates: 1.2K, 2.4K, 9.6k, 19.2k (default), 38.4k, 57.6K, or 115.2K

Data format: 8 data bits, no parity, 1 stop bit

Communication Protocol

Modbus® RTU

Environmental Ratings

For Indoor Use Only

IP65, IP67, NEMA 1, UL Type 1

Vibration and Mechanical Shock

Meets IEC 60068-2-6 requirements (Vibration: 10 Hz to 55 Hz, 1.0 mm amplitude, 5 minutes sweep, 30 minutes dwell)

Meets IEC 60068-2-27 requirements (Shock: 15G 11 ms duration, half sine wave)

Operating Conditions

–40 °C to +70 °C (–40 °F to +158 °F)

90% at +70 °C maximum relative humidity (non-condensing)

Storage Temperature

–40 °C to +80 °C (–40 °F to +176 °F)

Certifications



Banner Engineering BV
Park Lane, Culliganlaan 2F bus 3
1831 Diegem, BELGIUM



Turck Banner LTD Blenheim House
Blenheim Court
Wickford, Essex SS11 8YT
GREAT BRITAIN



FCC Part 15 Class A for Unintentional Radiators

This equipment has been tested and found to comply with the limits for a Class A digital device, pursuant to Part 15 of the FCC Rules. These limits are designed to provide reasonable protection against harmful interference when the equipment is operated in a commercial environment. This equipment generates, uses, and can radiate radio frequency energy and, if not installed and used in accordance with the instruction manual, may cause harmful interference to radio communications. Operation of this equipment in a residential area is likely to cause harmful interference in which case the user will be required to correct the interference at his own expense.

(Part 15.21) Any changes or modifications not expressly approved by the party responsible for compliance could void the user's authority to operate this equipment.

Industry Canada ICES-003(A)

This device complies with CAN ICES-3 (A)/NMB-3(A). Operation is subject to the following two conditions: 1) This device may not cause harmful interference; and 2) This device must accept any interference received, including interference that may cause undesired operation.

Cet appareil est conforme à la norme NMB-3(A). Le fonctionnement est soumis aux deux conditions suivantes : (1) ce dispositif ne peut pas occasionner d'interférences, et (2) il doit tolérer toute interférence, y compris celles susceptibles de provoquer un fonctionnement non souhaité du dispositif.

Dimensions

All measurements are listed in millimeters [inches], unless noted otherwise. The measurements provided are subject to change.

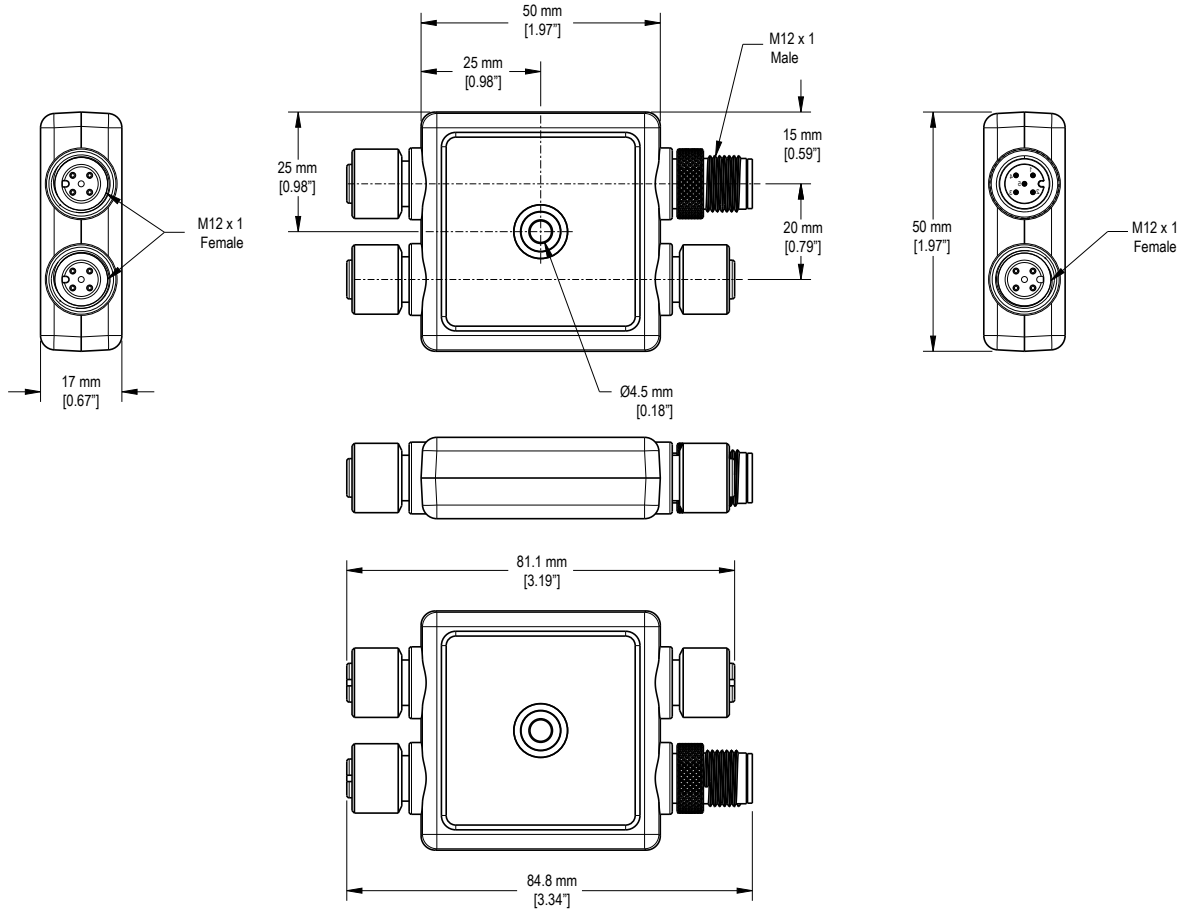

Chapter Contents

Register Flow 6
 DXMR50 Configuration Software Overview 7
 Save and Upload the Configuration File..... 7
 Starting Configuration 8
 Data Stores 8
 Action Rules 9
 IO Configuration 16
 Advanced Tab 17

Chapter 2 Configuration Instructions

Register Flow

The DXMR50-LB-2PA register data flows through the local registers, which are data storage elements within the processor. Use the DXMR50-LB Logic Block Configuration Software to program the controller to move register data from the data store registers to the I/O ports.

The DXMR50-LB-2PA moves and manipulates data using an on-board collection of uint32 registers referred to as data stores. Each DXMR50-LB-2PA model has 20 general-purpose data stores that can be used in tandem with action rules to transform data and achieve a wide range of logic operations.

Device-specific input and output data stores are also defined for each DXMR50-LB-2PA model; the logic established using action rules should accept data from the input data store(s) and ultimately place the results in the output data store(s).

Input/output data stores

Data Name	Constant Value	Counter Rate	Used in Read Rules	Used in Write Rules	Used in Action Rules	ID
PNP Discrete Out 1				Yes		2
PNP Discrete Out 2				Yes		4
PNP Discrete In 1			Yes			5
PNP Discrete In 2			Yes			6
Analog 4-20mA In 1			Yes			8
Analog 4-20mA In 2			Yes			11
Data Store 1						21
Data Store 2						22
Data Store 3						23
Data Store 4						24
Data Store 5						25
Data Store 6						26
Data Store 7						27
Data Store 8						28
Data Store 9						29
Data Store 10						30
Data Store 11						31
Data Store 12						32

Note: Users familiar with non-R50 DXM models may note that data stores behave much like the local registers configured on those devices. Data stores serve as an abstraction for these registers, enforcing standards regarding register quantity and use (input, output, or generic) for the DXMR50 device family.

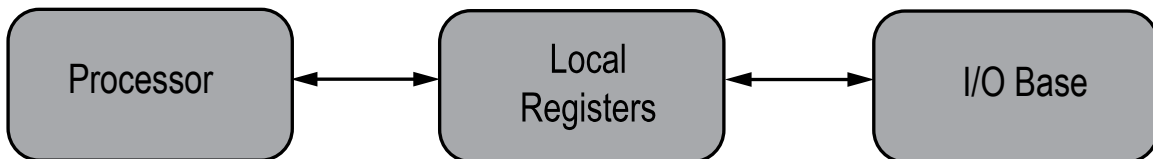

DXMR50 Configuration Software Overview

Use the DXMR50-LB Logic Block Configuration Software to customize your DXMR50-LB-2PA Programmable Logic Block configuration and process data from the controller.

Download the latest version of all configuration software from www.bannerengineering.com. For detailed instructions on how to program any DXMR50-LB Logic Block, download the configuration software manual, p/n [252379](#).

This configuration file defines parameters for the DXMR50-LB-2PA and saves the configuration in an XML file on the PC. After the configuration file is saved, connect the DXMR50-LB-2PA to your PC using adapter cordset **BWA-UCT-900** to upload the XML configuration file to the DXMR50-LB-2PA for operation.

Use the configuration software either while connected to a DXM or as a standalone configuration software.

To detect the DXMR50-LB-2PA that you have connected to your PC using the BWA-UCT-900 adaptor, select **Auto Detect** to load the **Starting Configuration** screen.

The top-level menus are similar to other Windows programs: **File**, **Traffic**, **DXM**, and **Help**.

- Use the **File** menu to manage the loading and saving of the XML configuration file created by the configuration software.
- Use the **Traffic** menu to view data traffic on the serial bus.
- Use the **DXM** menu to send and retrieve XML configuration files to or from a connected DXM.
- Use the **Help** menu to load the configuration software instruction manual in your default PDF viewer.

Opening screen



To create an XML file in offline mode (without a DXMR50-LB-2PA connected to the PC), select the **Offline Configuration** options for DXMR50-2P series (I/O Only), the DXMR50-2M series (Modbus RTU Only), or the DXMR50-MPA series (I/O and Modbus RTU)

Save and Upload the Configuration File

After making any changes to the configuration, you must save the configuration files to your computer, then upload it to the device.

Changes to the XML file are not automatically saved. Save your configuration file before exiting the software and before sending the XML file to the device to avoid losing data. If you select **DXM > Send XML Configuration to DXM** before saving the configuration file, the software will prompt you to choose between saving the file or continuing without saving the file.

1. Save the XML configuration file to your hard drive by going to the **File > Save As** menu.
2. Go to the **DXM > Send XML Configuration to DXM** menu.

Status indicator bar

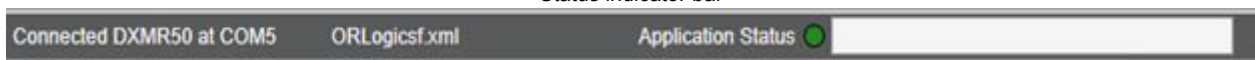

- If the Application Status indicator is red, close and restart the DXMR50-LB Logic Block Configuration Software, unplug and re-plug in the cable and reconnect the DXM to the software.
- If the Application Status indicator is green, the file upload is complete.
- If the Application Status indicator is gray and the green status bar is in motion, the file transfer is in progress.

After the file transfer is complete, the device reboots and begins running the new configuration.

Starting Configuration

Use the **Starting Configuration** screen to download the active configuration from the connected DXM or to start a new configuration.

Starting Configuration screen

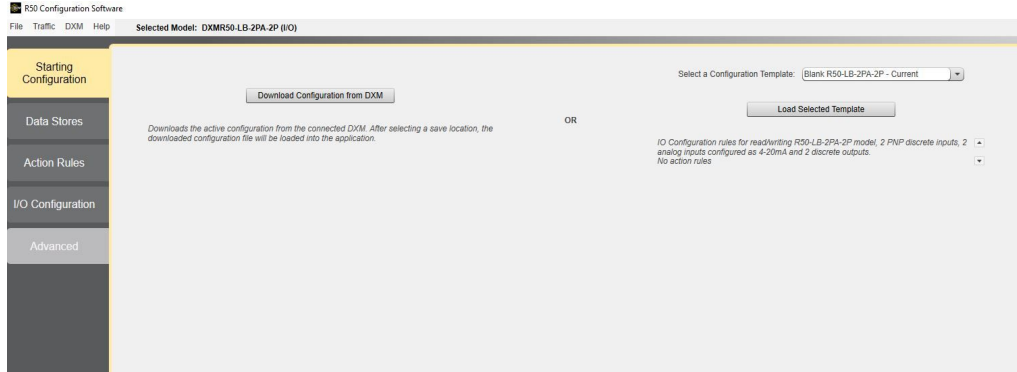

To start a new configuration, select a stock template from the drop-down list and select **Load Selected Template**. A description of the selected stock template is displayed below these controls. This option provides preloaded IO-Configuration rules to read/write the specific DXMR50 model you have selected and automatically assigns data store names.

Data Stores

Use the **Data Stores** screen to view a list of defined registers or to make changes to registers and show where the register is used in the defined configuration.

Data Stores screen

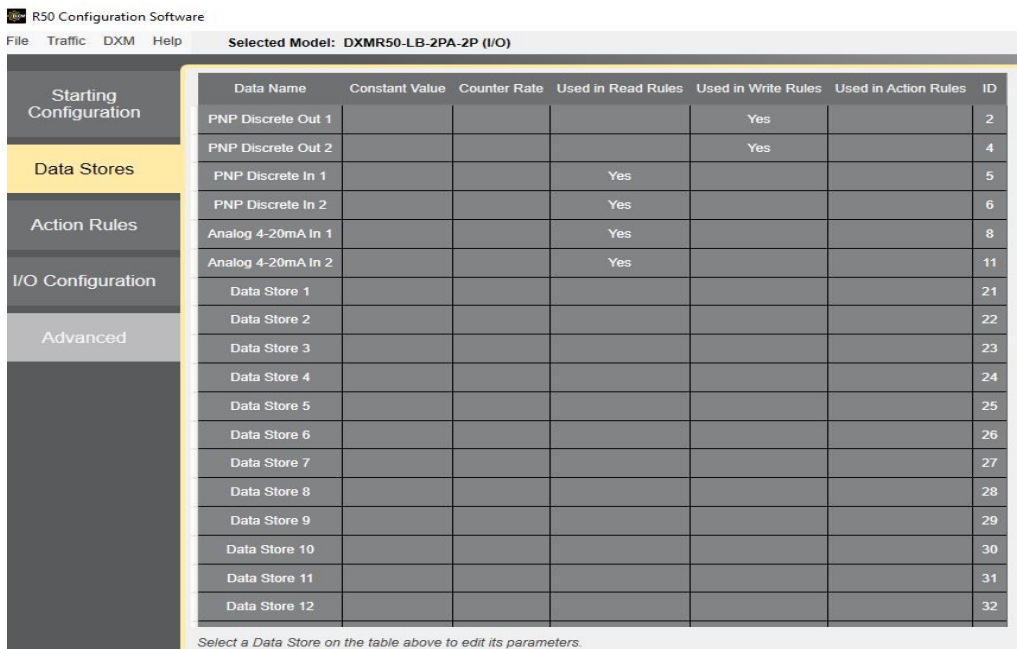

The **Edit Data Store** tab presents all the parameters for a single register. Select the register to modify using your keyboard's arrow keys or by clicking within the corresponding row in the Data Stores table. Use this section to assign the register a name, value type, or scaling. The value type and scaling options are drop-down lists.

Edit Data Store tab

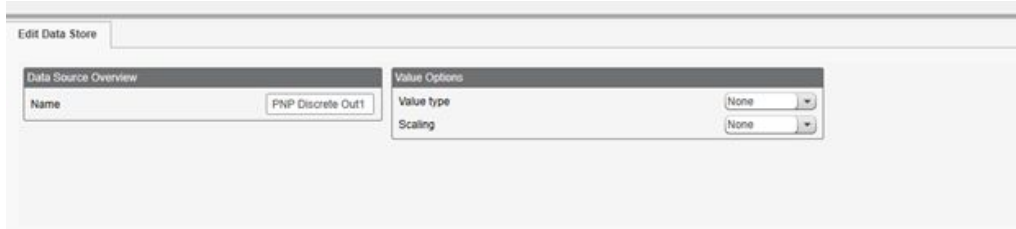

Value

None. The register has a value of 0 by default and can be modified by any source that has permission to set register values.

Constant. Forces the register to be set to the specified value. Used to compare values when using action rules. Constant values cannot be overwritten by any source that would normally have permissions to modify register values.

Counter. The value increments with the specified frequency (every 100 ms or every 1 second). Write to the data store registers to start the timer at a specific value.

Scaling

The scaling parameter changes the viewing of register data.

Scaling first applies a scale (add, subtract, multiple, divide, or modulo (remainder in division)), then adds an offset value. Select **Apply offset before scale value** to add the offset first and then apply the scale.

Action Rules

Action rules perform simple logic functions and manipulation of data store register data.

Action rule processing is autonomous from other data store functions.

Action Rules screen



- **Control Logic** rules are binary rules, with the results being either 0 or 1
- **Decoder** rules copy a subset of the bits in one register to a specified bit index within another register
- **Delay** rules allow for time-based logic between source and destination registers
- **Math/Logic** rules deal with 32-bit register logic with results from 0 to 4,294,967,295
- **Register Copy** rules copy the contents of one register to another
- **Scaler** rules transform the domain of register values between source and destination registers
- **Threshold** rules create event-driven conditions
- **Tracker** rules monitor a register value and store the result of a function in another register
- **Trending** rules find average, minimum, and maximum values

Each action rule is processed in order, similar to the read/write rules. The groups of action rules are solved in the following order:

1. Calculate (Math), continually processed
2. Copy rules, processed only when a change of state is detected on the source register
3. Threshold rules, continually processed
4. Control Logic, continually processed
5. Trending, continually processed
6. Trackers, continually processed.

All Action Rules also have **Clone Selected Rule** or **Delete Selected Rule** commands to quickly copy/paste or delete the selected rule.

Threshold Rules

A threshold rule triggers event messages to be sent to the cloud (event-driven push), pushes events to be stored to the local event log, and creates a standard push message to send all defined registers to the cloud.

A threshold rule creates a simple IF-THEN-ELSE comparison for a register to determine its value and set another register to indicate if the rule is true or false. Note that you must select a true option to set a false option. The definition section of the threshold rule sets the comparison and values. The definitions of the threshold rules can also be defined by the optional parameters, Hysteresis, On Time, and Logging options.

If selected, the false option (else condition) is applied. This creates an IF-THEN-ELSE structure. To remove the ELSE condition, deselect the false option or set the result register to itself.

Threshold Rules

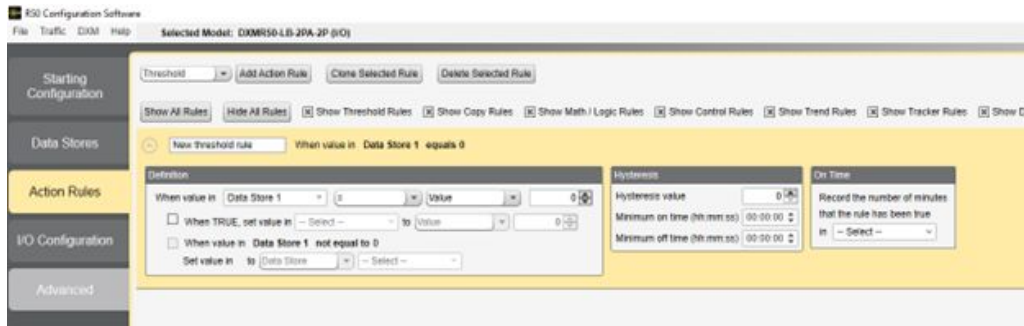

1. Write the threshold rule as a sentence.
2. Select the data store register, operator, and value from the drop-down lists.
3. Define the value of the register when the statement is true and when it is false.

Value/Register

When **Value** is selected, provide a fixed number in the following entry box.

When **Register** is selected, provide a data store register address in the following entry box.

The contents of the data store register are used in the threshold rule. When **Same as Source** is selected (else statement), the contents of the register defined in the **If** comparison is used as the result.

Hysteresis

Hysteresis is an optional parameter that is enabled only when values are non-zero. How hysteresis is applied depends on the comparison.

For a test that becomes true **if greater than**, the test will not return to false until the register is less than the test value by a margin of at least this hysteresis value.

If a test becomes true **if less than**, the test will not return to false until the register is greater than the test value by a margin of at least this hysteresis value.

Minimum On Time and **Minimum Off Time** are time-based parameters that govern how long a statement must be true or false to activate the output register.

On Time

Selecting **On Time** stores in a register how long (in minutes) the threshold rule has been true.

The **On-Time** value is shown in the data store register in minutes but maintains the internal counter in seconds. This results in the accuracy of seconds, not rounding of the value stored in the register.

Register Copy Rules

Use the Register Copy screen to copy one data store register into another data store register.

Register Copy screen

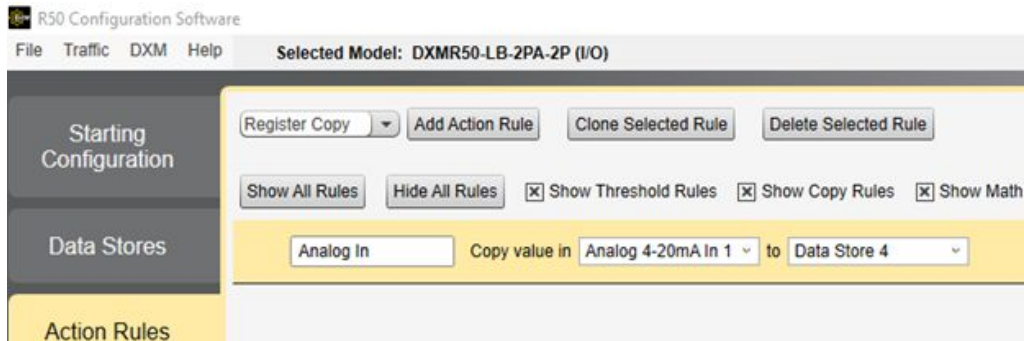

Math and Logic Rules

Math and logic rules deal with 32-bit register logic. In contrast, control logic rules are binary rules, with the results being either 0 or 1.

Math and Logic Rules screen

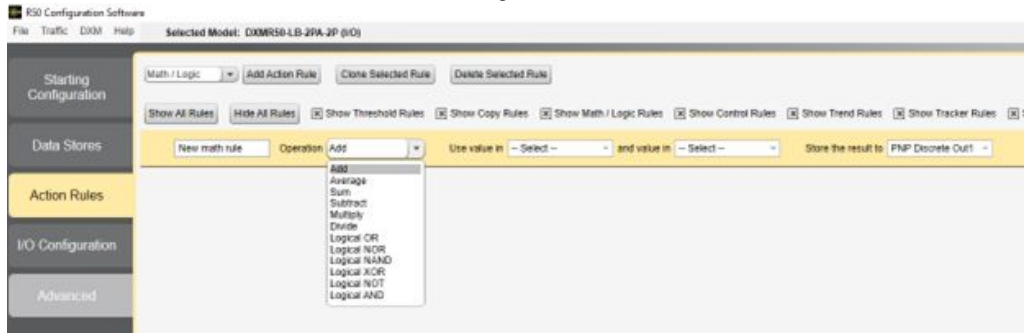

The average, sum, and logic operations are valid for ranges of registers. The data store registers are unsigned 32-bit integers. All math and logic functions can operate on all 32-bits.

The data store register operations are:

- Add. Adds two data store registers and stores the result in a data store register.
- Average. Averages the values of multiple registers and stores the result.
- Divide. Divides data register 1 by data store register 2 and stores the result. Dividing by zero results in a zero.
- Logic NOT. Performs a bit-wise one's complement on a register and stores the result.
- Logic OR, AND, NOR, NAND, XOR. Performs bit-wise logic functions on multiple registers and stores the result. Bit-wise logic functions operate on all 32-bits of the registers. To perform a logic function on a simple 0 or 1 in the registers, use the control logic rules.
- Multiply. Multiplies one register by another and stores the result.
- Sum. Adds multiple registers and stores the result in a data store register.
- Subtract. Subtracts register 2 from register 1 and stores the result. For negative numbers, the results are in two's complement form.

Control Logic Rules

Control logic rules are binary rules, with the results either 0 or 1.

Some control logic rules create memory elements using the data store registers as inputs and outputs. A value of zero in a register is defined as 0 in the control logic rule, and a non-zero value in a register is defined as a 1 value. Control logic rules are evaluated when an input value changes state.

Memory elements include J-K Flip/Flop, S/R Flip/Flop, D Flip/Flop, and T Flip/ Flop.

Control Logic Rules screen

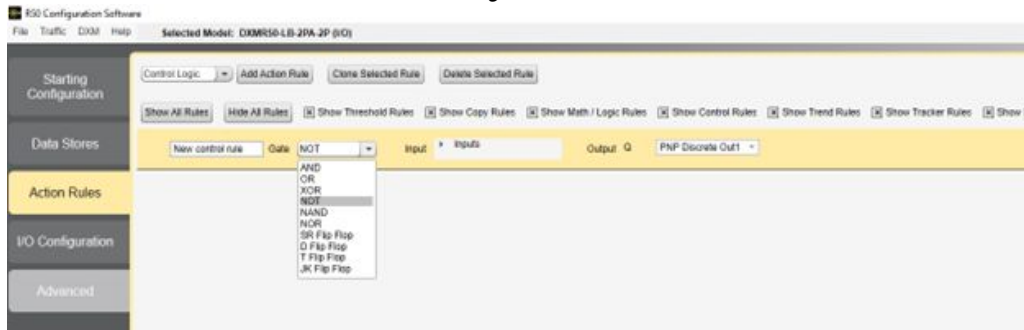

Control Logic

Control Logic				
Function	In 1	In 2	Q out	
AND	0	0	0	
	1	0	0	
	0	1	0	
	1	1	1	
OR	0	0	0	
	1	0	1	
	0	1	1	
	1	1	1	
XOR	0	0	0	
	1	0	1	
	0	1	1	
	1	1	0	
NOT	0	-	1	
	1	-	0	
NAND	0	0	1	
	1	0	1	
	0	1	1	
	1	1	0	
NOR	0	0	1	
	1	0	0	
	0	1	0	
	1	1	0	

NOTE: * Output Qn is an inverted output from the Q output and represents optional inputs or outputs. Leave the optional inputs or outputs connected to 0 when not used.

J-K Flip/Flop

If J and K are different, the output Q takes the value of J. The **Enable**, **Clock**, and **Qn** connections are not required for operation.

J-K Flip/Flop

*Enable	J	K	* Clock	Q	Qn *
0	X	X	X	No change	No change
1	X	X	0 or 1 or ↓	No change	No change
1	0	0	↑	No change	No change
1	1	0	↑	1	0
1	0	1	↑	0	1
1	1	1	↑	No change	No change

If an input is zero it is false (0), and if a value is non-zero (anything but zero) it is considered true (1). All but one requires two inputs; the NOT rule only has one input. Some of the control logic rules provide basic non-memory logic functions: AND, OR, XOR, NOT, NAND and NOR. These basic logic functions are based on zero and non-zero values and result in a 0 or 1.

Optionally, the rules can have a **Clock** input and an **Enable** input. The **Clock** input determines the time (0-1 rising edge) the rule is evaluated. The **Enable** input enables or disables the logic function.

- AND—Output is high (1) only if both inputs are non-zero
- OR—Output is high (1) if either input is non-zero
- XOR—Output is high (1) if either, but not both, inputs are non-zero
- NOT—Input is inverted to the output
- NAND—Output is low (0) if both inputs are high (> 0)
- NOR—Output is high (1) if both inputs are zero (0)

Set/Reset (S/R) Flip/Flop

The Set/Reset Flip/Flop, or S/R Latch, is the most basic memory device. The S input sets the output to 1, and the R input sets the output to 0. Selecting **Insert input** turns the inputs to low active, so a 0 on the S input set the Q output to 1. The truth table below is defined without the invert flag.

Set/Reset (S/R) Flip/Flop

S	R	Q	Qn *
1	0	1	0
0	0	No change	No change
0	1	0	1
1	1	Invalid ⁽¹⁾	

Delay (D) Flip/Flop

The Delay (D) Flip/Flop takes the D input to the outputs at the next rising edge of the clock. All other states of clock have no effect on the outputs. The **Enable** input is optional. A **Clock** input and a **D** input changing at the same time results in an undetermined state.

Invert Inputs—Typically a input value of "1" will be evaluated as true (active), selecting "Invert inputs" will result in a "0" value to be considered true(active).

Flip/Flop is R dominated—xxx

Table references:

- X = doesn't matter what the value is.
- <up arrow>, <down arrow> = signify a rising or falling edge of the clock input.
- * = optional input or output

⁽¹⁾ The Set input and Reset input active at the same time is an illegal condition and should not be used.

Delay (D) Flip/Flop

*Enable	D	Clock	Q	Qn *
0	X	X	No change	No change
1	X	0 or 1 or ↓	No change	No change
1	0	↑	0	1
1	1	↑	1	0

Toggle (T) Flip/Flop

The Toggle (T) Flip/Flop toggles the state of the output if the input is 1. The **Enable** input is optional. A **Clock** input and a **T** input changing at the same time results in an undetermined state.

Toggle (T) Flip/Flop

*Enable	T	Clock	Q	Qn *
0	X	X	No change	No change
1	X	0 or 1 or ↓	No change	No change
1	0	↑	0	1
1	1	↑	(toggle)	(toggle)

Trending and Filtering Rules

Use **Trending** rules to find the average, minimum, and maximum values for a specific register at a user-specified time interval. The Trend function collects data when the device boots up and accumulates the average, minimum, and maximum values for a register.

Local registers locations are defined include: Register to Track, Filter Register, Average Value Register, Minimum Value Register, Maximum Value Register, and Enable Register. When not using the local register definitions, leave them set to zero.

The filter and tracking is applied according to this flowchart.

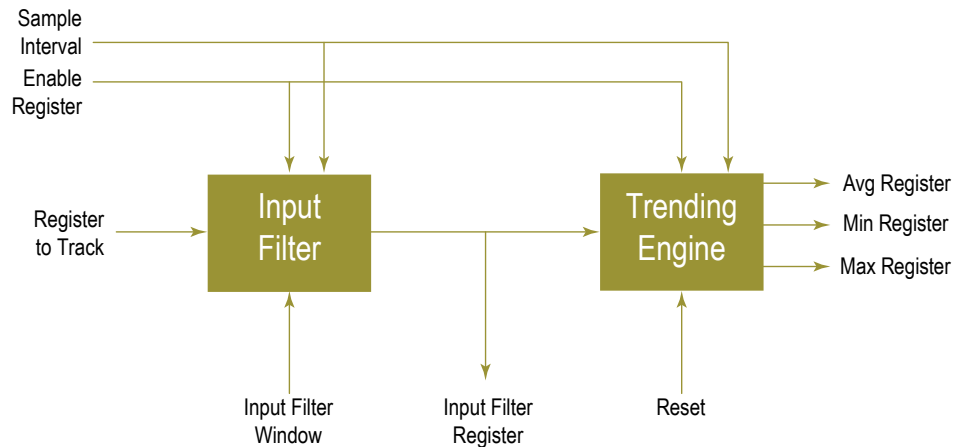

The trending rule has an optional filter input, and the filter output is the input to the trending operation. The filter result is used before applying the trending rule when you define the **Filter** parameter. The other trending parameters are listed. The Average, Minimum, and Maximum register fields are optional and can be left set to zero when using the Filter output register.

Register to Track

Local register to provide the input to the filter and trending rule.

Sample Interval

Defines the time interval of the samples to collect from the register.

Filter

Defines the specific filter algorithm to apply to the front end of the trending rule.

Cumulative Average. Sums the samples and divides them by the number of samples.

Exponential Moving Average. A moving average filter that applies weighting factors that decrease exponentially. The weighting for each older sample decreases exponentially, never reaching zero.

Lulu Smoother. Takes the minimum and maximum values of mini sequences of sample points. The mini-sequence length is defined by the filter window parameter.

Median Average. Takes a least three sample points, sorts the sample points numerically, and selects the middle value as the result. A new sample point entered into the filter removes the oldest sample point.

Recursive Filter. Created from a percentage of the current sample plus a percentage of past samples. The number of samples is determined by the **Filter Window** parameter.

Simple Moving Average. Takes the number of samples defined by the **Filter Window** parameter and averages the samples for the result. When a new sample is taken, it becomes the latest sample point, and the oldest sample point is taken out of the filter averaging.

Weighted Moving Average. A moving average filter that applies a weighting factor to the data based on when the data was captured. More recent data has a higher weighted factor.

Filter Window

Defines the number of samples for a filter algorithm. For example, if the sample interval is 5 minutes and the Filter Window is 100, this creates a 100-point moving average over a 500-minute time period.

Filter Register

The local register that stores the output of the first-stage filter. This is not required to connect the filter front-end to the trending rule processing.

Average Value Register

The local register number to store the average value of the trending rule. The average is calculated from the beginning of the power-up or from the **Reset Trending** time. (Hourly, Daily) Defining this local register is optional and can be left at zero.

Minimum Value Register

The local register number to store the minimum value of the trending rule. The minimum is captured from the beginning of power-up or from the **Reset Trending** time. (Hourly, Daily) Defining this local register is optional and can be left at zero.

Maximum Value Register

The local register number to store the maximum value of the trending rule. The maximum is captured from the beginning of power-up or from the **Reset Trending** time. (Hourly, Daily) Defining this local register is optional and can be left at zero.

Reset Trend Data

Use to reset the trend data accumulation. (Hourly, Daily, or not at all)

Enable Register

The **Enable Register** is an optional register and can be left set to zero. The **Enable Register** defines the address of a local register that can be used to turn on and off the trending function. Set the register value to 1 to turn on trending or to zero to turn off trending. When disabled, the current data is held until the rule is enabled again.

Tracker Rules

Tracker rules monitor a data store register and store the result of a function in another register.

Tracker Rules screen

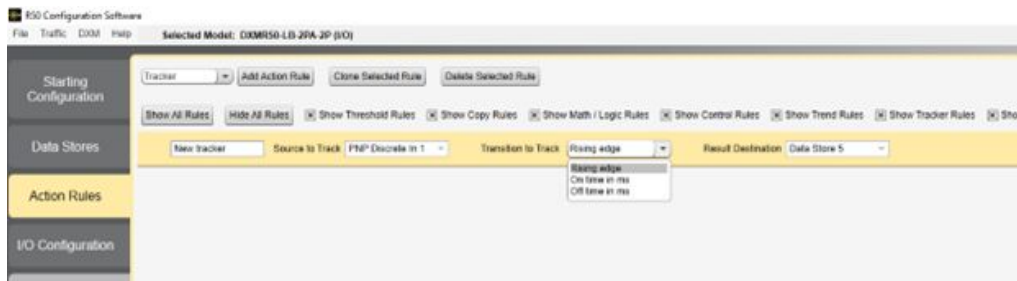

The possible functions are:

- **Rising Edge.** Counts the number of register transitions from 0 to non-zero value. The speed at which it can count depends on how much work the DXM is performing. Typical tracker rates should be around one to two times per second.
- **On time in ms.** Tracks the time (ms) that the register is in the non-zero state
- **Off time in ms.** Tracks the time (ms) that the register is in the zero state

Decoder Rules

Use the Decoders screen to copy a subset of the bits contained in a data store register location into another register.

Decoder Rules screen



Add Decoder Rule

Click to create a new decoder rule.

Name

Name your rule.

Copy from Source Register

The register to copy data from.

Number of bits

The total number of bits (minimum of 1, maximum of 32) to copy from the source register.

The **Number of bits** field auto-decrements when either of the **Starting at bit index** fields is increased to ensure that the number of bits copied does not overflow the maximum bit index of 31.

Starting at bit index

The specified number of bits will be copied from the source register ascending from the specified index (minimum of 0, maximum of 31). Starting at bit 0 will capture the lowest-order portion of the register's value, while starting at index 31 will copy only the highest-order bit.

Destination Register

The register to copy data to.

Starting at bit index

The lowest-order bit of the data copied from the source register will occupy this bit index in the destination register.

On the DXMR50-LB-2PA, these rules are executed by performing a bit shift, applying a mask, and writing the result to the destination register.

Delay and Scaler Rules

Delay rules allow for time-based logic between source and destination registers.

Scaler rules transform the domain of register values between source and destination registers.

IO Configuration

Go to the IO Configuration tab to define read rules, write rules, and the Modbus settings.

Both the Read Rules and Write Rules screens include a **Show Internal Rules** checkbox. These internal rules load with your starting configuration files and are default rules specific to the discrete/analog inputs and outputs. When the checkbox is not selected, the rules are hidden from view. For normal operation, the internal rules do not need to be changed.

Modbus Settings

Use the **I/O Configuration > Modbus Settings** screen to view and configure the DXMR50 server settings. Select the **Get** and **Set** buttons to view and adjust these settings.

Baud Rate

Defined for both the Modbus client and server
Settings include: 19200 (default), 1200, 2400, 9600, 38400, 57600, and 115200

Parity

Defined for both the Modbus client and server
Settings include: None (default), odd, even, space, and mark

Internal Server ID

The internal server ID is the Modbus ID that an external Modbus client accesses to read/write to the local registers on the DXMR50

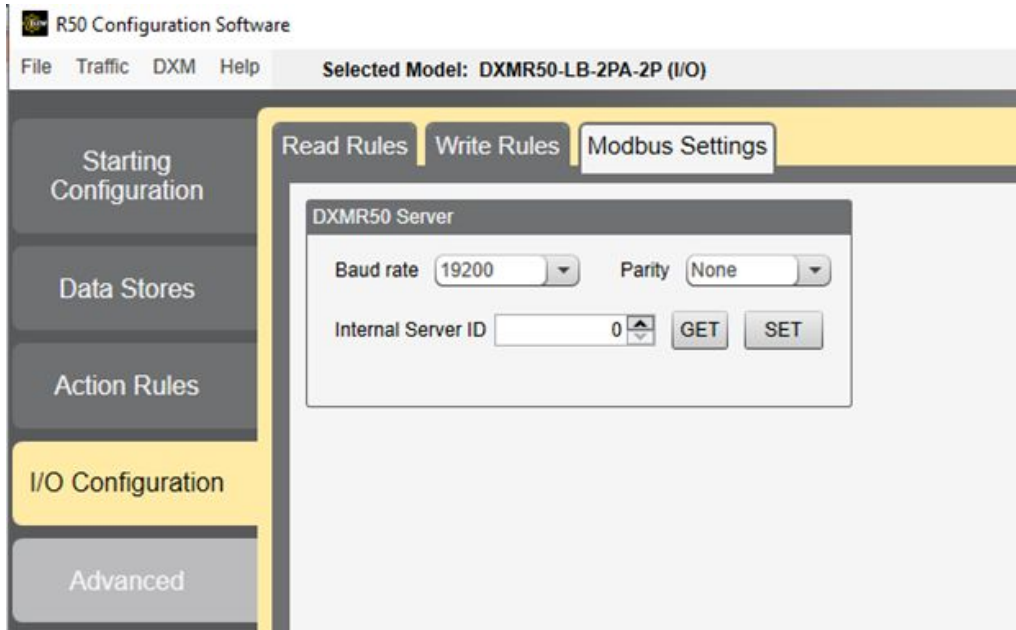

Advanced Tab

Access the Configuration Description, Read/Writer Register Values, and Reprogram screens from the Advanced tab.

Configuration Description

Use the **Configuration Description** screen to set and save the **Configuration Title** and **Configuration Details**.

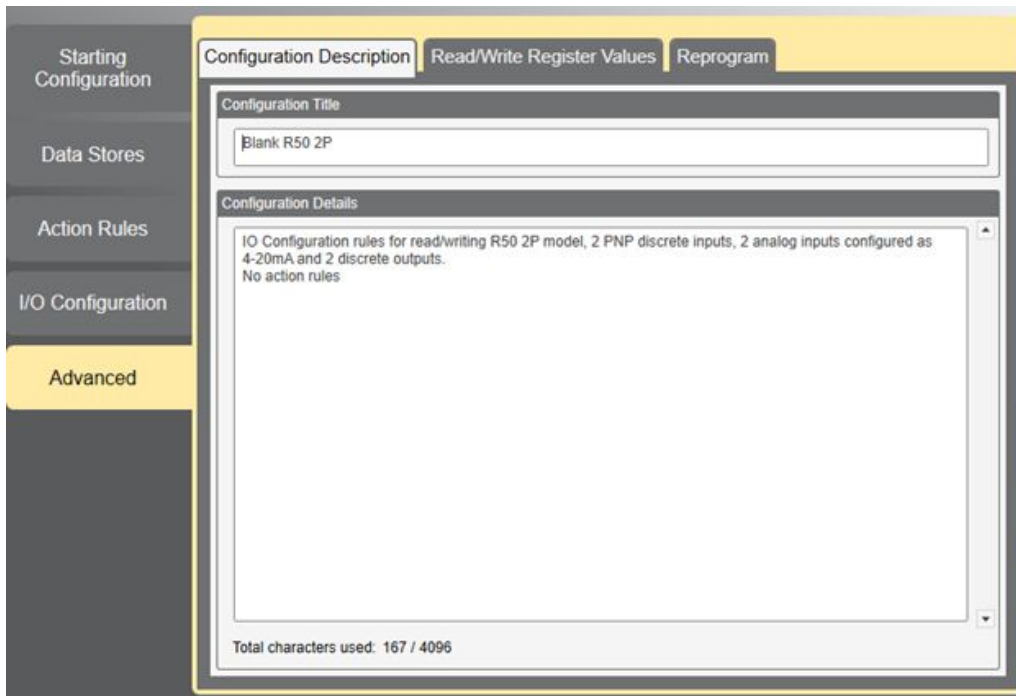

Read/Write Register Values

The Register View screen is a Modbus utility to help debug configurations and view register data for devices connected to the DXMR50.

Follow these steps to select the registers to view:

1. Connect to the DXMR50-LB-2PA using the BWA-UCT-900 adaptor.
2. From the **Register source** drop-down list, select between Remote Device, Data Stores, or DXM inputs/outputs.
3. Enter a Modbus ID when accessing remote devices.
4. Select the **Starting Register** to display.
5. Select the number of registers to display.

To read the contents of a specific register or range of registers:

1. Select the starting register.
2. Select the number of registers to read from.
3. Click **Read Registers** to read the data once. The register values display in the **Read Registers** section.
4. Select **Enable Polling**.
5. Specify a polling rate.
6. Click **Read Registers** to create a constant polling loop.

To write values to a specific register or range of registers:

1. Select the starting register.
2. Select the number of registers to write to.
3. Enter the value to write to these registers.
4. Click **Write Registers** to send these defined values to the selected registers.

Reprogram

Use the Reprogram screen to update the DXM's firmware.

Click **Get Device Information** to have the DXM read and display its serial number, model number, version, and firmware numbers.

To reprogram the DXM, follow these instructions:

1. Connect the DXM to your PC using the BWA-UCT-900 adaptor cordset.
2. Go to the **Advanced > Reprogram** screen.
3. Click **Select upgrade file**.
4. Browse to the firmware HEX file location and select the file.

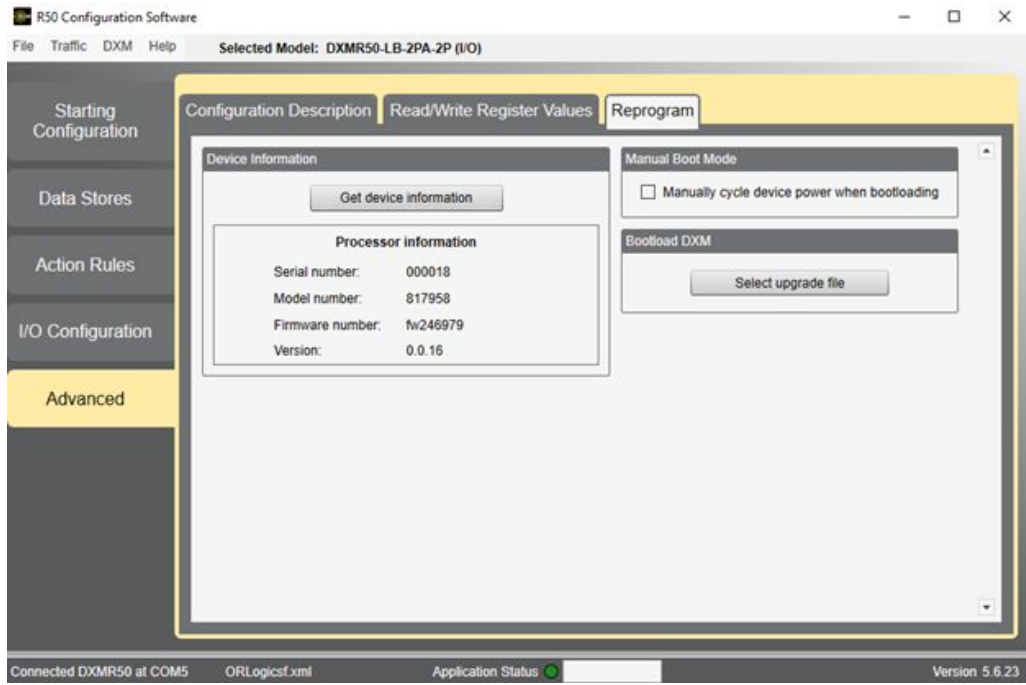

Chapter 3 Installation Instructions

Mechanical Installation

Install the DXMR50-LB-2PA to allow access for functional checks, maintenance, and service or replacement. Do not install the DXMR50-LB-2PA in such a way to allow for intentional defeat.

Fasteners must be of sufficient strength to guard against breakage. The use of permanent fasteners or locking hardware is recommended to prevent the loosening or displacement of the device. The mounting hole (4.5 mm) in the DXMR50-LB-2PA accepts M4 (#8) hardware.

See the figure below to help in determining the minimum screw length.

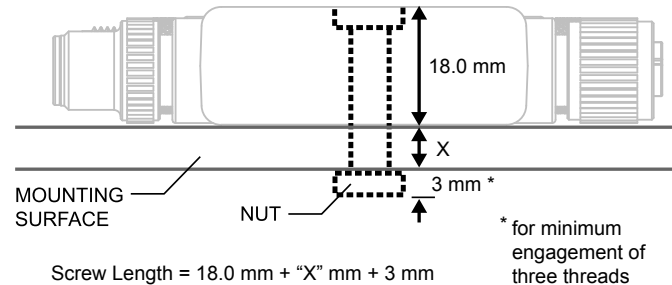

CAUTION: Do not overtighten the DXMR50-LB-2PA's mounting screw during installation. Overtightening can affect the performance of the DXMR50-LB-2PA.

Chapter Contents

DXMR50-LB-2PA Modbus Server IDs and Ports 21

Chapter 4 Modbus Overview

The DXMR50 Series Logic Blocks use internal 32-bit registers to store information. The processor's internal Local Registers serve as the main global pool of registers and are used as the common data exchange mechanism. External Modbus device registers can be read into the Local Registers or written from the local data registers.

The DXMR50 Series, as a Modbus client or server device, exchanges data using the Local Registers.

Using Action, Read/Write, and Threshold Rules allows you to manipulate the processor's Local Registers. The processor's Local Registers are divided into three different types: integer, floating point, and non-volatile. When using Local Registers internally, the user can store 32-bit numbers. Using Local Registers with external Modbus devices follows the Modbus standard of a 16-bit holding register. Local Registers are accessible as Modbus ID 199.

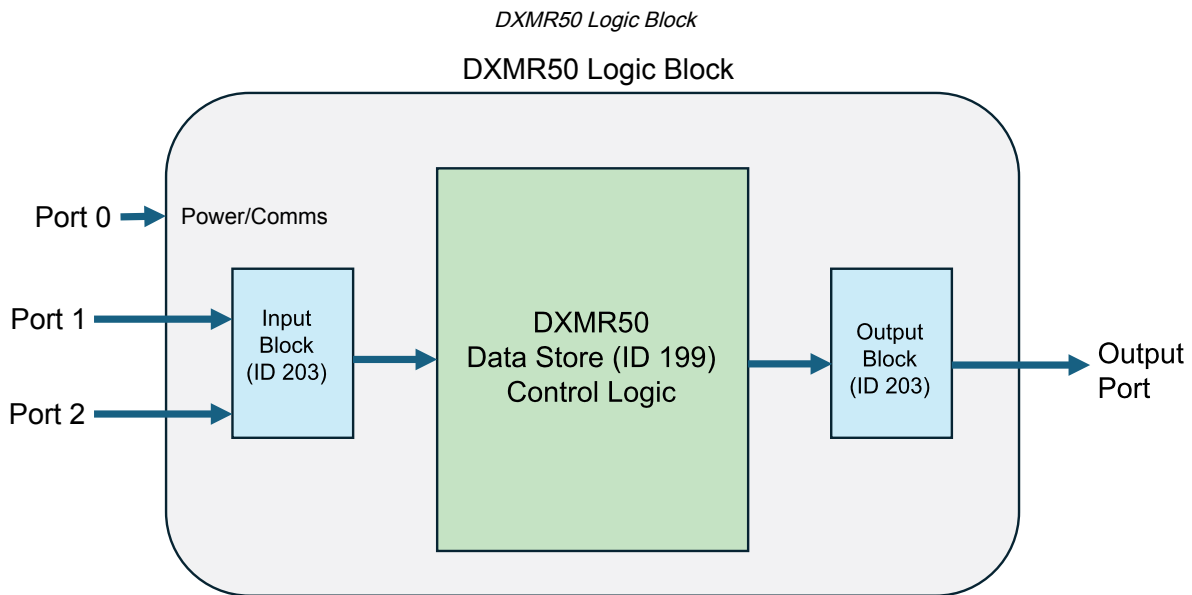

DXMR50-LB-2PA Modbus Server IDs and Ports

The DXMR50 Logic Block Series may have up to two internal Modbus server addresses:

Internal Modbus IDs (factory default)

Modbus ID	Device
199	Local Registers. Internal storage registers
203	LED Indicators

All Modbus registers are defined as 16-bit Modbus Holding Registers. The local register ID (199) is fixed for access. When accessing the Local Registers through an external Modbus RTU Client, use the male M12 (comms) port.

The Server Port ID can be changed using the DXMR50 Configuration Software. Connected Modbus server devices can use any Modbus ID.

Port 0 Signals (Comms)

Name	Port	Pin	Wire Color
Power (+)	0	1	Brown
RS-485+	0	2	White
Ground (-)	0	3	Blue
RS485-	0	4	Black

Input Port 1 and 2 Signals for models DXMR50-LB-2PA-2P/PI/PU

Name	Port	Pin	Wire Color		IO Block (ID 203) Register	Read Rule	Data Store (ID 199) Register
Power (+)	1	1	Brown				
Analog In	1	2	White	Voltage*	7	->	7
				Current*	8	->	8
Ground (-)	1	3	Blue				
PNP Discrete IN 1	1	4	Black		5		5
Power (+)	2	1	Brown				
Analog In	2	2	White	Voltage *	10		10
				Current*	11		11
Ground (-)	2	3	Blue				
PNP Discrete IN 2	2	4	Black		6		6

* Depend on the user's configuration.

Output Connections for models DXMR50-LB-2PA-PI/PU

Data Store (ID 199) Register		Write Rule	IO Block (ID 203) Register	Port	Pin	Wire Color	Name
				Out	1	Brown	Power (+)
13	Voltage	->	13	Out	2	White	Analog Out
14	Current	->	14				
				Out	3	Blue	Ground (-)
4	PNP Discrete OUT 1	->	4	Out	4	Black	PNP Discrete OUT 1

Output Connections for models DXMR50-LB-2PA-2P

Data Store (ID 199) Register		Write Rule	IO Block (ID 203) Register	Port	Pin	Wire Color	Name
				Out	1	Brown	Power (+)
2	PNP Discrete OUT 1	->	2	Out	2	White	PNP Discrete OUT1
				Out	3	Blue	Ground (-)
4	PNP Discrete OUT 2	->	4	Out	4	Black	PNP Discrete OUT 2

Chapter Contents

Brackets 23
 Cordsets 23

Chapter 5 Accessories

Brackets

<p>SMBR50</p> <ul style="list-style-type: none"> • R50 flat mount bracket • M4 x 0.7 mm • CAD Files: DXF, PDF, IGS, STP 	
---	--

Cordsets

4-Pin M12 Female RS-485 to USB Adapter Cordset, with Wall Plug				
Model	Length	Style	Product Image	Pinout (Female)
BWA-UCT-900	1 m (3.28 ft)	Straight		<p>1 = Brown 2 = White 3 = Blue 4 = Black</p>

4-pin A-Code Double-Ended M12 Female to M12 Male Cordsets (datasheet p/n 236186)				
Model	Length	Dimensions (mm)	Pinouts	
BC-M12F4-M12M4-22-1	1 m (3.28 ft)		<p>Female</p>	<p>1 = Brown 2 = White 3 = Blue 4 = Black 5 = Unused</p>
BC-M12F4-M12M4-22-2	2 m (6.56 ft)			
BC-M12F4-M12M4-22-3	3 m (9.84 ft)			
BC-M12F4-M12M4-22-4	4 m (13.12 ft)			
BC-M12F4-M12M4-22-5	5 m (16.4 ft)			
BC-M12F4-M12M4-22-10	10 m (30.81 ft)			
BC-M12F4-M12M4-22-15	15 m (49.2 ft)			
			<p>Male</p>	

4-pin A-Code Double-Ended M12 Female to M12 Male Right-Angle Cordsets (datasheet p/n 236186)				
Model	Length	Dimensions (mm)	Pinouts	
BC-M12F4-M12M4A-22-1	1 m (3.28 ft)		Female 	1 = Brown 2 = White 3 = Blue 4 = Black 5 = Unused
BC-M12F4-M12M4A-22-2	2 m (6.56 ft)			
BC-M12F4-M12M4A-22-5	5 m (16.4 ft)			
BC-M12F4-M12M4A-22-8	8 m (26.25 ft)			
BC-M12F4-M12M4A-22-10	10 m (30.81 ft)			
BC-M12F4-M12M4A-22-15	15 m (49.2 ft)		Male 	

4-pin A-Code Double-Ended M12 Female Right-Angle to M12 Male Right-Angle Cordsets (datasheet p/n 236186)				
Model	Length	Dimensions (mm)	Pinouts	
BC-M12F4A-M12M4A-22-0.3	0.3 m (1 ft)		Female 	1 = Brown 2 = White 3 = Blue 4 = Black 5 = Unused
BC-M12F4A-M12M4A-22-1	1 m (3.28 ft)			
BC-M12F4A-M12M4A-22-2	2 m (6.56 ft)			
BC-M12F4A-M12M4A-22-5	5 m (16.4 ft)			
BC-M12F4A-M12M4A-22-8	8 m (26.25 ft)			
BC-M12F4A-M12M4A-22-10	10 m (30.81 ft)			
BC-M12F4A-M12M4A-22-15	15 m (49.2 ft)		Male 	

Chapter Contents

Repairs	25
Contact Us	25
Banner Engineering Corp Limited Warranty	25

Chapter 6 Product Support and Maintenance

Repairs

Contact Banner Engineering for troubleshooting of this device. **Do not attempt any repairs to this Banner device; it contains no field-replaceable parts or components.** If the device, device part, or device component is determined to be defective by a Banner Applications Engineer, they will advise you of Banner's RMA (Return Merchandise Authorization) procedure.

IMPORTANT: If instructed to return the device, pack it with care. Damage that occurs in return shipping is not covered by warranty.

Contact Us

Banner Engineering Corp. | 9714 Tenth Avenue North | Plymouth, MN 55441, USA | Phone: + 1 888 373 6767

For worldwide locations and local representatives, visit www.bannerengineering.com.

Banner Engineering Corp Limited Warranty

Banner Engineering Corp. warrants its products to be free from defects in material and workmanship for one year following the date of shipment. Banner Engineering Corp. will repair or replace, free of charge, any product of its manufacture which, at the time it is returned to the factory, is found to have been defective during the warranty period. This warranty does not cover damage or liability for misuse, abuse, or the improper application or installation of the Banner product.

THIS LIMITED WARRANTY IS EXCLUSIVE AND IN LIEU OF ALL OTHER WARRANTIES WHETHER EXPRESS OR IMPLIED (INCLUDING, WITHOUT LIMITATION, ANY WARRANTY OF MERCHANTABILITY OR FITNESS FOR A PARTICULAR PURPOSE), AND WHETHER ARISING UNDER COURSE OF PERFORMANCE, COURSE OF DEALING OR TRADE USAGE.

This Warranty is exclusive and limited to repair or, at the discretion of Banner Engineering Corp., replacement. **IN NO EVENT SHALL BANNER ENGINEERING CORP. BE LIABLE TO BUYER OR ANY OTHER PERSON OR ENTITY FOR ANY EXTRA COSTS, EXPENSES, LOSSES, LOSS OF PROFITS, OR ANY INCIDENTAL, CONSEQUENTIAL OR SPECIAL DAMAGES RESULTING FROM ANY PRODUCT DEFECT OR FROM THE USE OR INABILITY TO USE THE PRODUCT, WHETHER ARISING IN CONTRACT OR WARRANTY, STATUTE, TORT, STRICT LIABILITY, NEGLIGENCE, OR OTHERWISE.**

Banner Engineering Corp. reserves the right to change, modify or improve the design of the product without assuming any obligations or liabilities relating to any product previously manufactured by Banner Engineering Corp. Any misuse, abuse, or improper application or installation of this product or use of the product for personal protection applications when the product is identified as not intended for such purposes will void the product warranty. Any modifications to this product without prior express approval by Banner Engineering Corp will void the product warranties. All specifications published in this document are subject to change; Banner reserves the right to modify product specifications or update documentation at any time. Specifications and product information in English supersede that which is provided in any other language. For the most recent version of any documentation, refer to: www.bannerengineering.com.

For patent information, see www.bannerengineering.com/patents.

