

S15L Pro In-Line RGB Indicator Instruction Manual



Original Instructions
p/n: 242116 Rev. A
April 18, 2024

© Banner Engineering Corp. All rights reserved.

Contents

Chapter 1 Features

Models	3
--------------	---

Chapter 2 Configuration Instructions

Pro Editor	4
Wiring	4
Pro Editor Configuration for the S15L	4

Chapter 3 Specifications

FCC Part 15 Class B for Unintentional Radiators	8
Industry Canada ICES-003(B)	8
Dimensions	9

Chapter 4 Accessories

Cordsets	10
Brackets	11
Quick-Disconnect Cap	11
Pro Editor Hardware	11

Chapter 5 Banner Engineering Corp Limited Warranty 13

Chapter Contents

Models 3

Chapter 1 Features

15 mm Multicolor RGB Indicator



- Bright, programmable indicator light with RGB LEDs
- Rugged overmolded indicator segment design meets IP65, IP67 and IP68
- Connect directly to a compatible sensor or anywhere in-line for easy visual indication
- Programmable color, flashing, and intensity settings

Models

Model	Housing	Style	Control	Connector
S15LPRGB7Q	S15	Pro	Discrete	Integral 5-pin M12 male/female quick-disconnect connector

Chapter Contents

Pro Editor 4
 Wiring 4
 Pro Editor Configuration for the S15L 4

Chapter 2 Configuration Instructions

Pro Editor

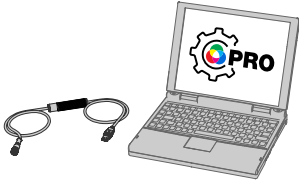

Use Banner's Pro Editor software and Pro Converter Cable to create custom configurations by selecting different colors, flash patterns, and animations. For more information visit www.bannerengineering.com/proeditor.

Wiring

5-pin M12 Male	5-pin M12 Female	Pin	Wire Color	Description
		1	Brown	Input 2: 12 V DC to 30 V DC
		2	White	Input 3: 12 V DC to 30 V DC
		3	Blue	DC Common
		4	Black	Input 1: 12 V DC to 30 V DC
		5	Gray	Input 4 (Default Flashing Input): 12 V DC to 30 V DC

Default Color Definition

	Red	Yellow	Green	Cyan	Blue	Magenta	White
Input 1	X	X				X	X
Input 2		X	X	X			X
Input 3				X	X	X	X

An "X" denotes an active input, for example when Input 1 and Input 3 are active, the indicator will show Magenta.

Pro Editor Configuration for the S15L

Banner's Pro Editor software offers an easy way to configure Pro Series-enabled touch and indicator devices, allowing users full control of device states. The easy-to-use configuration software provides a variety of tools and capabilities to solve a wide range of applications. Configure any Pro Series-enabled device using the free Pro Editor software, available for download at www.bannerengineering.com/proeditor.

Color 1 and Color 2 Options

Green	Yellow	Sky Blue	Rose
Red	Lime Green	Blue	White
Orange	Spring Green	Violet	Custom 1
Amber	Cyan	Magenta	Custom 2

Intensity 1 or Intensity 2 Options

Intensity	Description
High	100%
Medium	60%
Low	25%
Off	0%
Custom	Set a custom intensity percentage

Animation Settings

Animation	Description
Off	Device OFF, no animation displays
Steady	Color 1 is solid ON at the defined intensity
Flash	Color 1 flashes at the defined speed, color intensity, and pattern (normal, strobe, three pulse, SOS, or random)
Two Color Flash	Color 1 and Color 2 flash alternately at the defined speed, color intensities, and pattern (normal, strobe, three pulse, SOS, or random)
50/50	Color 1 is displayed on one side of the indicator and Color 2 is displayed on the other side of the indicator at the defined color intensities
50/50 Rotate	Color 1 is displayed on one side of the indicator and Color 2 is displayed on the other side of the indicator while alternating sides at the defined speed and color intensities
Intensity Sweep	Color 1 continuously increases and decreases intensity between 0% to 100% at defined speed and color intensity
Color Sweep	Color 1 and Color 2 define the end values of a line across the color gamut. The light continuously displays a color by moving along the line at the defined speed and color intensity
Wave	Color 1 increases and decreases intensity between 0% to 100% at defined speed and color intensity on one side of the indicator, then switches to other side of indicator; then Color 2 repeats same sequence
Double Wave	Color 1 increases intensity between 0% to 100% at defined speed and color intensity holding on one side of the indicator, then the other side of indicator increases intensity between 0% to 100%; then Color 2 repeats same sequence

Pulse Patterns

Pattern	Description
Normal	Alternating Color 1; Off or Color 2 at 50% duty cycle
Strobe	Continuous Color 1; Off or Color 2 flashes at 20% duty cycle
3-Pulse	Three consecutive Color 1 pulses at 10% duty cycle on Off or Color 2 background
SOS	Short pulse, short pulse, short pulse, long pulse, long pulse, long pulse, short pulse, short pulse, short pulse alternating Color 1 and Off or Color 2
Random	Random sequence of Color 1 and Off or Color 2 flashes

Speed

Speed	Description
Slow	0.5 Hz
Medium	1 Hz
Fast	5 Hz
Custom Flash Rate	Set a custom flash rate in Hz

The three **I/O states** available in Pro Editor are:

I/O State Configuration Settings	Description
Basic	Configurations made in this state assign one wire to one state, with the following override control: <ul style="list-style-type: none">• Pin 1 (Brown) overrides Pin 4 (Black)• Pin 2 (White) overrides Pins 1 and 4 (Brown and Black)• Pin 5 (Gray) overrides Pins 1, 2, and 4 (Brown, White, and Black)
Advanced	I/O state with full fifteen state options for maximum configuration. Configurations made in Advanced assign binary wiring combinations of all valid inputs to each state.
I/O Block	Three state control for use with I/O block. Configurations made in I/O Block assign states to the black, white, and combination of black and white wires for use with I/O blocks for which power (brown) and common (blue) are always on for five pin connections.

Chapter Contents

FCC Part 15 Class B for Unintentional Radiators 8
 Industry Canada ICES-003(B)..... 8
 Dimensions..... 9

Chapter 3 Specifications

Supply Voltage

12 V DC to 30 V DC

Supply Current

60 mA maximum current at 12 V DC

35 mA typical at 24 V DC

Supply Protection Circuitry

Protected against reverse polarity and transient voltages

Leakage Current Immunity

400 µA

Input Response Time

250 milliseconds maximum

Flash

Default 1 Hz flash rate through flash input wire

Operating Conditions

−40 °C to +45 °C (−40 °F to +113 °F)

Humidity: 90% at +50 °C maximum relative humidity (non-condensing)

Storage Temperature: −40 °C to +70 °C (−40 °F to +158 °F)

Environmental Rating

IP65, IP67, IP68, UL Type 1

Construction

Coupling Material: Nickel-plated brass

Connector Body: PVC diffuse white

Vibration and Mechanical Shock

Meets IEC 60068-2-6 requirements (Vibration: 10 Hz to 55 Hz, 0.5 mm amplitude, 5 minutes sweep, 30 minutes dwell)

Meets IEC 60068-2-27 requirements (Shock: 15G 11 ms duration, half sine wave)

Connections

Integral 5-pin M12 male/female quick-disconnect connector

Models with a quick disconnect require a mating cordset

Required Overcurrent Protection



WARNING: Electrical connections must be made by qualified personnel in accordance with local and national electrical codes and regulations.

Overcurrent protection is required to be provided by end product application per the supplied table.

Overcurrent protection may be provided with external fusing or via Current Limiting, Class 2 Power Supply.

Supply wiring leads < 24 AWG shall not be spliced.

For additional product support, go to www.bannerengineering.com.

Supply Wiring (AWG)	Required Overcurrent Protection (A)	Supply Wiring (AWG)	Required Overcurrent Protection (A)
20	5.0	26	1.0
22	3.0	28	0.8
24	1.0	30	0.5

Certifications

 Banner Engineering BV
 Park Lane, Culliganlaan 2F bus 3
 1831 Diegem, BELGIUM

 Turck Banner LTD Blenheim House
 Blenheim Court
 Wickford, Essex SS11 8YT
 GREAT BRITAIN

 **UL** US
 LISTED

Default Indicator Characteristics

Color	Dominant Wavelength (nm) or Color Temperature (CCT)	Color Coordinates ⁽¹⁾		Lumen Output (Typical at 25 °C)
		x	y	
White	7000K	0.31	0.295	1.16
Green	527	0.175	0.7	1.8
Red	620	0.69	0.307	1.3
Orange	604	0.628	0.356	1.35
Amber	597	0.593	0.383	1.35
Yellow	588	0.537	0.426	1.35
Lime Green	577	0.466	0.481	1.8
Spring Green	513	0.178	0.562	1.6
Cyan	498	0.195	0.396	1.3
Sky Blue	489	0.17	0.303	1.1
Blue	465	0.144	0.055	0.25
Violet	-	0.337	0.144	0.7
Magenta	-	0.506	0.251	1
Rose	-	0.593	0.282	1.1

FCC Part 15 Class B for Unintentional Radiators

(Part 15.105(b)) This equipment has been tested and found to comply with the limits for a Class B digital device, pursuant to part 15 of the FCC Rules. These limits are designed to provide reasonable protection against harmful interference in a residential installation. This equipment generates, uses, and can radiate radio frequency energy and, if not installed and used in accordance with the instructions, may cause harmful interference to radio communications. However, there is no guarantee that interference will not occur in a particular installation. If this equipment does cause harmful interference to radio or television reception, which can be determined by turning the equipment off and on, the user is encouraged to try to correct the interference by one or more of the following measures:

- Reorient or relocate the receiving antenna.
- Increase the separation between the equipment and receiver.
- Connect the equipment into an outlet on a circuit different from that to which the receiver is connected.
- Consult the dealer or an experienced radio/TV technician for help.

(Part 15.21) Any changes or modifications not expressly approved by the party responsible for compliance could void the user's authority to operate this equipment.

Industry Canada ICES-003(B)

This device complies with CAN ICES-3 (B)/NMB-3(B). Operation is subject to the following two conditions: 1) This device may not cause harmful interference; and 2) This device must accept any interference received, including interference that may cause undesired operation.

Cet appareil est conforme à la norme NMB-3(B). Le fonctionnement est soumis aux deux conditions suivantes : (1) ce dispositif ne peut pas occasionner d'interférences, et (2) il doit tolérer toute interférence, y compris celles susceptibles de provoquer un fonctionnement non souhaité du dispositif.

⁽¹⁾ Refer to the CIE 1931 (x,y) Chromaticity Diagram to show equivalent color with indicated color coordinates. Actual coordinates may differ ± 5%.

Dimensions

All measurements are listed in millimeters [inches], unless noted otherwise.

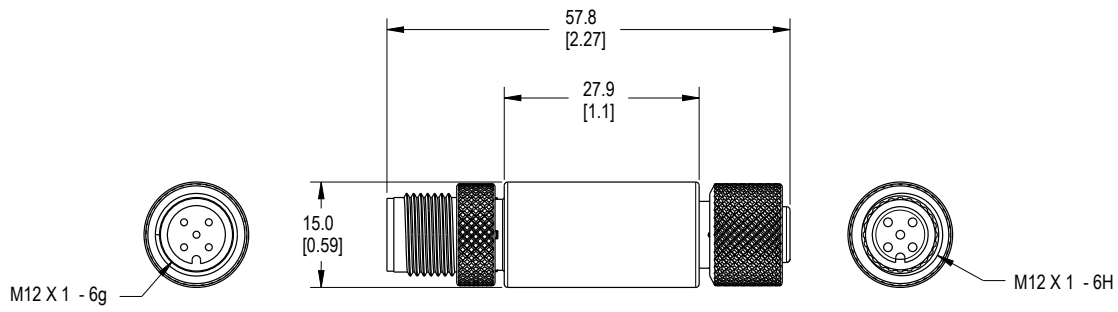

Chapter Contents

Cordsets 10
 Brackets 11
 Quick-Disconnect Cap..... 11
 Pro Editor Hardware..... 11

Chapter 4 Accessories

Cordsets

5-Pin Threaded M12 Cordsets—Single Ended				
Model	Length	Style	Dimensions	Pinout (Female)
MQDC1-501.5	0.5 m (1.5 ft)	Straight		<p>1 = Brown 2 = White 3 = Blue 4 = Black 5 = Gray</p>
MQDC1-503	0.9 m (2.9 ft)			
MQDC1-506	2 m (6.5 ft)			
MQDC1-515	5 m (16.4 ft)			
MQDC1-530	9 m (29.5 ft)			
MQDC1-560	18 m (59 ft)			
MQDC1-5100	31 m (101.7 ft)	Right-Angle		<p>1 = Brown 2 = White 3 = Blue 4 = Black 5 = Gray</p>
MQDC1-506RA	2 m (6.5 ft)			
MQDC1-515RA	5 m (16.4 ft)			
MQDC1-530RA	9 m (29.5 ft)			
MQDC1-560RA	19 m (62.3 ft)			

5-Pin Threaded M12 Cordsets—Double Ended					
Model	Length	Style	Dimensions	Pinout (Male)	Pinout (Female)
MQDEC-501SS	0.31 m (1.02 ft)	Male Straight/ Female Straight		<p>1 = Brown 2 = White 3 = Blue</p>	<p>4 = Black 5 = Gray</p>
MQDEC-503SS	0.91 m (2.99 ft)				
MQDEC-506SS	1.83 m (6 ft)				
MQDEC-512SS	3.66 m (12 ft)				
MQDEC-515SS	5 m (16.4 ft)				
MQDEC-530SS	9 m (29.5 ft)				
MQDEC-550SS	15 m (49.2 ft)				

Brackets

LMBM12MAG

- Attaches to M12 cordset end
- Black polypropylene
- 11.8 kg (26 lb) pull force
- One piece

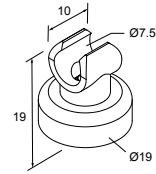

LMBM12SP

- Attaches to M12 cordset end
- Black polypropylene
- Supplied with thread-forming hardware
- Pack of seven

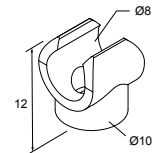

LMBS15MAG

- Attaches to S15 housing
- White polypropylene
- 11.8 kg (26 lb) pull force
- One piece

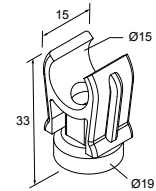

LMBS15SP

- Attaches to S15 housing
- White polypropylene
- Clearance for M5 or #10 hardware
- Pack of five

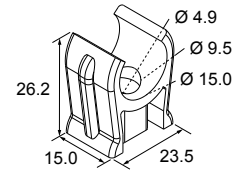

Quick-Disconnect Cap

ACC-CAP M12-10

- 10 Caps
- Seal and protect exposed, unterminated cascade quick-disconnect connectors

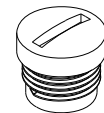

Pro Editor Hardware

PRO-KIT

Includes:

- Pro Converter Cable (MQDC-506-USB)
- Splitter (CSB-M1251FM1251M)
- Power Supply (PSW-24-1)

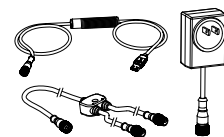

MQDC-506-USB

- Pro Converter Cable
- 1.83 m (6 ft) length 5-pin M12 quick disconnect to Device and USB to PC
- Required for connection to Pro Editor

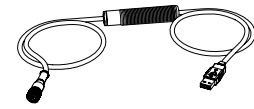
**CSB-M1251FM1251M**

- 5-pin parallel Y splitter (Male-Male-Female)
- For full Pro Editor preview capability
- Requires external power supply, sold separately

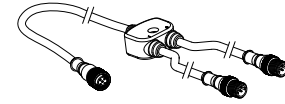
**PSW-24-1**

- 24 V DC, 1 A power supply
- 2 m (6.5 ft) PVC cable with M12 quick disconnect
- Provides external power with splitter cable, sold separately

**PSW-24-2**

- 24 V DC, 2 A Class 2 UL Listed power supply
- 100 V AC to 240 V AC 50/60 Hz input
- 3.5 m (11.5 ft) PVC cable with M12 quick disconnect
- Includes Type A (US, Canada, Japan, Puerto Rico, Taiwan), Type C (Germany, France, South Korea, Netherlands, Poland, Spain, Turkey), Type G (United Kingdom, Ireland, Singapore, Vietnam), and Type I (China, Australia, New Zealand) AC detachable input plugs

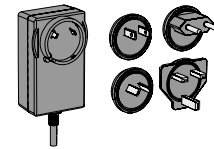
**ACC-PRO-CABLE5**

- Mating accessory for cabled and terminal models
- 150 mm (6 inch) PVC cable with M12 quick disconnect
- Lever wire nuts included (qty 5)
- Required to connect cabled models and screw terminal models to Pro Converter Cable, sold separately

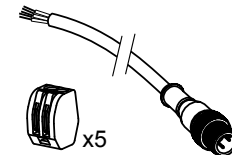

Chapter Contents

Chapter 5 Banner Engineering Corp Limited Warranty

Banner Engineering Corp. warrants its products to be free from defects in material and workmanship for one year following the date of shipment. Banner Engineering Corp. will repair or replace, free of charge, any product of its manufacture which, at the time it is returned to the factory, is found to have been defective during the warranty period. This warranty does not cover damage or liability for misuse, abuse, or the improper application or installation of the Banner product.

THIS LIMITED WARRANTY IS EXCLUSIVE AND IN LIEU OF ALL OTHER WARRANTIES WHETHER EXPRESS OR IMPLIED (INCLUDING, WITHOUT LIMITATION, ANY WARRANTY OF MERCHANTABILITY OR FITNESS FOR A PARTICULAR PURPOSE), AND WHETHER ARISING UNDER COURSE OF PERFORMANCE, COURSE OF DEALING OR TRADE USAGE.

This Warranty is exclusive and limited to repair or, at the discretion of Banner Engineering Corp., replacement. **IN NO EVENT SHALL BANNER ENGINEERING CORP. BE LIABLE TO BUYER OR ANY OTHER PERSON OR ENTITY FOR ANY EXTRA COSTS, EXPENSES, LOSSES, LOSS OF PROFITS, OR ANY INCIDENTAL, CONSEQUENTIAL OR SPECIAL DAMAGES RESULTING FROM ANY PRODUCT DEFECT OR FROM THE USE OR INABILITY TO USE THE PRODUCT, WHETHER ARISING IN CONTRACT OR WARRANTY, STATUTE, TORT, STRICT LIABILITY, NEGLIGENCE, OR OTHERWISE.**

Banner Engineering Corp. reserves the right to change, modify or improve the design of the product without assuming any obligations or liabilities relating to any product previously manufactured by Banner Engineering Corp. Any misuse, abuse, or improper application or installation of this product or use of the product for personal protection applications when the product is identified as not intended for such purposes will void the product warranty. Any modifications to this product without prior express approval by Banner Engineering Corp will void the product warranties. All specifications published in this document are subject to change; Banner reserves the right to modify product specifications or update documentation at any time. Specifications and product information in English supersede that which is provided in any other language. For the most recent version of any documentation, refer to: www.bannerengineering.com.

For patent information, see www.bannerengineering.com/patents.

 [LinkedIn](#)

 [Twitter](#)

 [Facebook](#)

