

LC25 LED Controller with IO-Link Instruction Manual



Original Instructions
p/n: 234629 Rev. B
March 13, 2024

© Banner Engineering Corp. All rights reserved.

Contents

Chapter 1 LC25 LED Controller Features

LC25 LED Controller Models	3
----------------------------------	---

Chapter 2 Configuration Instructions

LC25 LED Controller with WLF12 Wiring	4
LC25 LED Controller with IO-Link Process Data Out (Master to Device)	4

Chapter 3 LC25 LED Controller Specifications

FCC Part 15 Class A for Unintentional Radiators	9
Industry Canada ICES-003(A)	9
LC25 LED Controller Dimensions	9

Chapter 4 LC25 LED Controller Accessories 10

Chapter 5 Banner Engineering Corp Limited Warranty

Document Information	14
----------------------------	----

Chapter Contents

LC25 LED Controller Models..... 3

Chapter 1 LC25 LED Controller Features

Banner's LC25 LED Controller is designed to work with the WLF12 Pro Flexible Multicolor Strip Light product family. It has a low profile, rugged, water-resistant design, making the LC25 ideal for indoor and outdoor applications.

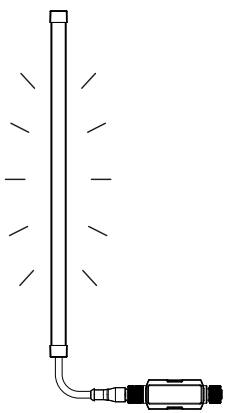
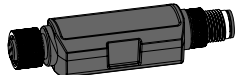
	<ul style="list-style-type: none"> • In-line controller with M12 connectors • Industrial controller between the WLF12 Pro and an IO-Link master • IP65, IP67, and IP68 housing simplifies installation in any location by eliminating the need for a control cabinet • Rugged waterproof and dustproof overmolded design • Voltage rating of 18 to 30 V DC 	
---	---	---

IMPORTANT: Read the following instructions before operating the light. Please download the complete LC25 LED Controller technical documentation, available in multiple languages, from www.bannerengineering.com for details on the proper use, applications, Warnings, and installation instructions of this device.

IMPORTANT: Lea el siguiente instructivo antes de operar el luminario. Por favor descargue desde www.bannerengineering.com toda la documentación técnica de los LC25 LED Controller, disponibles en múltiples idiomas, para detalles del uso adecuado, aplicaciones, advertencias, y las instrucciones de instalación de estos dispositivos.

IMPORTANT: Lisez les instructions suivantes avant d'utiliser le luminaire. Veuillez télécharger la documentation technique complète des LC25 LED Controller sur notre site www.bannerengineering.com pour les détails sur leur utilisation correcte, les applications, les notes de sécurité et les instructions de montage.

LC25 LED Controller Models

Model	For Use With
LC25C-WLF12-KQ	WLF12 Pro Flexible Multicolor Strip Light

Chapter Contents

LC25 LED Controller with WLF12 Wiring 4
 LC25 LED Controller with IO-Link Process Data Out (Master to Device) 4

Chapter 2 Configuration Instructions

LC25 LED Controller with WLF12 Wiring

LED Controller with IO-Link Wiring

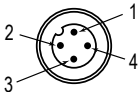
4-pin Male M12 Pinout	Pinout Key and Wiring
	<ol style="list-style-type: none"> 1. Brown - 18 V DC to 30 V DC 2. White - Not used 3. Blue - DC Common 4. Black - IO-Link Communication

LC25 LED Controller with IO-Link Process Data Out (Master to Device)

IO-Link® is a point-to-point communication link between a master device and a sensor and/or light. It can be used to automatically parameterize sensors or lights and to transmit process data. For the latest IO-LINK protocol and specifications, please visit www.io-link.com.

For the latest IODD files, please refer to the Banner Engineering Corp website at: www.bannerengineering.com.

Segment Mode

Configure the light to have up to 10 segments that scale in size automatically with the length of the light or select Manual Segment Configuration which allows each segment to have a custom LED width and LED offset from the beginning of each segment to the beginning of the light.

Use process data to set each segment to off, solid on, flash, or animation mode. Use parameter data to change segment number and configuration, color, intensity, flash speed, direction, background, threshold markers, and select animation type.

Animation	Description
Off	Segment is off
Steady	Color 1 is on at the defined intensity
Flash	Color 1 flashes at the defined speed, color intensity, and pattern (normal, strobe, three pulse, SOS, or random)
Two Color Flash	Color 1 and Color 2 flash alternately at the defined speed, color intensities, and pattern (normal, strobe, three pulse, SOS, or random)
Two Color Shift	Color 1 and Color 2 flash alternately on adjacent LEDs at the defined speed and color intensities
Ends Steady	Color 1 is on in the center of the segment as defined by Percent Width of Color 1 at defined color intensity while Color 2 is solid on for half of the remaining percentage on each end of the segment at defined color intensity
Ends Flash	Color 1 is on in the center of the segment as defined by Percent Width of Color 1 at defined color intensity while Color 2 flashes on for half of the remaining percentage on each end of the segment at the defined speed, color intensity, and pattern (normal, strobe, three pulse, SOS, or random)
Scroll	Color 1 fills the segment as defined by Percent Width of Color 1 and moves in one direction up or down against the background of Color 2 at the defined speed, color intensities, style, and direction
Center Scroll	Color 1 fills the segment as defined by Percent Width of Color 1 and moves in or out from the center of the segment against the background of Color 2 at the defined speed, color intensities, style, and direction
Bounce	Color 1 fills the segment as defined by Percent Width of Color 1 and moves up and down against the background of Color 2 at the defined speed, color intensities, and style

Continued on page 5

Continued from page 4

Animation	Description
Center Bounce	Color 1 fills the segment as defined by Percent Width of Color 1 and moves in and out from the center of the segment against the background of Color 2 at the defined speed, color intensities, and style
Intensity Sweep	Color 1 repeatedly increases and decreases intensity between 0% to 100% at the defined speed and color intensity
Two Color Sweep	Color 1 and Color 2 define the end values of a line across the color gamut. The segment continuously displays a color by moving along the line at the defined speed and color intensities
Spectrum	The segment scrolls through 13 predefined colors with a different color on each LED at the defined speed, Color 1 intensity, and direction
Single End Steady	Color 1 is solid ON at the defined intensity on one end of the device
Single End Flash	Color 1 flashes at the defined speed, color intensity, and pattern (normal, strobe, three pulse, SOS, or random) on one end of the device

Run Mode

Use process data to control the entire light and select color, intensity, flash, direction, and animations. Use parameter data to create custom colors, intensity, and flash speeds.

Animation	Description
Off	Light is off
Steady	Color 1 is on at the defined intensity
Flash	Color 1 flashes at the defined speed, color intensity, and pattern (normal, strobe, three pulse, SOS, or random)
Two Color Flash	Color 1 and Color 2 flash alternately at the defined speed, color intensities, and pattern (normal, strobe, three pulse, SOS, or random)
Two Color Shift	Color 1 and Color 2 flash alternately on adjacent LEDs at the defined speed and color intensities
Ends Steady	Color 1 is on in the center of the light as defined by Percent Width of Color 1 at the defined color intensity while Color 2 is on for half of the remaining percentage on each end of the light at the defined color intensity
Ends Flash	Color 1 is on in the center of the light as defined by Percent Width of Color 1 at defined color intensity while Color 2 flashes for half of the remaining percentage on each end of the light at defined speed, color intensity, and pattern (normal, strobe, three pulse, SOS, or random)
Scroll	Color 1 fills the light as defined by Percent Width of Color 1 and moves in one direction up or down against the background of Color 2 at the defined speed, color intensities, style, and direction
Center Scroll	Color 1 fills the light as defined by Percent Width of Color 1 and moves in or out from the center of the light against the background of Color 2 at the defined speed, color intensities, style, and direction
Bounce	Color 1 fills the light as defined by Percent Width of Color 1 and moves up and down against the background of Color 2 at the defined speed, color intensities, and style
Center Bounce	Color 1 fills the light as defined by Percent Width of Color 1 and moves in and out from the center of the light against the background of Color 2 at the defined speed, color intensities, and style
Intensity Sweep	Color 1 repeatedly increases and decreases intensity between 0% to 100% at defined speed and color intensity
Two Color Sweep	Color 1 and Color 2 define the end values of a line across the color gamut. The light continuously displays a color by moving along the line at the defined speed and color intensities
Spectrum	The light scrolls through 13 predefined colors with a different color on each LED at the defined speed, Color 1 intensity, and direction
Single End Steady	Color 1 is on at the defined intensity on one end of the device
Single End Flash	Color 1 flashes at the defined speed, color intensity, and pattern (normal, strobe, three pulse, SOS, or random) on one end of the device

Level Mode

Use process data to set the level value. Use parameter data to set range, thresholds, colors, intensities, flash speeds, background, threshold markers, and animation types.

General Settings	Description
Level Mode Value	Value of the level of the light (between 0 to 65,535)
Full Scale Value	Set the upper limit of the Level Mode Value (between 0 to 65,535)

Continued on page 6

Continued from page 5

General Settings	Description
Background Color and Intensity	A defined color and intensity is displayed on LEDs that are not active
Dominance	Dominant: The entire light displays the active threshold color Non-Dominant: LEDs display their defined threshold colors
Sub-Segment Style	If Level Mode Value is a partial percentage of an LED, select if the segment will be on steady or analog dimmed to the partial percentage
Filtering	Smooths the input signal by varying the sample size None: There is no filtering Low: The sample size is short and changes to the input signal are more noticeable High: The sample size is long and changes to the input signal are less noticeable
Hysteresis	Determines the signal value change needed to transition between thresholds and to prevent chatter None: The value follows the input signal High: A large value change is needed to transition between thresholds
Level Mode Threshold Markers	Threshold markers display LED(s) at the defined thresholds and can be configured as either dominant or non-dominant. Threshold marker location and width are defined by the offset and width parameters, respectively, in segment mode.

Base and Threshold 1-4 Settings	Description
Threshold Type: Base	A defined animation state is displayed on LEDs that are not defined within a threshold
Threshold Type: 1-4	Level Mode Values that conform to Threshold Comparison Type \leq or \geq and the Threshold Value Percent are displayed on LEDs as defined by the threshold color, intensity, flash speeds, and run mode animation types

Dim and Blend Mode

Dim and blend mode uses the light to finely adjust the intensity of one color, or blend between two or three colors. Use process data to set the dim and blend mode value. Use parameter data to set number of colors, range, colors, and intensities.

General Settings	Description
Dim and Blend Mode Value	Value of the intensity of the light in 1 Color mode or value of the blend between colors in 2 and 3 Color mode (between 0 to 65,535)
Full Scale Value	Set the upper limit of the Dim and Blend Mode Value (between 0 to 65,535)
Number of Colors	1: Color 1 is on at the intensity defined by the percentage of Dim and Blend Mode Value to the Full Scale Value when Color 1 Intensity is set to high 2: Color 1 and Color 2 define the end values of a line across the color gamut. The light displays a blended color and moves along the line as defined by the Dim and Blend Mode Value and color intensities. 3: Color 1 and Color 2 define the beginning and end value of one line across the color gamut. Color 2 and Color 3 define the beginning and end value of a second line across the color gamut. The light displays a blended color and moves along the two lines as defined by the Dim and Blend Mode Value and color intensities.
Filtering	Smooths the input signal by varying the sample size None: There is no filtering Low: The sample size is short and changes to the input signal are more noticeable High: The sample size is long and changes to the input signal are less noticeable

Gauge Mode

Gauge mode uses the light to display a colored band of LEDs in a position proportional to the gauge mode value. Use process data to set the gauge mode value. Use parameter data to set range, thresholds, colors, intensities, flash speeds, background, threshold markers, and animation types.

General Settings	Description
Gauge Mode Value	Value of the band position within the light (between 0 to 65,535)
Full Scale Value	Set the upper limit of the Gauge Mode Value (between 0 to 65,535)
Filtering	Smooths the input signal by varying the sample size None: There is no filtering Low: The sample size is short and changes to the input signal are more noticeable High: The sample size is long and changes to the input signal are less noticeable

Continued on page 7

Continued from page 6

General Settings	Description
Hysteresis	Determines the signal value change needed to transition between thresholds and to prevent chatter None: The value follows the input signal High: A large value change is needed to transition between thresholds
Gauge Mode Threshold Markers	Threshold markers display LED(s) at the defined thresholds and can be configured as either dominant or non-dominant. Threshold marker location and width are defined by the offset and width parameter, respectively, in segment mode.

Center, Threshold 1, and Threshold 2 Settings	Description
Threshold Type: Center	Gauge Mode Values not in Threshold 1 or Threshold 2 are positioned on a band of LEDs as defined by the center threshold color, intensity, flash speeds, backgrounds, band size percent width, and run mode animation types
Threshold Type: 1 & 2	Gauge Mode Values that conform to Threshold Comparison Type \leq or \geq and the Threshold Value Percent are positioned on a band of LEDs as defined by the threshold color, intensity, flash speeds, backgrounds, band size percent width, and run mode animation types

LED Mode (Segment of Three LEDs)

Use process data to turn on and select a color for each segment of three LEDs. Use parameter data to set global intensity.

General Settings	Description
Segment 1-64 Color	Set chosen LED to off or to a defined color
Segment Mode Intensity	Defines intensity of all LEDs turned on

Demo Mode

Demonstrate sequence cycles through 12 different configurations to highlight example applications.

IMPORTANT: Set the number of LED Sections manually in the parameter data or run the LED Section Remote TEACH function to automatically program the number of LED sections.

Chapter Contents

FCC Part 15 Class A for Unintentional Radiators..... 9
 Industry Canada ICES-003(A)..... 9
 LC25 LED Controller Dimensions 9

Chapter 3 LC25 LED Controller Specifications

Supply Voltage

18 V DC to 30 V DC at 30 mA maximum
 Use only with a suitable Class 2 power supply (UL) or a SELV power supply (CE)
 See the WLF12 Pro Flexible Multicolor Strip Light Instruction Manual for the WLF12 supply voltage and current.
 Different IO-Link masters have different maximum current limits. Use the **CSB-M1251FM1251M** splitter cable and an external power supply if needed. See Accessories.

NOTICE: The WLF12 is designed to be used with an LC25 and must be no more than 3.05 m (10 ft) apart. Contact the factory for instructions on how to use a WLF12 without an LC25.

WARNING: The WLF12 will be permanently damaged if a supply voltage of greater than 12 V DC is applied directly to the light.

Supply Protection Circuitry

Protected against reverse polarity and transient voltages

Connections

Integral 4-pin M12 male and female quick-disconnect connectors

Mounting

A strip of double-sided very high bonding strength tape is supplied
 Multiple bracket options available
 Secure cables within 150 mm (5.9 in) of the light

Environmental Rating

IP65, IP67, IP68
 Suitable for wet locations per UL 2108
 Do not spray cable with a high-pressure sprayer or cable damage will result.

Input Response Time

45 ms maximum

Construction

Connector Body: PVC translucent black
 Coupling Material: Nickel-plated brass

Indicators

Green: Power
 Yellow: IO-Link communication

Vibration and Mechanical Shock

Vibration: 10 Hz to 55 Hz, 1.0 mm peak-to-peak amplitude per IEC 60068-2-6
 Shock: 15G 11 ms duration, half sine wave per IEC 60068-2-27

Operating Temperature

-40 °C to +50 °C (-40 °F to +122 °F)

Storage Temperature: -40 °C to +70 °C (-40 °F to +158 °F)

Certifications

CE Banner Engineering BV
 Park Lane, Culliganlaan 2F bus 3
 1831 Diegem, BELGIUM

UK CA Turck Banner LTD Blenheim House
 Blenheim Court
 Wickford, Essex SS11 8YT
 GREAT BRITAIN

UL LISTED

IO-Link®

Required Overcurrent Protection

WARNING: Electrical connections must be made by qualified personnel in accordance with local and national electrical codes and regulations.

Overcurrent protection is required to be provided by end product application per the supplied table.

Overcurrent protection may be provided with external fusing or via Current Limiting, Class 2 Power Supply.

Supply wiring leads < 24 AWG shall not be spliced.

For additional product support, go to www.bannerengineering.com.

Supply Wiring (AWG)	Required Overcurrent Protection (A)	Supply Wiring (AWG)	Required Overcurrent Protection (A)
20	5.0	26	1.0
22	3.0	28	0.8
24	1.0	30	0.5

FCC Part 15 Class A for Unintentional Radiators

This equipment has been tested and found to comply with the limits for a Class A digital device, pursuant to Part 15 of the FCC Rules. These limits are designed to provide reasonable protection against harmful interference when the equipment is operated in a commercial environment. This equipment generates, uses, and can radiate radio frequency energy and, if not installed and used in accordance with the instruction manual, may cause harmful interference to radio communications. Operation of this equipment in a residential area is likely to cause harmful interference in which case the user will be required to correct the interference at his own expense.

(Part 15.21) Any changes or modifications not expressly approved by the party responsible for compliance could void the user's authority to operate this equipment.

Industry Canada ICES-003(A)

This device complies with CAN ICES-3 (A)/NMB-3(A). Operation is subject to the following two conditions: 1) This device may not cause harmful interference; and 2) This device must accept any interference received, including interference that may cause undesired operation.

Cet appareil est conforme à la norme NMB-3(A). Le fonctionnement est soumis aux deux conditions suivantes : (1) ce dispositif ne peut pas occasionner d'interférences, et (2) il doit tolérer toute interférence, y compris celles susceptibles de provoquer un fonctionnement non souhaité du dispositif.

LC25 LED Controller Dimensions

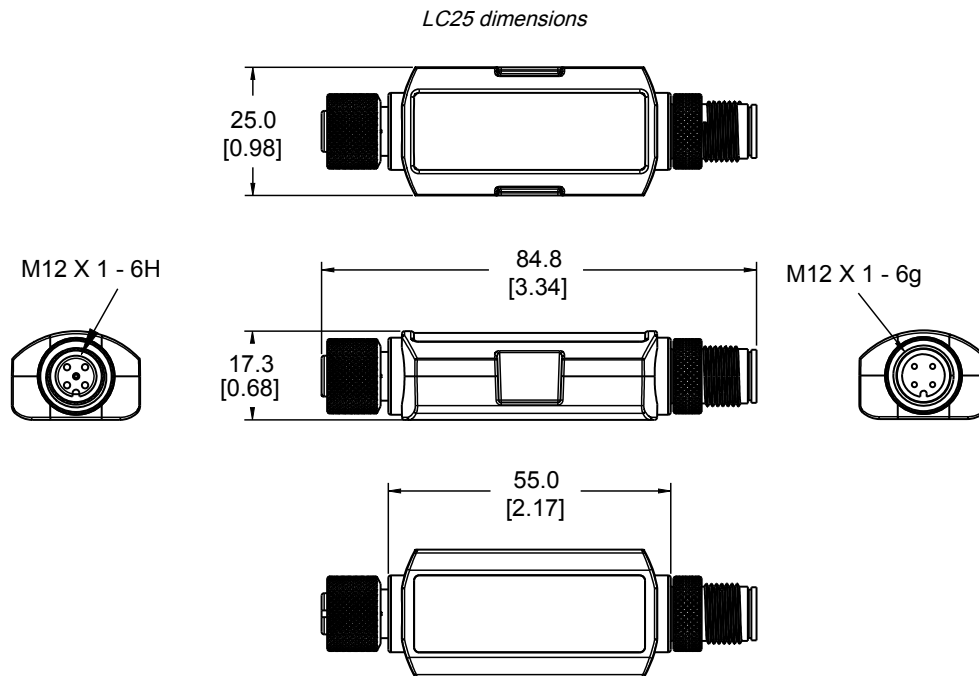

Chapter Contents

Chapter 4 LC25 LED Controller Accessories

LMBLC25T

- Stainless steel clip bracket
- Includes 1 clip bracket and 2 plastic spacers
- Clearance hole for M5 hardware

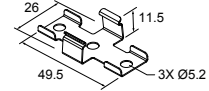

LMBLC25TMAG

- Magnetic mounting bracket for attachment to steel and iron surfaces

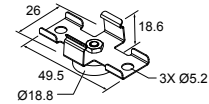

4-Pin Threaded M12 Cordsets—Single Ended

Model	Length	Style	Dimensions	Pinout (Female)
MQDC-406	2 m (6.56 ft)	Straight		
MQDC-415	5 m (16.4 ft)			
MQDC-430	9 m (29.5 ft)			
MQDC-450	15 m (49.2 ft)	Right-Angle		
MQDC-406RA	2 m (6.56 ft)			
MQDC-415RA	5 m (16.4 ft)			
MQDC-430RA	9 m (29.5 ft)			
MQDC-450RA	15 m (49.2 ft)			<p>1 = Brown 2 = White 3 = Blue 4 = Black 5 = Unused</p>







4-Pin Threaded M12 Cordsets—Double Ended				
Model	Length	Style	Dimensions	Pinout
MQDEC-401SS	0.31 m (1 ft)	Male Straight / Female Straight		<p>Female</p>
MQDEC-403SS	0.91 m (2.99 ft)			
MQDEC-406SS	1.83 m (6 ft)			
MQDEC-412SS	3.66 m (12 ft)			
MQDEC-415SS	4.58 m (15 ft)			
MQDEC-420SS	6.10 m (20 ft)			
MQDEC-430SS	9.14 m (30.2 ft)			
MQDEC-450SS	15.2 m (49.9 ft)			
MQDEC-403RS	0.91 m (2.99 ft)	Male Right-Angle / Female Straight		<p>Male</p> <p>1 = Brown 2 = White 3 = Blue 4 = Black</p>
MQDEC-406RS	1.83 m (6 ft)			
MQDEC-412RS	3.66 m (12 ft)			
MQDEC-420RS	6.10 m (20 ft)			
MQDEC-430RS	9.14 m (30.2 ft)			
MQDEC-450RS	15.2 m (49.9 ft)			
MQDEC-403RR	0.9 m (2.9 ft)	Male Right-Angle / Female Right-Angle		<p>1 = Brown 2 = White 3 = Blue 4 = Black</p>
MQDEC-406RR	1.8 m (5.9 ft)			
MQDEC-412RR	3.6 m (11.8 ft)			
MQDEC-420RR	6.1 m (20 ft)			

4-Pin Threaded M12 Splitter Cordsets—Flat Junction			
Model	Branches (Female)	Trunk (Male)	Pinout
CSB-M1240M1240	No branch	No trunk	<p>Female</p> <p>Male</p> <p>1 = Brown 2 = White 3 = Blue 4 = Black</p>
CSB-M1240M1241	2 × 0.3 m (1 ft)	No trunk	
CSB-M1241M1241		0.31 m (1 ft)	
CSB-M1248M1241		2.44 m (8 ft)	
CSB-M12415M1241		4.57 m (15 ft)	
CSB-M12425M1241		7.60 m (25 ft)	
CSB-UNT425M1241		7.60 m (25 ft) unterminated	
CSB-M1243M1243	2 × 1 m (3.28 ft)	1 m (3.28 ft)	

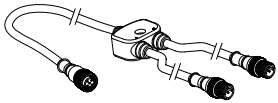
4-Pin Threaded M12 Male to 5-Pin Threaded M12 Female Splitter Cordset		
Model	Branches (Female)	Wiring
S15YB-M124-M124-0.2M	L1, L2 2 × 0.2 m (7.9 in)	

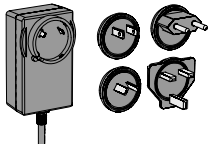
<p>R50-4M125-M125Q-P Molded Junction Block</p> <ul style="list-style-type: none"> • Four integral 5-pin M12 female quick-disconnect connectors • One integral 5-pin M12 male quick-disconnect connector • Parallel wiring 	
<p>R95-8M125-M125Q-P Molded Junction Block</p> <ul style="list-style-type: none"> • Eight integral 5-pin M12 female quick-disconnect connectors • One integral 5-pin M12 male quick-disconnect connector • Parallel wiring 	

5-Pin Threaded M12 Splitter Cordset with Flat Junction—Double Ended				
Model	Trunk (Male)	Branches (Female)	Pinout (Male)	Pinout (Female)
CSB4-M1251M1250	0.3 m (0.98 ft)	Four (no cable)		
			<p>1 = Brown 2 = White 3 = Blue</p>	<p>4 = Black 5 = Gray</p>

<p>CSB-M1251FM1251M</p> <ul style="list-style-type: none"> • 5-pin parallel Y splitter (Male-Male-Female) • For full Pro Editor preview capability • Requires external power supply, sold separately 	
<p>PSD-24-4</p> <ul style="list-style-type: none"> • 90 to 264 V AC 50/60 Hz input • Includes a 1.8 m (6 ft) US style 5-15P input plug • 24 V DC UL Listed Class 2 M12 connector output • 4 A total current 	
<p>PSW-24-2</p> <ul style="list-style-type: none"> • 24 V DC, 2 A Class 2 UL Listed power supply • 100 V AC to 240 V AC 50/60 Hz input • 3.5 m (11.5 ft) PVC cable with M12 quick disconnect • Includes Type A (US, Canada, Japan, Puerto Rico, Taiwan), Type C (Germany, France, South Korea, Netherlands, Poland, Spain, Turkey), Type G (United Kingdom, Ireland, Singapore, Vietnam), and Type I (China, Australia, New Zealand) AC detachable input plugs 	
<p>PSW-24-1</p> <ul style="list-style-type: none"> • 24 V DC, 1 A Class 2 UL Listed power supply • 100 V AC to 240 V AC 50/60 Hz input • 2 m (6.5 ft) PVC cable with M12 quick disconnect • Includes Type A (US, Canada, Japan, Puerto Rico, Taiwan), Type C (Germany, France, South Korea, Netherlands, Poland, Spain, Turkey), Type G (United Kingdom, Ireland, Singapore, Vietnam), and Type I (China, Australia, New Zealand) AC detachable input plugs 	
<p>DXMR90-4K Series Controller IO-Link Master</p> <ul style="list-style-type: none"> • One female M12 D-Code Ethernet connector • Four female M12 connections for IO-Link master connections • One male M12 (Port 0) connection for incoming power and Modbus RS-485, one female M12 connection for daisy chaining Port 0 signals 	
<p>DXMR110-8K Series Controller IO-Link Master</p> <ul style="list-style-type: none"> • Two female M12 D-Code Ethernet connectors for daisy chaining and communication to a higher-level control system • Eight female M12 connections for IO-Link master connections • One male M12 connection for incoming power, one female M12 connection for daisy chaining power 	

Chapter Contents

Document Information 14

Chapter 5 Banner Engineering Corp Limited Warranty

Banner Engineering Corp. warrants its products to be free from defects in material and workmanship for one year following the date of shipment. Banner Engineering Corp. will repair or replace, free of charge, any product of its manufacture which, at the time it is returned to the factory, is found to have been defective during the warranty period. This warranty does not cover damage or liability for misuse, abuse, or the improper application or installation of the Banner product.

THIS LIMITED WARRANTY IS EXCLUSIVE AND IN LIEU OF ALL OTHER WARRANTIES WHETHER EXPRESS OR IMPLIED (INCLUDING, WITHOUT LIMITATION, ANY WARRANTY OF MERCHANTABILITY OR FITNESS FOR A PARTICULAR PURPOSE), AND WHETHER ARISING UNDER COURSE OF PERFORMANCE, COURSE OF DEALING OR TRADE USAGE.

This Warranty is exclusive and limited to repair or, at the discretion of Banner Engineering Corp., replacement. **IN NO EVENT SHALL BANNER ENGINEERING CORP. BE LIABLE TO BUYER OR ANY OTHER PERSON OR ENTITY FOR ANY EXTRA COSTS, EXPENSES, LOSSES, LOSS OF PROFITS, OR ANY INCIDENTAL, CONSEQUENTIAL OR SPECIAL DAMAGES RESULTING FROM ANY PRODUCT DEFECT OR FROM THE USE OR INABILITY TO USE THE PRODUCT, WHETHER ARISING IN CONTRACT OR WARRANTY, STATUTE, TORT, STRICT LIABILITY, NEGLIGENCE, OR OTHERWISE.**

Banner Engineering Corp. reserves the right to change, modify or improve the design of the product without assuming any obligations or liabilities relating to any product previously manufactured by Banner Engineering Corp. Any misuse, abuse, or improper application or installation of this product or use of the product for personal protection applications when the product is identified as not intended for such purposes will void the product warranty. Any modifications to this product without prior express approval by Banner Engineering Corp will void the product warranties. All specifications published in this document are subject to change; Banner reserves the right to modify product specifications or update documentation at any time. Specifications and product information in English supersede that which is provided in any other language. For the most recent version of any documentation, refer to: www.bannerengineering.com.

For patent information, see www.bannerengineering.com/patents.

Document Information

Document title: LC25 LED Controller with IO-Link Instruction Manual

Part number: 234629

Revision: B

Original Instructions

© Banner Engineering Corp. All rights reserved.



234629

 [LinkedIn](#)

 [Twitter](#)

 [Facebook](#)

