

Q2XLP Polarized Retroreflective and Q2XER Opposed Mode Sensor

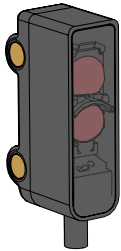

Q2X Features

Miniature sensors featuring extended range and background suppression mode



- Miniature 8 mm (0.31 in) wide sensor for installation in the smallest of spaces
- Exceptional optical performance with long detection range
- Emitter/receiver pair with a large spot for easy alignment
- Polarized retroreflective models for one-sided installation with a retroreflective target
- Emitter/receiver and polarized retroreflective models are ideal for detecting dark and shiny targets
- Bright visible red LED for easy alignment of the sensor
- Many connection types and output configurations are available by model number

WARNING:



- **Do not use this device for personnel protection**
- Using this device for personnel protection could result in serious injury or death.
- This device does not include the self-checking redundant circuitry necessary to allow its use in personnel safety applications. A device failure or malfunction can cause either an energized (on) or de-energized (off) output condition.

Q2X Models

Sensing Mode	Models	Sensing Range	Connection	Output Type
Polarized Retro-reflective, Visible red, 645 nm	Q2XAPLPF-2M	Maximum 3300 mm using BRT-60X40C reflector	2 m (6.5 ft) unterminated 3-wire PVC-jacketed cable	1 PNP Light Operate (LO)
	Q2XANLPF-2M		1 NPN LO	
	Q2XABLPF-Q		150 mm (6 in) PVC-jacketed cable with a 4-pin M8 male quick-disconnect connector	Bipolar LO
Opposed Emitter; Visible red, 645 nm	Q2XNAE-2M	Maximum 3000 mm	2 m (6.5 ft) unterminated 2-wire PVC-jacketed cable	N/A
	Q2XNAE-Q		150 mm (6 in) PVC-jacketed cable with a 4-pin M8 male quick-disconnect connector	N/A
Opposed Receiver	Q2XAPR-2M	Maximum 3000 mm	2 m (6.5 ft) unterminated 3-wire PVC-jacketed cable	1 PNP LO
	Q2XANR-2M		2 m (6.5 ft) unterminated 3-wire PVC-jacketed cable	1 NPN LO
	Q2XABR-Q		150 mm (6 in) PVC-jacketed cable with a 4-pin M8 male quick-disconnect connector	Bipolar LO

- To order Dark Operate (DO) models, replace "AP", "AN", or "AB" with "RP", "RN", or "RB", respectively.
- To order PNP or NPN models with a 150 mm (6 in) PVC cable and a 3-pin M8 male quick disconnect, replace "-2M" with "-Q3".
- To order Bipolar models with a 150 mm (6 in) PVC cable and a 4-pin M12 male quick disconnect, replace "-Q" with "-Q5".

Q2XLP and Q2XER Overview

The Q2X opposed and polarized retroreflective sensors offer excellent sensing performance in a miniature plastic housing which are easily integrated into tight spaces. The brass inserts provide stable mounting points, and the bright indicators provide user feedback of the sensor status.

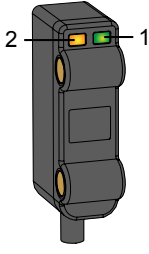
<p><i>Sensor features</i></p> 	<ol style="list-style-type: none"> 1. Green: Power Indicator 2. Yellow: Light Sensed Indicator (Flashes for Marginal Conditions)
---	--

Installation

Mount the Device

1. If a bracket is needed, mount the device onto the bracket.
2. Mount the device (or the device and the bracket) to the machine or equipment at the desired location. Do not tighten the mounting screws at this time.
3. Check the device alignment.
4. Tighten the mounting screws to secure the device (or the device and the bracket) in the aligned position.

Q2XLP and Q2XER Wiring

Cabled wiring diagrams are shown. Quick disconnect wiring diagrams are functionally identical.

CAUTION: Observe proper ESD precautions (grounding) when connecting quick disconnect models.

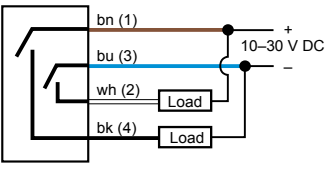
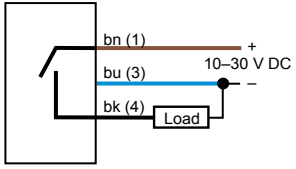
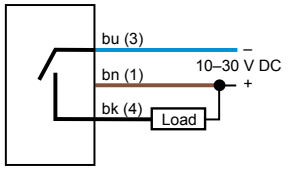
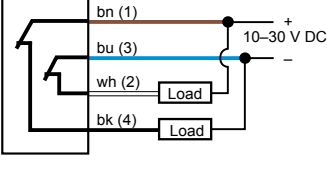
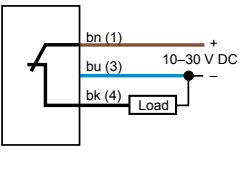
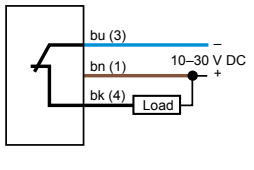
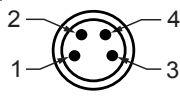
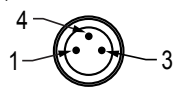
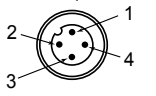
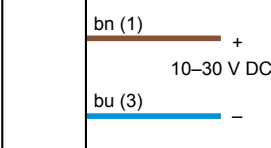
<p>Bipolar Models, Light Operate</p> 	<p>PNP Models, Light Operate</p> 	<p>NPN Models, Light Operate</p> 
<p>Bipolar Models, Dark Operate</p> 	<p>PNP Models, Dark Operate</p> 	<p>NPN Models, Dark Operate</p> 
<p>4-pin M8 Male Quick Disconnect</p> 	<p>3-pin M8 Male Quick Disconnect</p> 	<p>4-pin M12 Male Quick Disconnect</p> 
<p>Key</p> <ul style="list-style-type: none"> 1 = Brown 2 = White 3 = Blue 4 = Black 	<p>Emitter</p> 	

Q2XLP and Q2XER Specifications

Supply Voltage

10 V DC to 30 V DC (10% maximum ripple within specified limits) at less than 16 mA, exclusive of load

Sensing Beam

Visible red LED, 645 nm

Supply Protection Circuitry

Protected against reverse polarity and transient voltages

Output Configuration

Bipolar (1 NPN and 1 PNP) solid-state output or single output (PNP or NPN), light operate (LO) or dark operate (DO), depending on model

Rating: 50 mA total output current

Off-state leakage current: < 10 μ A at 30 V DC

ON-state saturation voltage: < 2 V at 50 mA

Protected against output short-circuit, continuous overload, and false pulse on power-up

Output Response

Polarized Retroreflective models: 600 μ s, OFF to ON and ON to OFF

Opposed Receiver models: 1 ms ON, 0.6 ms OFF

Repeatability

Polarized Retroreflective models: 144 μ s

Opposed Receiver models: 133 μ s

Indicators

Polarized Retroreflective and Opposed Receiver:
2 LED indicators on sensor top:
Green solid: Power on
Amber solid: Light sensed
Amber flashing: Marginal sensing condition

Opposed Emitter:

Green solid: Power on

Construction

PC/ABS housing, acrylic lens cover; PVC cable, acetal adjustment potentiometer

Environmental Rating

IP67

Connections

2 m (6.5 ft) unterminated 2-wire PVC-jacketed cable, 2 m (6.5 ft) unterminated 3-wire PVC-jacketed cable, 150 mm (6 in) PVC-jacketed cable with a 3-pin M8 male quick-disconnect connector, 150 mm (6 in) PVC-jacketed cable with a 4-pin M8 male quick-disconnect connector, or 150 mm (6 in) PVC-jacketed cable with a 4-pin M12 male quick-disconnect connector, depending on model.

Operating Conditions

95% at +50 °C maximum relative humidity (non-condensing)

Temperature: -25 °C to +50 °C (-13 °F to +122 °F)

Certifications



Banner Engineering BV
Park Lane, Culliganlaan 2F bus 3
1831 Diegem, BELGIUM



Turck Banner LTD Blenheim House
Blenheim Court
Wickford, Essex SS11 8YT
GREAT BRITAIN



Industrial
Control
Equipment
3TJJ

Required Overcurrent Protection



WARNING: Electrical connections must be made by qualified personnel in accordance with local and national electrical codes and regulations.

Overcurrent protection is required to be provided by end product application per the supplied table.

Overcurrent protection may be provided with external fusing or via Current Limiting, Class 2 Power Supply.

Supply wiring leads < 24 AWG shall not be spliced.

For additional product support, go to www.bannerengineering.com.

Supply Wiring (AWG)	Required Overcurrent Protection (A)	Supply Wiring (AWG)	Required Overcurrent Protection (A)
20	5.0	26	1.0
22	3.0	28	0.8
24	1.0	30	0.5

FCC Part 15 Class B

This equipment has been tested and found to comply with the limits for a Class B digital device, pursuant to part 15 of the FCC Rules. These limits are designed to provide reasonable protection against harmful interference in a residential installation. This equipment generates, uses and can radiate radio frequency energy and, if not installed and used in accordance with the instructions, may cause harmful interference to radio communications. However, there is no guarantee that interference will not occur in a particular installation. If this equipment does cause harmful interference to radio or television reception, which can be determined by turning the equipment off and on, the user is encouraged to try to correct the interference by one or more of the following measures:

- Reorient or relocate the receiving antenna.
- Increase the separation between the equipment and receiver.
- Connect the equipment into an outlet on a circuit different from that to which the receiver is connected.
- Consult the dealer or an experienced radio/TV technician for help.

Industry Canada ICES-003(B)

This device complies with CAN ICES-3 (B)/NMB-3(B). Operation is subject to the following two conditions: 1) This device may not cause harmful interference; and 2) This device must accept any interference received, including interference that may cause undesired operation.

Cet appareil est conforme à la norme NMB-3(B). Le fonctionnement est soumis aux deux conditions suivantes : (1) ce dispositif ne peut pas occasionner d'interférences, et (2) il doit tolérer toute interférence, y compris celles susceptibles de provoquer un fonctionnement non souhaité du dispositif.

Q2XLP and Q2XER Dimensions

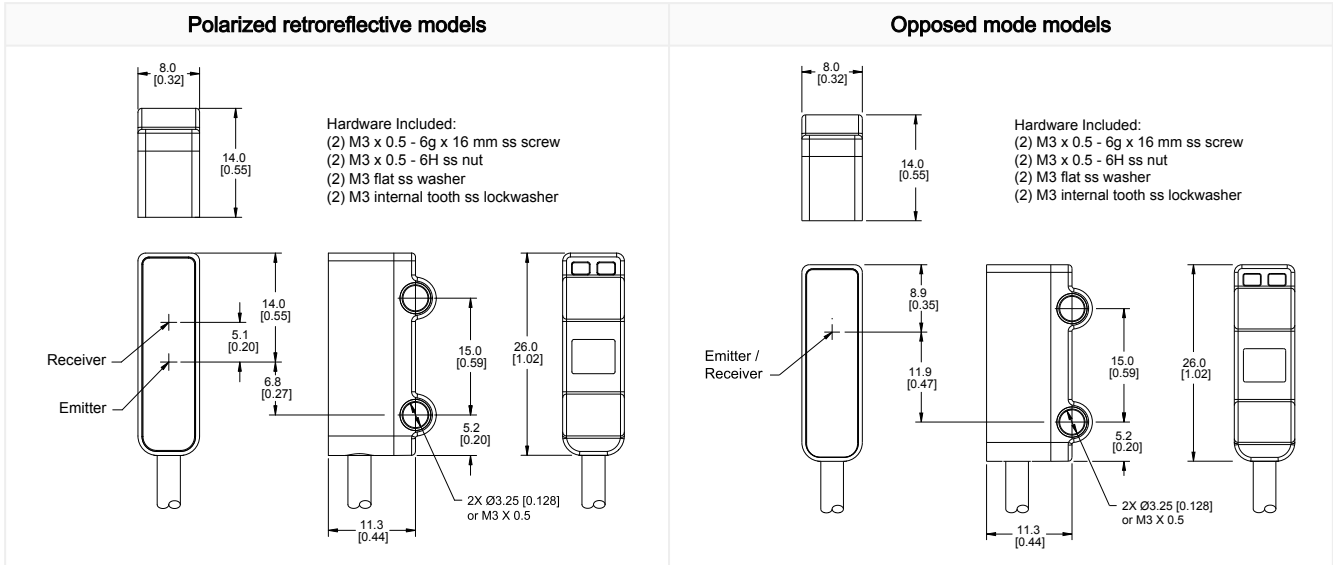

All measurements are listed in millimeters [inches], unless noted otherwise. Maximum torque 0.9 Nm (8 in-lbf).

Q2XLP and Q2X ER Performance Curves

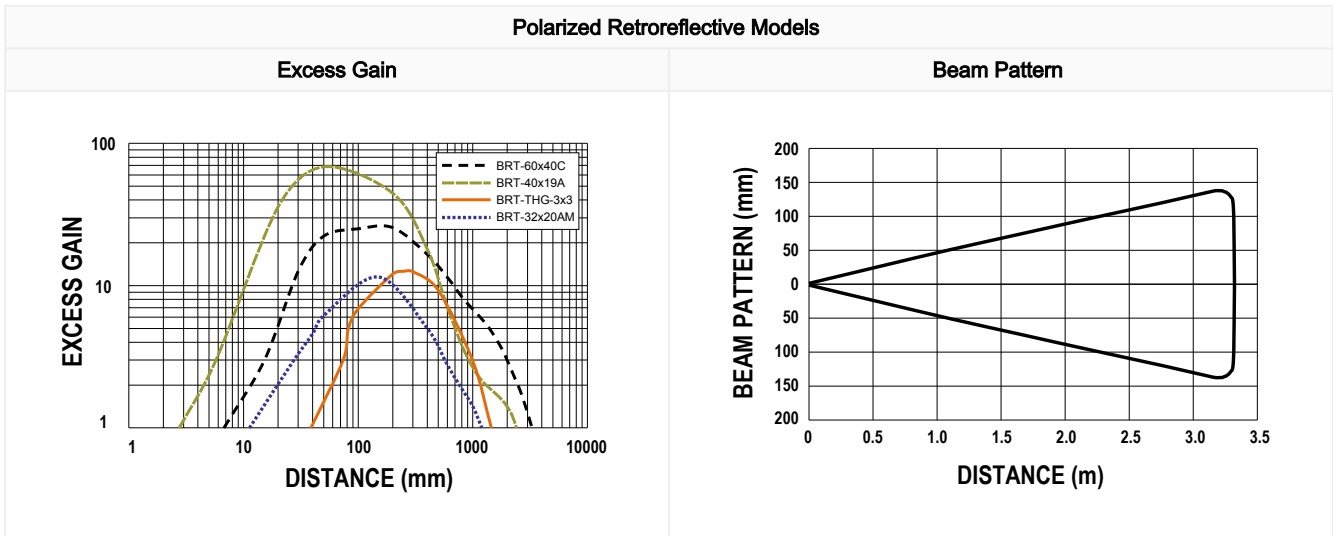

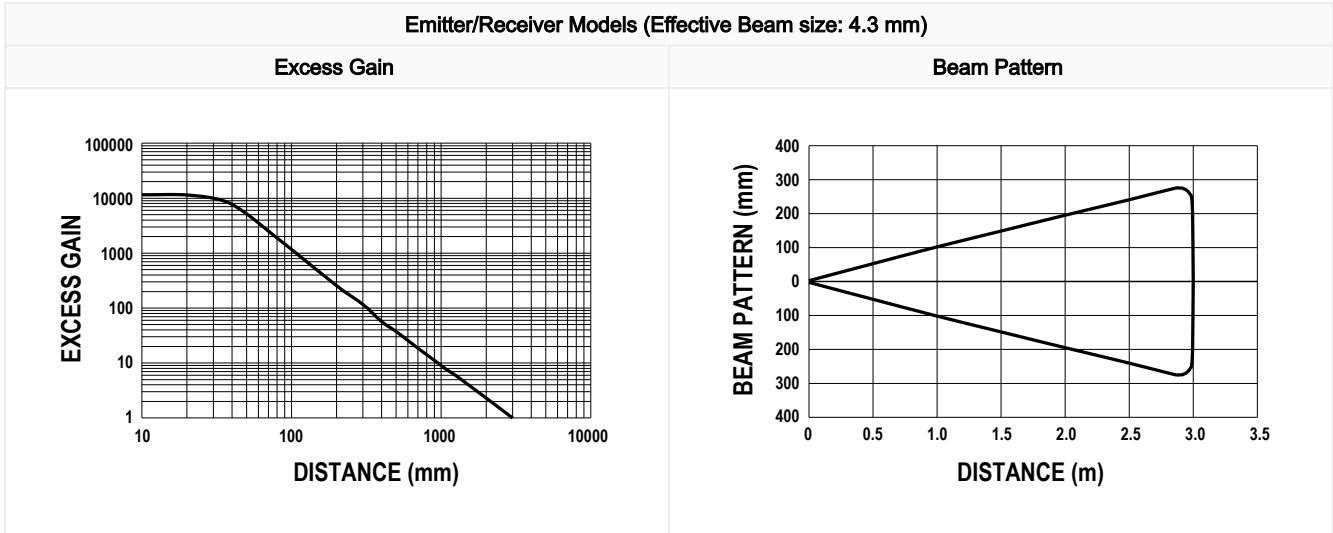

Accessories

Cordsets

3-pin Threaded M8 Cordsets—Single Ended				
Model	Length	Style	Dimensions	Pinout (Female)
PKG3M-2	2.035 m (6.68 ft)	Straight		<p>1 = Brown 3 = Blue 4 = Black</p>
PKG3M-5	5.035 m (16.51 ft)			
PKG3M-7	7.035 m (23.08 ft)			
PKG3M-9	9.035 m (29.64 ft)			
PKG3M-10	10.035 m (32.92 ft)			
PKW3M-2	2 m (6.56 ft)	Right-Angle		
PKW3M-5	5 m (16.40 ft)			
PKW3M-9	9 m (29.53 ft)			

4-Pin Threaded M8 Cordsets—Single Ended				
Model	Length	Style	Dimensions	Pinout (Female)
PKG4M-2	2.04 m (6.68 ft)	Straight		<p>1 = Brown 2 = White 3 = Blue 4 = Black</p>
PKG4M-5	5 m (16.4 ft)			
PKG4M-9	9.04 m (29.6 ft)			

Continued on page 6

Continued from page 5

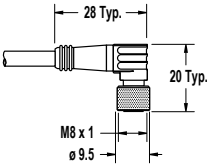
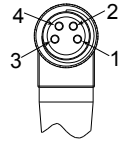
4-Pin Threaded M8 Cordsets—Single Ended				
Model	Length	Style	Dimensions	Pinout (Female)
PKW4M-2	2 m (6.56 ft)	Right Angle		
PKW4M-5	5 m (16.4 ft)			
PKW4M-9	9 m (29.5 ft)			

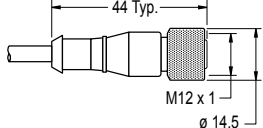
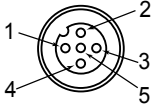
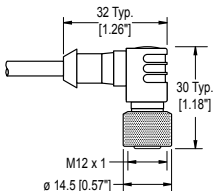
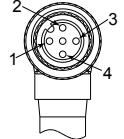
4-Pin Threaded M12 Cordsets—Single Ended				
Model	Length	Style	Dimensions	Pinout (Female)
MQDC-406	2 m (6.56 ft)	Straight		
MQDC-415	5 m (16.4 ft)			
MQDC-430	9 m (29.5 ft)			
MQDC-450	15 m (49.2 ft)	Right-Angle		
MQDC-406RA	2 m (6.56 ft)			
MQDC-415RA	5 m (16.4 ft)			
MQDC-430RA	9 m (29.5 ft)			
MQDC-450RA	15 m (49.2 ft)			<p>1 = Brown 2 = White 3 = Blue 4 = Black 5 = Unused</p>

Brackets

All measurements are listed in millimeters, unless noted otherwise.

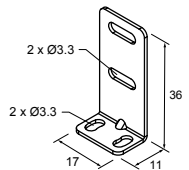
<p>SMBQ2XA</p> <ul style="list-style-type: none"> Vertical L-shaped bracket 20-ga stainless steel 	
--	---

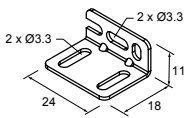
<p>SMBQ2XB</p> <ul style="list-style-type: none"> Rear L-shaped bracket 20-ga stainless steel 	
--	---

Reflectors

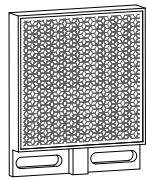
<p>BRT-2X2</p> <ul style="list-style-type: none"> Square, acrylic target Reflectivity factor: 1.0 Max. temperature: +50 °C (+122 °F) Optional brackets are available Approximate size: 51 mm × 51 mm 	
--	---

BRT-84X84A

- Square, acrylic target
- Reflectivity Factor: 2.0
- Temperature:
- Approximate size: 84 mm × 84 mm

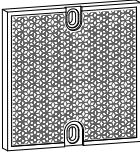

BRT-40X19A

- Rectangular, acrylic target
- Reflectivity Factor: 1.3
- Temperature:
- Approximate size: 19 mm × 60 mm overall; 19 mm × 40 mm reflector

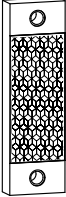

BRT-60X40C

- Rectangular, acrylic target
- Reflectivity Factor: 1.4
- Temperature:
- Optional brackets are available
- Approximate size: 40 mm × 60 mm

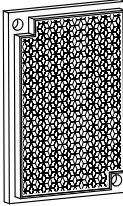

BRT-60X40IP69K

- Rectangular, acrylic target (color is amber)
- Reflectivity Factor: 0.7
- Temperature: -20 °C to +140 °C (-4 °F to +284 °F)
- Chemically resistant
- IP69K washdown rated
- Optional brackets are available
- Approximate size: 40 mm × 60 mm

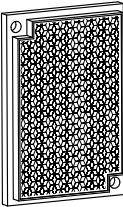

BRT-60X40AF

- Rectangular, acrylic target
- Reflectivity Factor: 1.4
- Temperature:
- Anti-fogging coating for use around steam
- Optional brackets are available
- Approximate size: 40 mm × 60 mm

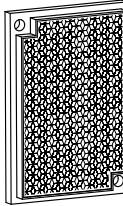

BRT-84

- Round, acrylic target
- Reflectivity Factor: 1.4
- Temperature:
- Optional brackets are available
- Size: 84 mm diameter
- Mounting Hole: 4.5 mm diameter



Retroreflective Tape

Model	Reflectivity Factor	Maximum Temperature	Size
BRT-THG-2-100	0.7	+60 °C (+140 °F)	50 mm (2 in) wide, 2.5 m (100 in) long

Aperture Kits

Model	Description	Pieces
APQ2X-1	Circular aperture, 1.0 mm (0.04 in) diameter	2
APQ2X-1.5	Circular aperture, 1.5 mm (0.06 in) diameter	2
APQ2X-2	Circular aperture, 2.0 mm (0.08 in) diameter	2
APQ2X-VH	Cross-talk avoidance polarizing filter	4

Banner Engineering Corp Limited Warranty

Banner Engineering Corp. warrants its products to be free from defects in material and workmanship for one year following the date of shipment. Banner Engineering Corp. will repair or replace, free of charge, any product of its manufacture which, at the time it is returned to the factory, is found to have been defective during the warranty period. This warranty does not cover damage or liability for misuse, abuse, or the improper application or installation of the Banner product.

THIS LIMITED WARRANTY IS EXCLUSIVE AND IN LIEU OF ALL OTHER WARRANTIES WHETHER EXPRESS OR IMPLIED (INCLUDING, WITHOUT LIMITATION, ANY WARRANTY OF MERCHANTABILITY OR FITNESS FOR A PARTICULAR PURPOSE), AND WHETHER ARISING UNDER COURSE OF PERFORMANCE, COURSE OF DEALING OR TRADE USAGE.

This Warranty is exclusive and limited to repair or, at the discretion of Banner Engineering Corp., replacement. **IN NO EVENT SHALL BANNER ENGINEERING CORP. BE LIABLE TO BUYER OR ANY OTHER PERSON OR ENTITY FOR ANY EXTRA COSTS, EXPENSES, LOSSES, LOSS OF PROFITS, OR ANY INCIDENTAL, CONSEQUENTIAL OR SPECIAL DAMAGES RESULTING FROM ANY PRODUCT DEFECT OR FROM THE USE OR INABILITY TO USE THE PRODUCT, WHETHER ARISING IN CONTRACT OR WARRANTY, STATUTE, TORT, STRICT LIABILITY, NEGLIGENCE, OR OTHERWISE.**

Banner Engineering Corp. reserves the right to change, modify or improve the design of the product without assuming any obligations or liabilities relating to any product previously manufactured by Banner Engineering Corp. Any misuse, abuse, or improper application or installation of this product or use of the product for personal protection applications when the product is identified as not intended for such purposes will void the product warranty. Any modifications to this product without prior express approval by Banner Engineering Corp will void the product warranties. All specifications published in this document are subject to change; Banner reserves the right to modify product specifications or update documentation at any time. Specifications and product information in English supersede that which is provided in any other language. For the most recent version of any documentation, refer to: www.bannerengineering.com.

For patent information, see www.bannerengineering.com/patents.

Document title: Q2X Polarized Retroreflective and Opposed Mode Sensors
Part number: 226597
Revision: C
Original Instructions
© Banner Engineering Corp. All rights reserved.

