

Features

- Compact bimodal to Modbus® device converter that connects discrete inputs and outputs the value
- Outputs a discrete value as an input to a defined Modbus register
- Discrete input/output can be independently configured as NPN or PNP
- Rugged overmolded design meets IP65, IP67, and IP68
- Connects directly to a sensor or anywhere in-line for ease of use



Models

Housing	Function	-	Female Port	-	Male Port	Connector
S15	C	-	B22	-	M	Q
	C=Converter		B22=Bimodal, two inputs, two outputs		M=Modbus	Q=Integral M12 quick disconnect

Configuration Instructions

Sensor Configuration Software

The Sensor Configuration Software offers an easy way to manage converter Modbus settings, retrieve data, and visually show converter data. The Sensor Configuration Software runs on any Windows machine and uses an adapter cable (BWA-UCT-900, p/n 19970) to connect the converter to the computer.

Download the most recent version of the Sensor Configuration Software from the Banner Engineering website: https://info.bannerengineering.com/cs/groups/public/documents/software/b_3128586.exe.

Modbus Configuration

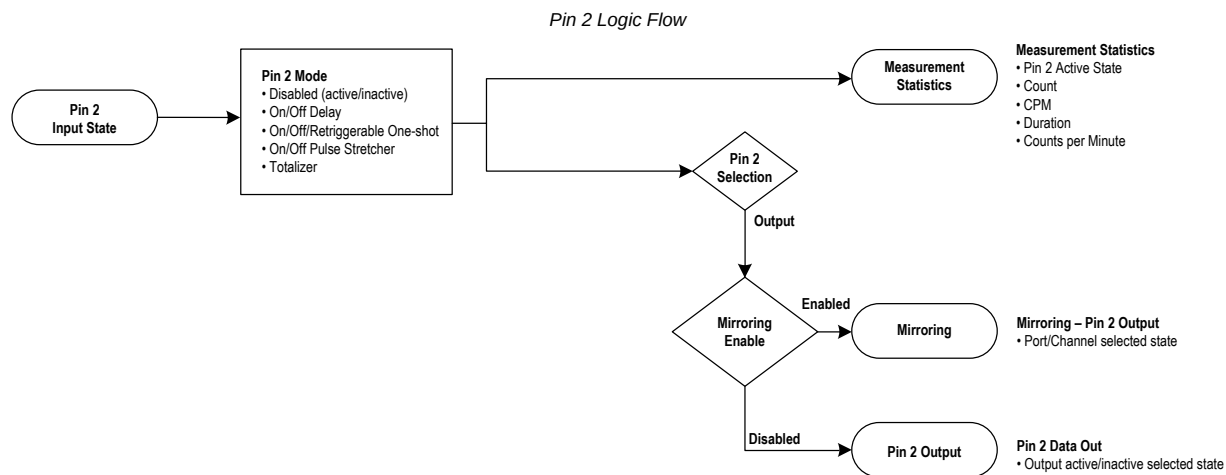

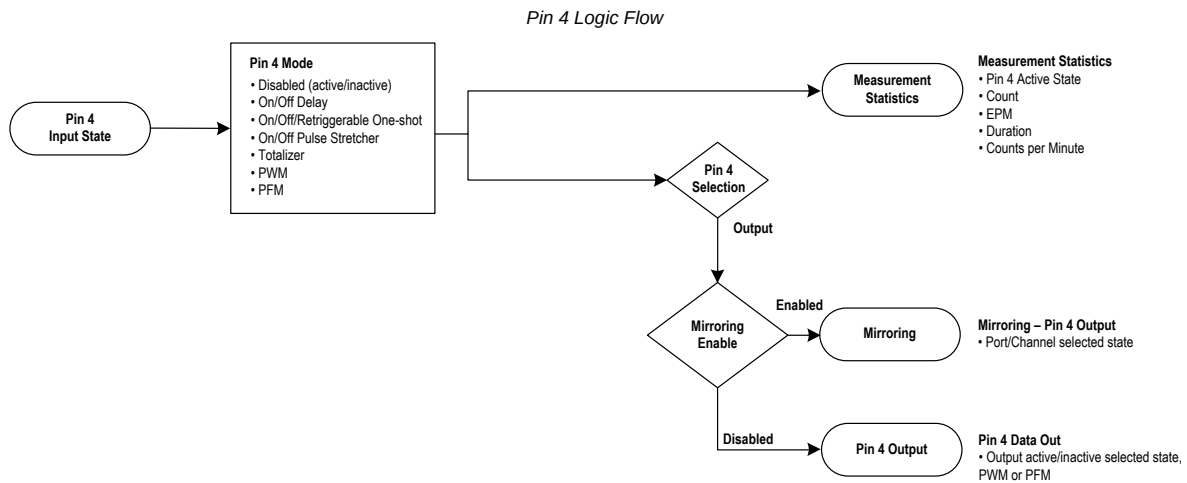

Measurement Reads

Modbus Register Address	Description	I/O Range	Comments	Default	Access	Notes
40001	Pin 4 Active State	0..1	0 = Inactive, 1 = Active	—	RO	—
40002	Pin 2 Active State	0..1	0 = Inactive, 1 = Active	—	RO	—
40003	Pin 4 Count Higher (H)	0..65535	Pin 4 Count Value Upper	—	RO	Upper 16 of 32 bits = Running count of the received input pulses
40004	Pin 4 Count Lower (L)	0..65535	Pin 4 Count Value Lower	—	RO	Lower 16 of 32 bits = Running count of the received input pulses
40005	Pin 4 Duration H	0..65535	Pin 4 Duration Value Upper	—	RO	Upper 16 of 32 bits = Duration of the last input pulse in μ s with 50 μ s granularity
40006	Pin 4 Duration L	0..65535	Pin 4 Duration Value Lower	—	RO	Lower 16 of 32 bits = Duration of the last input pulse in μ s with 50 μ s granularity
40007	Pin 4 Events Per Minute H	0..65535	Pin 4 Events Per Minute Value Upper	—	RO	Upper 16 of 32 bits = Instantaneous rate counter in the units of events per minute Range 1 to 300,000 Max Counter Input Frequency: 5 kHz
40008	Pin 4 Events Per Minute L	0..65535	Pin 4 Events Per Minute Value Lower	—	RO	Lower 16 of 32 bits = Instantaneous rate counter in the units of events per minute Range 1 to 300,000 Max Counter Input Frequency: 5 kHz
40009	Pin 4 Totalizer Count H	0..65535	Pin 4 Totalizer Count Upper	—	RO	Upper 16 of 32 bits = Totalizer Count
40010	Pin 4 Totalizer Count L	0..65535	Pin 4 Totalizer Count Lower	—	RO	Lower 16 of 32 bits = Totalizer Count
40011	Pin 2 Count H	0..65535	Pin 2 Count Value Upper	—	RO	Upper 16 of 32 bits = Running count of the received input pulses
40012	Pin 2 Count L	0..65535	Pin 2 Count Value Lower	—	RO	Lower 16 of 32 bits = Running count of the received input pulses
40013	Pin 2 Duration H	0..65535	Pin 2 Duration Value Upper	—	RO	Upper 16 of 32 bits = Duration of the last input pulse in μ s with 50 μ s granularity

Continued on page 3

Continued from page 2

Modbus Register Address	Description	I/O Range	Comments	Default	Access	Notes
40014	Pin 2 Duration L	0..65535	Pin 2 Duration Value Lower	—	RO	Lower 16 of 32 bits = Duration of the last input pulse in μ s with 50 μ s granularity
40015	Pin 2 Events Per Minute H	0..65535	Pin 2 Events Per Minute Value Upper	—	RO	Upper 16 of 32 bits = Instantaneous rate counter in the units of events per minute Range: 1 to 300,000 Max Counter Input Frequency: 5 kHz
40016	Pin 2 Events Per Minute L	0..65535	Pin 2 Events Per Minute Value Lower	—	RO	Lower 16 of 32 bits = Instantaneous rate counter in the units of events per minute Range: 1 to 300,000 Max Counter Input Frequency: 5 kHz
40017	Pin 2 Totalizer Count H	0..65535	Pin 2 Totalizer Count Upper	—	RO	Upper 16 of 32 bits = Totalizer Count
40018	Pin 2 Totalizer Count L	0..65535	Pin 2 Totalizer Count Lower	—	RO	Lower 16 of 32 bits = Totalizer Count
40019	Pin 4 Counts per Minute H	0..65535	Pin 4 Counts per Minute Value Upper	—	RO	Upper 16 of 32 bits = Rolling count per minute average Range: 1 to 300,000 Max Counter Input Frequency: 5 kHz
40020	Pin 4 Counts per Minute L	0..65535	Pin 4 Counts per Minute Value Lower	—	RO	Lower 16 of 32 bits = Rolling count per minute average Range: 1 to 300,000 Max Counter Input Frequency: 5 kHz
40021	Pin 2 Counts per Minute H	0..65535	Pin 2 Counts per Minute Value Upper	—	RO	Upper 16 of 32 bits = Rolling count per minute average Range: 1 to 300,000 Max Counter Input Frequency: 5 kHz
40022	Pin 2 Counts per Minute L	0..65535	Pin 2 Counts per Minute Value Lower	—	RO	Lower 16 of 32 bits = Rolling count per minute average Range: 1 to 300,000 Max Counter Input Frequency: 5 kHz

Metric Count Presets

Modbus Register Address	Description	I/O Range	Comments	Default	Access
40100	Pin 4 Count H	0..65535	Pin 4 Count Value Uppper	—	RW
40101	Pin 4 Count L	0..65535	Pin 4 Count Value Lower	—	RW
40102	Pin 2 Count H	0..65535	Pin 2 Count Value Upper	—	RW
40103	Pin 2 Count L	0..65535	Pin 2 Count Value Lower	—	RW

Pin 4 Port Configuration

Modbus Register Address	Description	I/O Range	Comments	Default	Access	Notes
40200	Pin 4 IO Selection	0..5	0 = NPN input 1 = PNP input 2 = NPN output with pull up 3 = PNP output with pull down 4 = NPN output push/pull 5 = PNP output push/pull	1	RW	—

Continued on page 4

Continued from page 3

Modbus Register Address	Description	I/O Range	Comments	Default	Access	Notes
40201	Pin 4 Mode	0..8	0 = Disabled 1 = On Off Delay 2 = On One-shot 3 = Off One-shot 4 = On Pulse-stretcher 5 = Off Pulse-stretcher 6 = Totalizer 7 = Retriggerable On One-shot 8 = Retriggerable Off One-shot 9 = PWM 10 = PFM	0	RW	—
40202	Pin 4 Delay Timer 1 Upper	0..65535	Pin 4 On Delay, One-shot, Pulse-stretcher time, Totalizer Count	0	RW	Upper 16 of 32 Bits: Mode 1, 2, 3, 4, 5 = Milliseconds Mode 6 = Count Mode 7 and 8 = Don't Care
40203	Pin 4 Delay Timer 1 Lower	0..65535	Pin 4 On Delay, One-shot, Pulse-stretcher time, Totalizer Count	0	RW	Lower 16 of 32 Bits: Mode 1, 2, 3, 4, 5 = Milliseconds Mode 6 = Count Mode 7 and 8 = Don't Care
40204	Pin 4 Delay Timer 2 Upper	0..65535	Pin 4 Off Delay or Totalizer time	0	RW	Upper 16 of 32 Bits: Mode 1, 2, 3, 4, 5 = Milliseconds Mode 6 = Count Mode 7 and 8 = Don't Care
40205	Pin 4 Delay Timer 2 Lower	0..65535	Pin 4 Off Delay or Totalizer time	0	RW	Lower 16 of 32 Bits: Mode 1, 2, 3, 4, 5 = Milliseconds Mode 6 = Count Mode 7 and 8 = Don't Care
40206	Pin 4 Mirroring Enable	0..1	0 = Disabled, 1 = Enabled	0	RW	—
40207	Pin 4 Mirroring Selection	0..1	0 = Pin 4, 1 = Pin 2	0	RW	—
40208	Pin 4 Mirroring Inversion	0..1	0 = Not Inverted, 1 = Inverted	0	RW	—
40209	Pin 4 PWM Base Frequency	50..50000	PWM base frequency	500	RW	PWM base frequency = 50 (Hz)..50K(Hz)
40210	Pin 4 PWM Percentage	0..100	PWM percentage	100	RW	PWM % = 0..100 If PWM % > 100, = 100
40211	Pin 4 PFM Frequency	50..50000	PFM frequency	50000	RW	PFM 50 (Hz)..50K (Hz)

Pin 2 Port Configuration

Modbus Register Address	Description	I/O Range	Comments	Default	Access	Notes
40300	Pin 2 IO Selection	0..5	0 = NPN input 1 = PNP input 2 = NPN output with pull up 3 = PNP output with pull down 4 = NPN output push/pull 5 = PNP output push/pull	0	RW	—
40301	Pin 2 Mode	0..6	0 = Disabled 1 = On Off Delay 2 = On One-shot 3 = Off One-shot 4 = On Pulse-stretcher 5 = Off Pulse-stretcher 6 = Totalizer 7 = Retriggerable On One-shot 8 = Retriggerable Off One-shot	0	RW	—
40302	Pin 2 Delay Timer 1 Upper	0..65535	Pin 2 On Delay, One-shot, Pulse-stretcher time, or Totalizer Count	0	RW	Upper 16 of 32 Bits: Mode 1, 2, 3, 4, 5 = Milliseconds Mode 6 = Count
40303	Pin 2 Delay Timer 1 Lower	0..65535	Pin 2 On Delay, One-shot, Pulse-stretcher time, or Totalizer Count	0	RW	Lower 16 of 32 Bits: Mode 1, 2, 3, 4, 5 = Milliseconds Mode 6 = Count
40304	Pin 2 Delay Timer 2 Upper	0..65535	Pin 2 Off Delay or Totalizer time	0	RW	Upper 16 of 32 Bits: Mode 1, 2, 3, 4, 5 = Milliseconds Mode 6 = Count
40305	Pin 2 Delay Timer 2 Lower	0..65535	Pin 2 Off Delay or Totalizer time	0	RW	Lower 16 of 32 Bits: Mode 1, 2, 3, 4, 5 = Milliseconds Mode 6 = Count
40306	Mirroring Enable	0..1	0 = Disabled, 1 = Enabled	0	RW	—
40307	Pin 2 Mirroring Selection	0..1	0 = Pin 4, 1 = Pin 2	0	RW	—

Continued on page 5

Continued from page 4

Modbus Register Address	Description	I/O Range	Comments	Default	Access	Notes
40308	Pin 2 Mirroring Inversion	0..1	0 = Not Inverted, 1 = Inverted	0	RW	—

Active Configurations

Modbus Register Address	Description	I/O Range	Comments	Default	Access	Notes
40400	Pin 4 Output	0..1	0 = Inactive, 1 = Active	0	RW	If mirroring is disabled and IO selection is output, then Output is set to inactive/active
40401	Pin 2 Output	0..1	0 = Inactive, 1 = Active	0	RW	
40402	Counts per Minute Mode	0..2	0 = Slow, 1 = Medium, 2 = Fast	1	RW	Amount of time or speed used to fill the rolling average buffer

Discrete Host Out Mirroring (Gray - Male)

Modbus Register Address	Description	I/O Range	Comments	Default	Access
40500	Host Mirroring Enable	0..1	0 = Disable, 1 = Enable	0	RW
40501	Host Mirror Channel Selection	0..1	0 = Pin 4, 1 = Pin 2	0	RW
40502	Host Mirroring Inversion	0..1	0 = Not Inverted, 1 = Inverted	0	RW
40503	Host Mirroring Polarity	0..1	0 = NPN Output, 1 = PNP Output	1	RW
40504	Host Mirroring Output Type	0..2	0 = Output with Internal Pull Up/Down 1 = Output Open Collector 2 = Output Push Pull	0	RW

Modbus Configuration

Modbus Register Address	Description	I/O Range	Comments	Default	Access
40601	Baud Rate	0 = 9.6k 1 = 19.2k 2 = 38.4k	0 = 9600 1 = 19200 2 = 38400	1	RW
40602	Parity	0 = None 1 = Odd 2 = Even	0 = None 1 = Odd 2 = Even	0	RW
40603	Address	1-254	-	1	RW
40604	Reserved (cannot be read or written)	None	-	-	RW
40605	Restore Factory Configuration	0 = No Operation, 1 = Restore	-	-	WO

Device Information

Modbus Register Address ⁽¹⁾	Description	I/O Range	Comments	Default	Access	Notes
40606-40615	Banner Name	0..65535	-	Banner Engineering	RO	(9 words/18 characters)
40616-40631	Product Name	0..65535	-	S15C-B22-MQ	RO	(16 words/32 characters)
40632	Item H	0..65535	812324 split into two 16-bit registers	12	RO	Banner Item Number
40633	Item L	0..65535		25892	RO	-
40634	Serial Number H	0..65535	-	-	RO	Serial Number is split into four 16-bit registers
40635	Serial Number	0..65535	-	-	RO	
40636	Serial Number	0..65535	-	-	RO	
40637	Serial Number L	0..65535	-	-	RO	
40644-40659	User Define Tag	0..65535	User writable space	More Sensors. More Solutions.	RW	(16 words/32 characters)

⁽¹⁾ Registers are big endian.

Wiring Diagrams

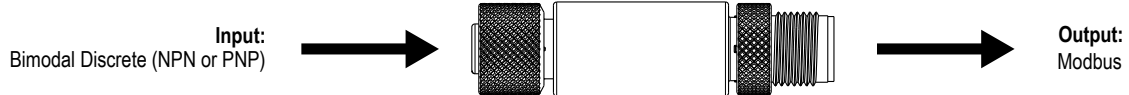

Male	Female	Pin	Wire Color
		1	Brown
		2	White
		3	Blue
		4	Black
		5 (male only)	Gray (male only)

Connecting Devices with Discrete Inputs/Outputs

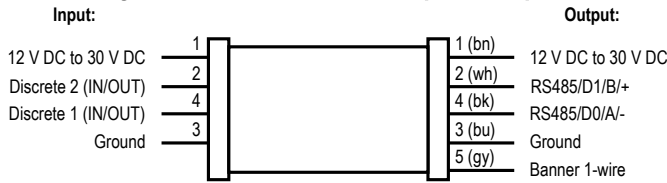

Status Indicators

Power LED Indicator (Green)

- Solid Green = Power On
- Off = Power Off

Modbus Communication LED Indicator (Amber)

- Flashing Amber (4 Hz) = Modbus communications are active
- Solid Amber for 2 Seconds to Off = Modbus communications are lost after connection
- Solid Amber for 2 Seconds to Flashing Amber (4 Hz) = Modbus communications momentarily lost, but communication reestablished
- Solid Amber = Modbus communications are intermittent, or communications error occurs more frequently than once every 2 seconds
- Off = Modbus communications are not present

Specifications

Supply Voltage

12 V DC to 30 V DC at 50 mA maximum

Power Pass-Through Current

1 A maximum

Discrete Output Load Rating

50 mA

Supply Protection Circuitry

Protected against reverse polarity and transient voltages

Leakage Current Immunity

400 μ A

Discrete Output Ratings

OFF-state leakage current:

NPN: 300 μ A
PNP: 10 μ A

ON-state saturation voltage:

NPN: 2 V at 50 mA
PNP: 2 V at 50 mA

Indicators

Green: Power
Amber: Modbus communications

Connections

Integral male/female 4-pin M12 quick-disconnect connector

Construction

Coupling Material: Nickel-plated brass
Connector Body: PVC translucent black

Vibration and Mechanical Shock

Meets IEC 60068-2-6 requirements (Vibration: 10 Hz to 55 Hz, 0.5 mm amplitude, 5 minutes sweep, 30 minutes dwell)

Meets IEC 60068-2-27 requirements (Shock: 15G 11 ms duration, half sine wave)

Environmental Rating

IP65, IP67, IP68
NEMA/UL Type 1

Operating Conditions

Temperature: -40 °C to +70 °C (-40 °F to +158 °F)

90% at +70 °C maximum relative humidity (non-condensing)

Storage Temperature: -40 °C to +80 °C (-40 °F to +176 °F)

Required Overcurrent Protection



WARNING: Electrical connections must be made by qualified personnel in accordance with local and national electrical codes and regulations.

Overcurrent protection is required to be provided by end product application per the supplied table.
 Overcurrent protection may be provided with external fusing or via Current Limiting, Class 2 Power Supply.
 Supply wiring leads < 24 AWG shall not be spliced.
 For additional product support, go to www.bannerengineering.com.

Supply Wiring (AWG)	Required Overcurrent Protection (A)	Supply Wiring (AWG)	Required Overcurrent Protection (A)
20	5.0	26	1.0

Continued on page 8

Continued from page 6

Supply Wiring (AWG)	Required Overcurrent Protection (A)	Supply Wiring (AWG)	Required Overcurrent Protection (A)
22	3.0	28	0.8
24	1.0	30	0.5

Certifications



Banner Engineering BV
 Park Lane, Culliganlaan 2F bus 3
 1831 Diegem, BELGIUM



Turck Banner LTD Blenheim House
 Blenheim Court
 Wickford, Essex SS11 8YT
 GREAT BRITAIN



PROGRAMMABLE
 CONTROLLER
 E316212

FCC Part 15 Class B for Unintentional Radiators

(Part 15.105(b)) This equipment has been tested and found to comply with the limits for a Class B digital device, pursuant to part 15 of the FCC Rules. These limits are designed to provide reasonable protection against harmful interference in a residential installation. This equipment generates, uses, and can radiate radio frequency energy and, if not installed and used in accordance with the instructions, may cause harmful interference to radio communications. However, there is no guarantee that interference will not occur in a particular installation. If this equipment does cause harmful interference to radio or television reception, which can be determined by turning the equipment off and on, the user is encouraged to try to correct the interference by one or more of the following measures:

- Reorient or relocate the receiving antenna.
- Increase the separation between the equipment and receiver.
- Connect the equipment into an outlet on a circuit different from that to which the receiver is connected.
- Consult the dealer or an experienced radio/TV technician for help.

(Part 15.21) Any changes or modifications not expressly approved by the party responsible for compliance could void the user's authority to operate this equipment.

Industry Canada ICES-003(B)

This device complies with CAN ICES-3 (B)/NMB-3(B). Operation is subject to the following two conditions: 1) This device may not cause harmful interference; and 2) This device must accept any interference received, including interference that may cause undesired operation.

Cet appareil est conforme à la norme NMB-3(B). Le fonctionnement est soumis aux deux conditions suivantes : (1) ce dispositif ne peut pas occasionner d'interférences, et (2) il doit tolérer toute interférence, y compris celles susceptibles de provoquer un fonctionnement non souhaité du dispositif.

Dimensions

All measurements are listed in millimeters [inches], unless noted otherwise.

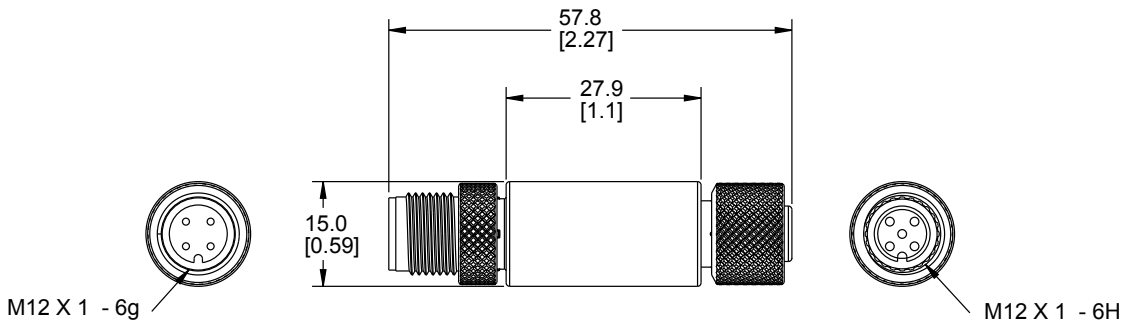

Accessories

Cordsets

4-Pin Threaded M12 Cordsets—Double Ended				
Model	Length	Style	Dimensions	Pinout
MQDEC-401SS	0.31 m (1 ft)	Male Straight/Female Straight		Female
MQDEC-403SS	0.91 m (2.99 ft)			
MQDEC-406SS	1.83 m (6 ft)			
MQDEC-412SS	3.66 m (12 ft)			<p>1 = Brown 2 = White 3 = Blue 4 = Black</p>
MQDEC-415SS	4.58 m (15 ft)			
MQDEC-420SS	6.10 m (20 ft)			
MQDEC-430SS	9.14 m (30.2 ft)			
MQDEC-450SS	15.2 m (49.9 ft)			

Banner Engineering Corp Limited Warranty

Banner Engineering Corp. warrants its products to be free from defects in material and workmanship for one year following the date of shipment. Banner Engineering Corp. will repair or replace, free of charge, any product of its manufacture which, at the time it is returned to the factory, is found to have been defective during the warranty period. This warranty does not cover damage or liability for misuse, abuse, or the improper application or installation of the Banner product.

THIS LIMITED WARRANTY IS EXCLUSIVE AND IN LIEU OF ALL OTHER WARRANTIES WHETHER EXPRESS OR IMPLIED (INCLUDING, WITHOUT LIMITATION, ANY WARRANTY OF MERCHANTABILITY OR FITNESS FOR A PARTICULAR PURPOSE), AND WHETHER ARISING UNDER COURSE OF PERFORMANCE, COURSE OF DEALING OR TRADE USAGE.

This Warranty is exclusive and limited to repair or, at the discretion of Banner Engineering Corp., replacement. **IN NO EVENT SHALL BANNER ENGINEERING CORP. BE LIABLE TO BUYER OR ANY OTHER PERSON OR ENTITY FOR ANY EXTRA COSTS, EXPENSES, LOSSES, LOSS OF PROFITS, OR ANY INCIDENTAL, CONSEQUENTIAL OR SPECIAL DAMAGES RESULTING FROM ANY PRODUCT DEFECT OR FROM THE USE OR INABILITY TO USE THE PRODUCT, WHETHER ARISING IN CONTRACT OR WARRANTY, STATUTE, TORT, STRICT LIABILITY, NEGLIGENCE, OR OTHERWISE.**

Banner Engineering Corp. reserves the right to change, modify or improve the design of the product without assuming any obligations or liabilities relating to any product previously manufactured by Banner Engineering Corp. Any misuse, abuse, or improper application or installation of this product or use of the product for personal protection applications when the product is identified as not intended for such purposes will void the product warranty. Any modifications to this product without prior express approval by Banner Engineering Corp will void the product warranties. All specifications published in this document are subject to change; Banner reserves the right to modify product specifications or update documentation at any time. Specifications and product information in English supersede that which is provided in any other language. For the most recent version of any documentation, refer to: www.bannerengineering.com.

For patent information, see www.bannerengineering.com/patents.