

SSA-ISD Connect with Indication Product Manual



Original Instructions

p/n: 215320 Rev. F

22-Oct-24

© Banner Engineering Corp. All rights reserved.

Contents

Chapter 1 Product Overview

1.1 Models	3
1.2 Important... Read this before proceeding!	3
1.3 SSA-ISD Overview	4

Chapter 2 Installation Instructions

2.1 Mechanical Installation	5
2.2 Installation Requirements	5
2.3 Protective (Safety) Stop Circuits	6
2.4 Output Signal Switching Devices (OSSDs) and External Device Monitoring (EDM).....	6
2.4.1 Fault Tolerant Output Feature	7
2.5 Wiring	8
2.5.1 Wire the SSA-ISD Connect in a Chain of ISD E-Stops.....	9
2.5.2 Wire the SSA-ISD Connect in a Chain of ISD Interlocks.....	10
2.5.3 Wiring Additional Power Supplies	11
2.6 Checkout	13
2.7 In-Series Diagnostic (ISD) Information.....	13

Chapter 3 SSA-ISD Specifications

3.1 Dimensions	15
----------------------	----

Chapter 4 Accessories

4.1 Cordsets	16
4.2 Adapters and Other Accessories	19
4.3 Safety Controllers	19
4.4 ISD Connect Compatible Devices	19

Chapter 5 Product Support and Maintenance

5.1 Maintenance and Service	21
5.2 Status Indicators	21
5.3 EU/UK Declaration of Conformity (DoC)	22
5.4 Information Available Using ISD	22
5.5 Contact Us	24
5.6 Banner Engineering Corp Limited Warranty	24

Chapter Contents

1.1 Models 3
 1.2 Important... Read this before proceeding! 3
 1.3 SSA-ISD Overview 4

Chapter 1 Product Overview

SSA-ISD Connect with Indication

- Connects conventional emergency stop buttons or safe mechanical switch contacts to an ISD chain of devices
- Rugged design; easy installation with no assembly or individual wiring required
- 5-pin M12 female quick disconnect to connect an input device
- In-Series Diagnostic (ISD) for health and status information when used with a compatible Banner Safety Controller
- Built-in indication for input device status
- Built-in indication for ISD Status



1.1 Models

Model	Reset Function	Input Device Connector					Indication
		Pin 1	Pin 2	Pin 3	Pin 4	Pin 5	
SSA-ISD-TCA	No	CH1a	CH1b	NC	CH2a	CH2b	Green/Red
SSA-ISD-TCB	No	CH1a	CH1b	CH2a	CH2b	NC	Green/Red

1.2 Important... Read this before proceeding!

The user is responsible for satisfying all local, state, and national laws, rules, codes, and regulations relating to the use of this product and its application. Banner Engineering Corp. has made every effort to provide complete application, installation, operation, and maintenance instructions. Please contact a Banner Applications Engineer with any questions regarding this product.

The user is responsible for making sure that all machine operators, maintenance personnel, electricians, and supervisors are thoroughly familiar with and understand all instructions regarding the installation, maintenance, and use of this product, and with the machinery it controls. The user and any personnel involved with the installation and use of this product must be thoroughly familiar with all applicable standards, some of which are listed within the specifications. Banner Engineering Corp. makes no claim regarding a specific recommendation of any organization, the accuracy or effectiveness of any information provided, or the appropriateness of the provided information for a specific application.

WARNING:



- **Not a safeguarding device**
- Failure to follow these instructions could result in serious injury or death.
- This device is not considered a safeguarding device because it just converts the signal from an external device to an ISD compatible signal. A safeguarding or supplemental device with 2 normally closed (NC) contacts must be connected to this device. A safeguarding device limits or eliminates an individual's exposure to a hazard without action by the individual or others. This device cannot be substituted for required safeguarding. Refer to the applicable standards to determine those requirements.

1.3 SSA-ISD Overview

The SSA-ISD Connect with Indication is an adapter unit to integrate and serially connect Electromechanical Safety Switches (EMSSs) without ISD into machine designs.

This connector can be used to connect a safety point on a machine unsuitable for an existing ISD device, such as a panel mount e-stop or mechanical interlocks on a door. The SSA-ISD Connect interfaces with devices that have two normally closed (NC) safety contacts.

The indicators on the SSA-ISD Connect provide local diagnostics. One LED provides the status of the input device. The other LED provides the status of the OSSD inputs (ISD chain).

Chapter Contents

2.1 Mechanical Installation 5
 2.2 Installation Requirements 5
 2.3 Protective (Safety) Stop Circuits 6
 2.4 Output Signal Switching Devices (OSSDs) and External Device Monitoring (EDM) 6
 2.5 Wiring 8
 2.6 Checkout 13
 2.7 In-Series Diagnostic (ISD) Information 13

Chapter 2 Installation Instructions

2.1 Mechanical Installation

Install the SSA-ISD Connect to allow access for functional checks, maintenance, and service or replacement. Do not install the SSA-ISD Connect in such a way to allow for intentional defeat.

All mounting hardware is supplied by the user. Fasteners must be of sufficient strength to guard against breakage. Use of permanent fasteners or locking hardware is recommended to prevent the loosening or displacement of the device. The mounting hole (4.5 mm) in the SSA-ISD Connect accepts M4 (#6) hardware. See the figure below to help in determining the minimum screw length.

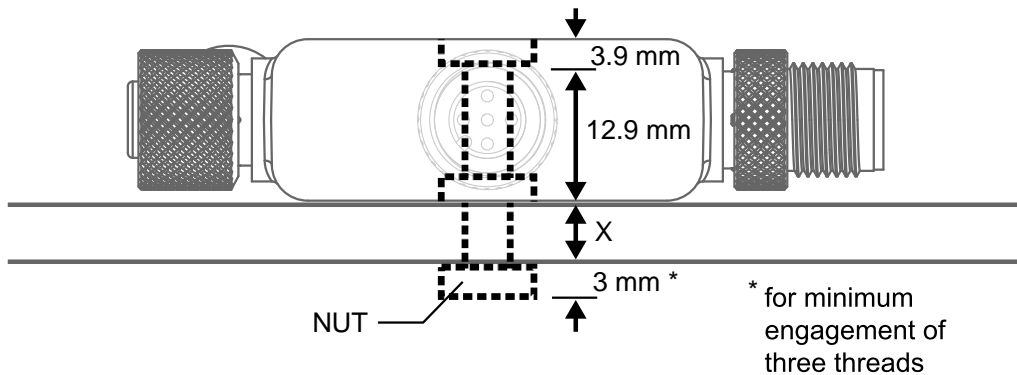

Screw Length (with screw head fitting in counterbore) = 12.9 mm + "X" mm + 3 mm



CAUTION: Do not overtighten the SSA-ISD Connect's mounting screw during installation. Overtightening can affect the performance of the SSA-ISD Connect.

IMPORTANT: It is the responsibility of the machine builder (user) to ensure the SSA-ISD Connect series wiring/cabling is not easily manipulated by an operator to defeat the safety function(s), for example, ensure the operator cannot remove a device from the chain.

2.2 Installation Requirements

The device is intended for indoor use only and must not be affected by environmental conditions. Do not expose the device to excessive shocks and vibrations, otherwise the device may be deformed or damaged, causing malfunction or operation failure.

Electrical installation must be made by qualified personnel⁽¹⁾ and must comply with NEC (National Electrical Code), NFPA 79 or IEC/EN 60204-1, and all applicable local standards. It is not possible to give exact wiring instructions for a device that

⁽¹⁾ A person who, by possession of a recognized degree or certificate of professional training, or who, by extensive knowledge, training and experience, has successfully demonstrated the ability to solve problems relating to the subject matter and work.

interfaces to a multitude of machine control configurations. The following is general in nature; it is recommended to perform a risk assessment to ensure appropriate application, interfacing/connection, and risk reduction (see ISO 12100 or ANSI B11.0).

WARNING:

- **Risk of electric shock**
- Use extreme caution to avoid electrical shock. Serious injury or death could result.
- Always disconnect power from the safety system (for example, device, module, interfacing, etc.), guarded machine, and/or the machine being controlled before making any connections or replacing any component. Lockout/tagout procedures might be required. Refer to OSHA 29CFR1910.147, ANSI Z244-1, or the applicable standard for controlling hazardous energy.
- Make no more connections to the device or system than are described in this manual. Electrical installation and wiring must be made by a Qualified Person⁽¹⁾ and must comply with the applicable electrical standards and wiring codes, such as the NEC (National Electrical Code), NFPA 79, or IEC 60204-1, and all applicable local standards and codes.

2.3 Protective (Safety) Stop Circuits

A protective (safety) stop allows for an orderly cessation of motion for safeguarding purposes, which results in a stop of motion and removal of power from the Machine Primary Control Elements (MPCE) (assuming this does not create additional hazards).

A protective stop circuit typically comprises a minimum of two normally open contacts from forced-guided, mechanically linked relays, which are monitored through External Device Monitoring (EDM) to detect certain failures, to prevent the loss of the safety function. Such a circuit can be described as a "safe switching point".

Protective stop circuits are either single-channel, which is a series connection of at least two normally open contacts, or dual-channel, which is a separate connection of two normally open contacts. In either method, the safety function relies on the use of redundant contacts to control a single hazard. If one contact fails On, the second contact arrests the hazards and prevents the next cycle from occurring.

Interface the protective stop circuits so that the safety function cannot be suspended, overridden, or defeated unless accomplished in a manner of the same or greater degree of safety as the machine's safety-related control system that includes the SSA-ISD Connect.

An ISD-compatible Banner Safety Controller, such as the SC10-2ro, provides a series connection of redundant contacts that form protective stop circuits for use in either single-channel or dual-channel control.

2.4 Output Signal Switching Devices (OSSDs) and External Device Monitoring (EDM)

The SSA-ISD Connect is able to detect faults on OSSD1 and OSSD2. These faults include short circuits to +24 V DC and 0 V, and between OSSD1 and OSSD2.

Both OSSD outputs must be connected to the machine control so that the machine's safety-related control system interrupts the circuit or power to the machine primary control element(s) (MPCE), resulting in a non-hazardous condition.

Final switching devices (FSDs) typically accomplish this when the OSSDs go to an OFF state.

Refer to the output specifications and these warnings before making OSSD output connections and interfacing the SSA-ISD Connect to the machine.

⁽¹⁾ A person who, by possession of a recognized degree or certificate of professional training, or who, by extensive knowledge, training and experience, has successfully demonstrated the ability to solve problems relating to the subject matter and work.

WARNING:

- **Interfacing both output signal switching devices (OSSD)**
- Failure to follow these instructions could result in serious injury or death.
- Unless the same degree of safety is maintained, never wire an intermediate device(s) (PLC, PES, PC) between the safety module outputs and the master stop control element it switches such that a failure causes a loss of the safety stop command or the failure allows the safety function to be suspended, overridden, or defeated.
- Connect both OSSD outputs to the machine control so that the machine's safety-related control system interrupts the circuit to the machine primary control element(s), resulting in a non-hazardous condition.

WARNING:

- **Interfacing OSSD Outputs to Machine Inputs**
- Failure to properly interface the OSSD Outputs to the guarded machine could result in serious injury or death.
- To ensure proper operation, the Banner device output parameters and machine input parameters must be considered when interfacing the Banner device OSSD outputs to machine inputs. Design the machine control circuitry so that the maximum load resistance value is not exceeded and the maximum specified OSSD Off-state voltage does not result in an On condition.

External device monitoring (EDM) is a function used to monitor the state of the external, positively guided (mechanically linked) machine control contacts (Final Switching Devices (FSD) and/or MPCEs). The SSA-ISD Connect does not include the EDM function. As a result, the SSA-ISD Connect should be used with an external safety monitoring device that monitors the status of the two SSA-ISD Connect OSSDs and is capable of providing the EDM function.

Examples of appropriate external safety monitoring devices include the Banner **SC10-2ro** or **XS26-ISDx** Safety Controller.

WARNING:

- **The SSA-ISD Connect does not have external device monitoring (EDM).**
- If EDM is required for the application, it must be implemented in the external control.

2.4.1 Fault Tolerant Output Feature

Faults that do not immediately compromise the safe operation of the SSA-ISD Connect (for example safety output to external potential, crosswire short safety output) result in a delayed switch-off of the safety outputs.

The safety outputs switch off when the error warning exceeds 20 minutes. In case of error warning, the SSA-ISD Connect will flash the ISD red LED.

Use this fault tolerance feature to run down the machinery in a controlled manner. After fixing the fault, the error message is confirmed by a voltage reset. The safe outputs enable and allow a restart.

Faults that directly affect the safe operation of the SSA-ISD Connect will immediately cause a lockout condition and the OSSDs will turn off.

2.5 Wiring

Figure 1. Wiring the SSA-ISD Connect to a panel mount Emergency Stop button

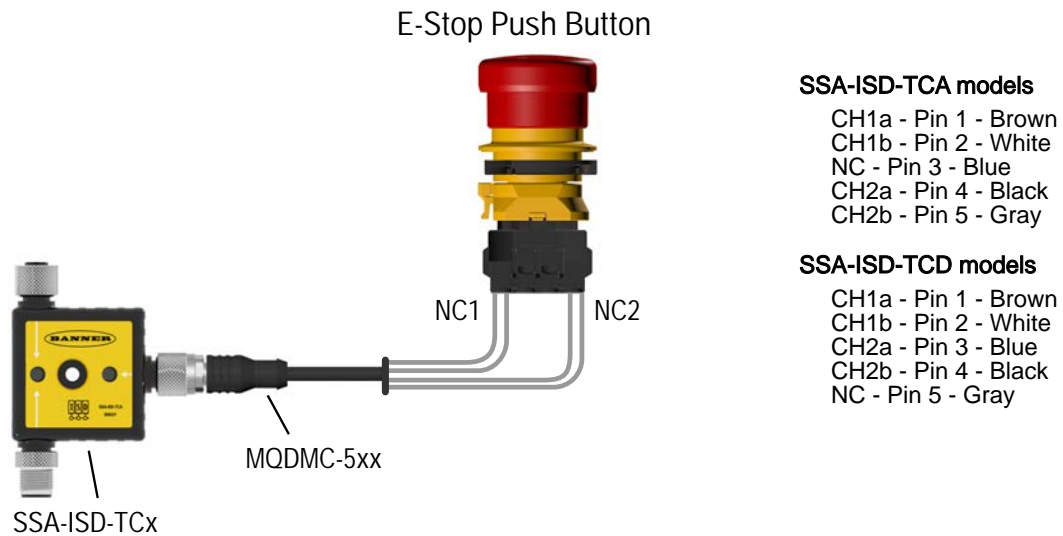
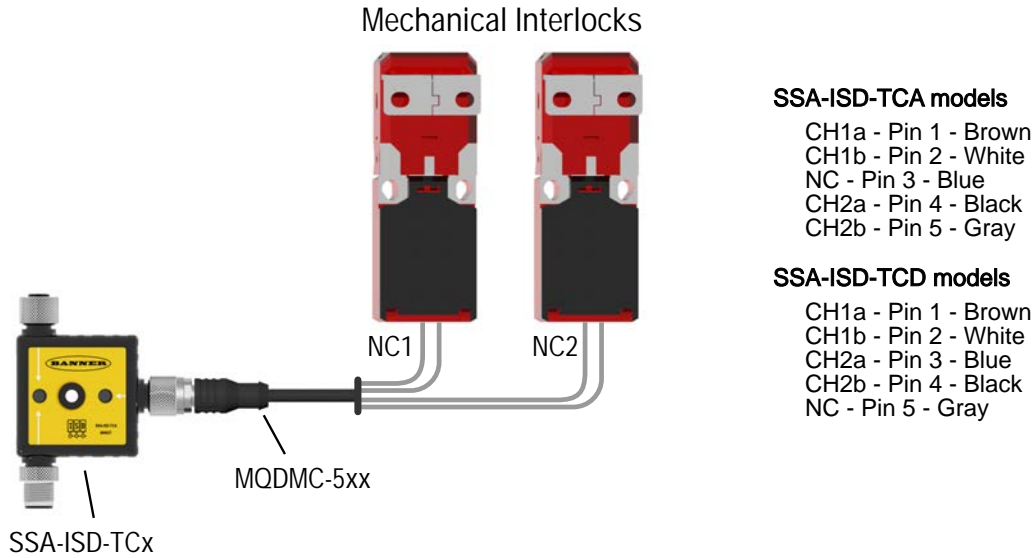

Figure 2. Wiring the SSA-ISD Connect to an SSA-EB1P-02ECQ5A E-stop button with a MQDEC-5xxSS cordset



For list of buttons compatible with each model of ISD Connect, see ["ISD Connect Compatible Devices"](#) on page 19.

Figure 3. Wiring the SSA-ISD Connect to mechanical interlocks



2.5.1 Wire the SSA-ISD Connect in a Chain of ISD E-Stops

When connecting emergency stop units in series, simplify the wiring by using special t-adapters, low-cost unshielded four-wire double-ended cables, and the SSA-ISD Connect with Indication.

A configuration of three lighted ISD e-stops and a panel mount e-stop is shown. The SSA-EB1PLx-0Dx E-stops, SI-RFD switches, and the SSA-ISD Connect can be combined in a single chain.

Figure 4. Wiring the SSA-ISD Connect in a chain of ISD e-stops

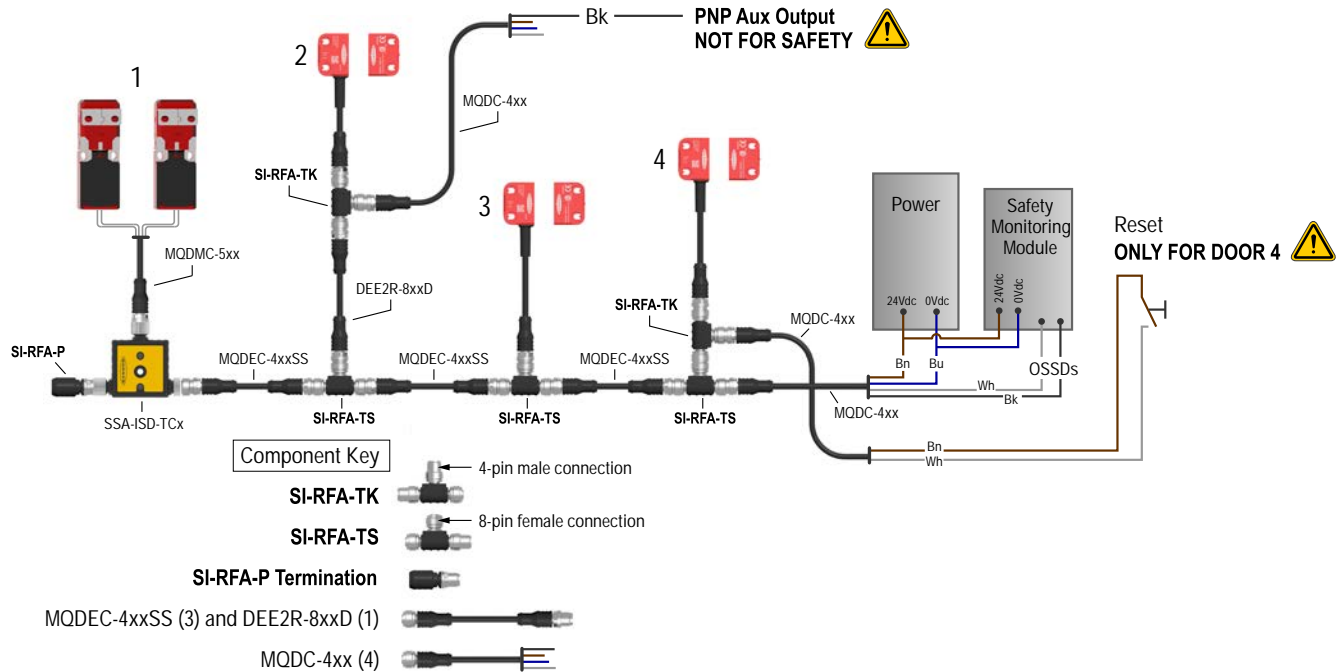

1. Connect the female 4-pin M12 cable to the male 4-pin M12 of the series connection t-adapter (SI-RFA-TS).
2. Connect your reset device.
 - If you are using a manual reset model of emergency stop device—Connect the female 8-pin M12 of the reset t-adapter (SI-RFA-TK) to the male 8-pin M12 connector of the series connection t-adapter.

4. Connect the male 4-pin M12 end of a double-ended cable to the female 4-pin M12 of the t-adapter. Connect the female end of the double ended cable to the next series connection t-adapter (SI-RFA-TS) or the SSA-ISD Connect.
5. At the end of the line, install a terminating plug (SI-RFA-P) to properly truncate the system.
6. Wire the wired end of the 4-pin M12 cable (from step 1) directly to a Safety Monitoring Device, such as an ISD-enabled Banner Safety Controller. You may also wire the 4-pin M12 cable to an In-Series Diagnostic (ISD) module then to the Safety Monitoring device.
7. Verify that the ISD chain of devices and the safety monitoring device are powered from the same power supply or the commons of the separate supplies are the same. Ensure that the voltage level at the ISD enabled device in position #1 (furthest from the power supply) is above 19.5 V for the system to operate properly.

2.5.3 Wiring Additional Power Supplies

For guidance on maximum total cable length and maximum number of devices before an additional power supply may be needed, see "Figure: Maximum total cable length for a single power supply on page 12. For using ISD information to monitor the individual device voltages, see "In-Series Diagnostic (ISD) Information" on page 13.

In a long series or series with many ISD devices, the voltage at all devices must stay above 19.5 V for proper operation. An additional power supply may be required to maintain a minimum of 19.5 V at all devices. There are three options to connect an additional power supply.

Figure 6. Option 1: Use a **SI-RFA-TK** Reset Connector in series with ISD Device. If available, set the power supplies for parallel output.

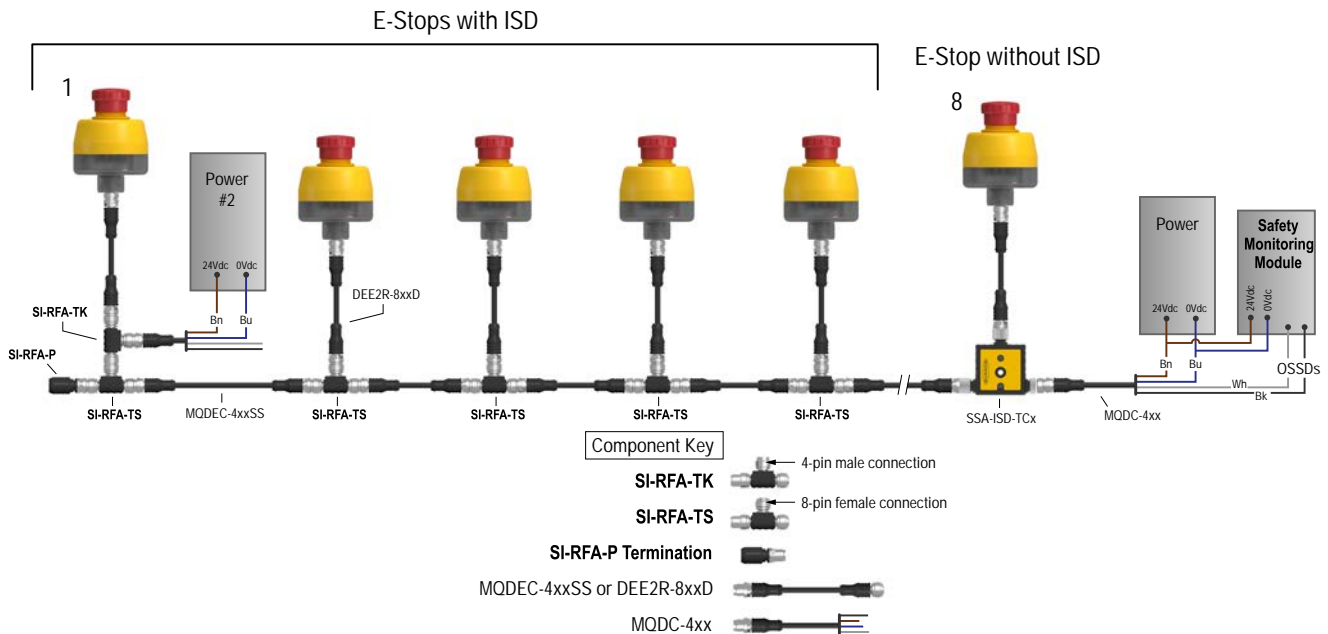

NOTE: Option 1 can only be used if the chain contains an SI-RFA-TS connector (the SI-RFA-TK cannot be connected to an SSA-ISD-TCx).

Figure 7. Option 2: Replace the terminator with a power supply. The OSSD1 and OSSD2 wires at power supply #2 must be connected to +24 V DC. If available, set the power supplies for parallel output.

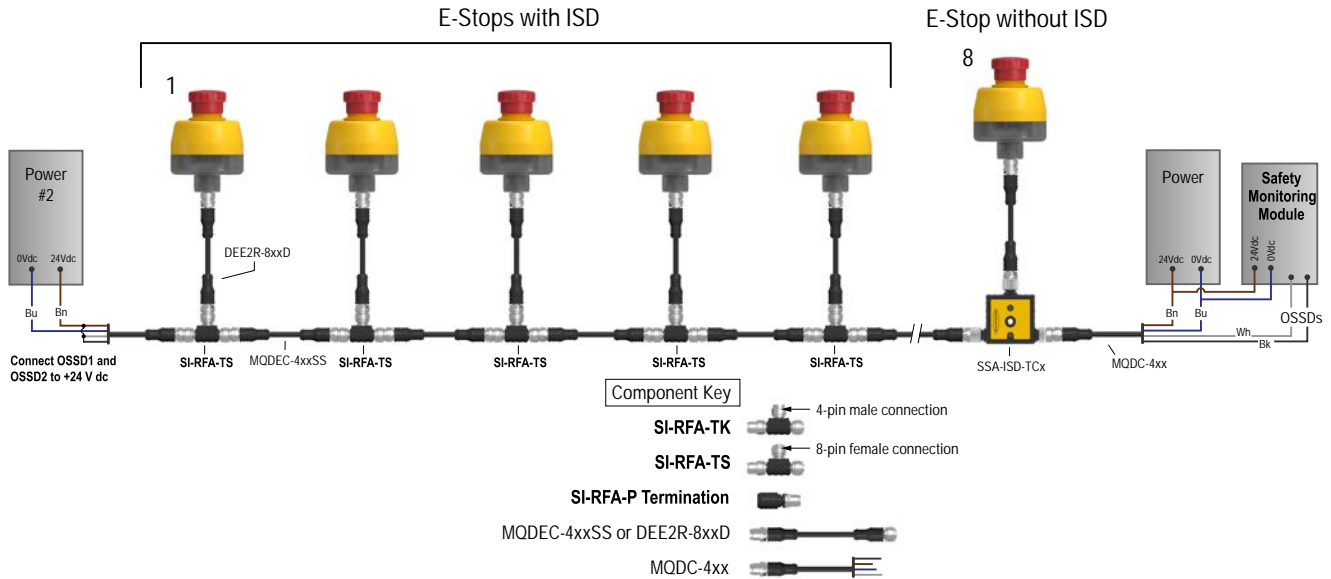

Option 3: Add a 4 or 5 pin splitter, like CSB-M1250M1250-T to the chain and connect the power on the open port via a 4 or 5 pin cable (ensuring the white and black lines are isolated).

Figure 8. Maximum total cable length for a single power supply

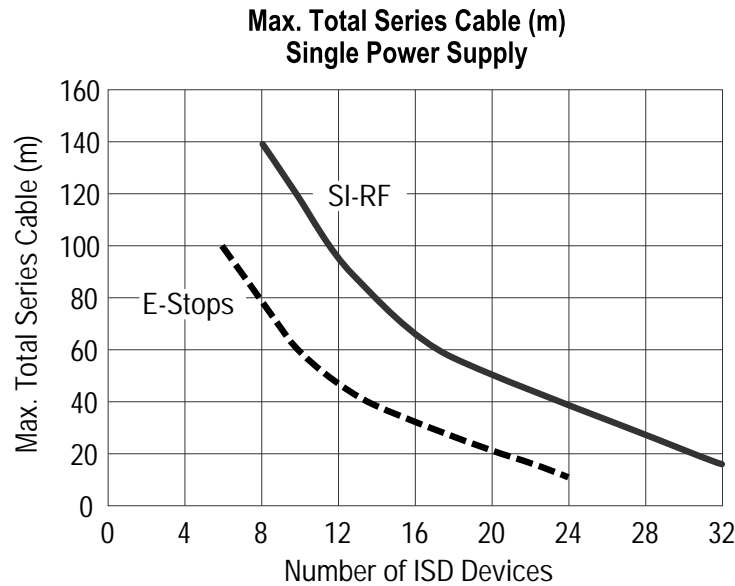

The ISD Connect has a similar current demand to the SI-RFD sensors. However, when used with a number of lighted ISD E-Stops, the current draw of the E-stops governs the cable lengths and when more power is needed.

WARNING:



- Safety devices with OSSDs and without ISD, such as safety light curtains, are not compatible.
- Failure to follow these instructions could result in serious injury or death.
- Do not use safety devices with OSSDs and without ISD in a series connection of multiple ISD devices.

NOTE:

- **Safety devices with solid-state OSSDs are not acceptable Input Devices**
- Failure to follow these instructions could result in serious injury or death.
- Only use safety devices with two normally closed (NC) contacts as input devices to the SSA-ISD Connect.

2.6 Checkout

At machine set up, a *Designated Person*⁽¹⁾ should test each safety point for proper machine shutdown response. A *Designated Person* should check the safety point for proper operation, physical damage, button looseness, and excessive environmental contamination. This should take place on a periodic schedule determined by the user, based on the severity of the operating environment and the frequency of switch actuations.

Adjust, repair, or replace components as needed. If inspection reveals contamination on the switch, thoroughly clean the switch and eliminate the cause of the contamination. Replace the switch and/or appropriate components when any parts or assemblies are damaged, broken, deformed, or badly worn; or if the electrical/mechanical specifications (for the environment and operating conditions) have been exceeded.

Always test the control system for proper functioning under machine control conditions after performing maintenance, replacing the safety point, or replacing any component of the device.

2.7 In-Series Diagnostic (ISD) Information

The information transmitted via the In-Series Diagnostic (ISD) interface is not safety-related. The diagnostic technology allows a wide range of device information to be loaded into the machine control system.

To interpret this information, Banner diagnostic modules are available, including the SI-RF-DM1 and -DM2 Diagnostic Modules and an ISD-enabled Safety Controller. Refer to the instruction manuals for detailed information on the diagnostic devices. By means of diagnostics, the following information can be transmitted, among others:

- Safety Device Status (on, off, or faulted)
- Under-voltages in the series connection (chain)
- Attempts to remove a device from the chain
- Wrong order of devices in the chain

At this time this information can be refined using the following interfaces:

- USB—Displays device information on the PC (requires using the SI-RF-DM1 or an ISD-enabled Safety Controller)
- IO-Link—Bus independent data reading into the control system (requires using the SI-RF-DM1 or SI-RF-DM2 and an IO-Link master)
- Industrial Ethernet Protocols—Bus data reading into the control system (requires using an ISD-enabled Safety Controller)

⁽¹⁾ A *Designated Person* is identified in writing by the employer as being appropriately trained to perform a specified checkout procedure. A *Qualified Person* possesses a recognized degree or certificate or has extensive knowledge, training, and experience to solve problems relating to the emergency stop installation.

Chapter Contents

3.1 Dimensions..... 15

Chapter 3 SSA-ISD Specifications

IMPORTANT: Interface the SSA-ISD Connect with Indication only to a SELV (Safety Extra-Low Voltage) for circuits without earth ground or a PELV (Protected Extra-Low Voltage) for circuits with earth ground power supply according to EN/IEC 60950.

Rated Supply Voltage (Ue)

24 V DC +15%, -20% (SELV/PELV power supply)

The external voltage supply must be capable of buffering brief mains interruptions of 20 ms, as specified in IEC/EN 60204-1.

Rated Conditional Short-Circuit Current

100 A

Rated Isolation Voltage (Ui)

75 V DC

No-Load Current

60 mA typical at 24 V DC

75 mA maximum at 19.2 V DC

Rated Impulse Withstand Voltage (Uimp)

500 V

OSSD Outputs

Two, solid-state, current sourcing PNP outputs

Switching element function: PNP, NO

Voltage level: according to Type 3 EN 61131-2

Maximum operating current: 30 mA

Leakage current: ≤ 1 mA DC

On-state voltage: ≥ Ue – 3 V

Protection: Sustained short circuit and overload protection; thermal / digital (clocking)

Test pulse duration: 70 us

Test pulse rate: 1 s

Input Device Requirements

Accepts two normally closed (NC) contacts

Maximum resistance: 100 Ω

Maximum cable length: 30 m (98.4 ft)

Simultaneity Requirement

Three seconds

Indication

Red (618 nm), Green (525 nm)

Housing/connectors

Housing: Polyvinyl Chloride (PVC), Black

Connector Nuts: Nickel plating on Cu/Zn alloy

Power Up Delay

≤ 2 s

Response Time

40 ms maximum + (7 ms x number of following ISD devices)

Maximum Cable Length Between ISD Devices

30 m (98.4 ft)

Vibration Resistance

Operating extremes: 10 Hz to 500 Hz, amplitude 0.35 mm, acceleration 50 m/s²

Operating Conditions

-25 °C to +55 °C (-13 °F to +131 °F)

45% to 85% relative humidity (no condensation)

Environmental Ratings

For Indoor Use Only

IP65, IP67 (EN 60529)

EMC

According to EN 61326-1 and EN 61326-3-1

Safety Data

SIL 3 (IEC 61508)

SILCL 3 (EN 62061)

Category 4, PL e (EN ISO 13849-1)

PFHD: 6.56 × 10⁻⁹ 1/h according to EN 62061

Service Life: 20 years

Certifications



Banner Engineering BV
Park Lane, Culliganlaan 2F bus 3
1831 Diegem, BELGIUM



Turck Banner LTD Blenheim House
Blenheim Court
Wickford, Essex SS11 8YT
GREAT BRITAIN



Required Overcurrent Protection



WARNING: Electrical connections must be made by qualified personnel in accordance with local and national electrical codes and regulations.

Overcurrent protection is required to be provided by end product application per the supplied table.

Overcurrent protection may be provided with external fusing or via Current Limiting, Class 2 Power Supply.

Supply wiring leads < 24 AWG shall not be spliced.

For additional product support, go to www.bannerengineering.com.

Supply Wiring (AWG)	Required Overcurrent Protection (A)	Supply Wiring (AWG)	Required Overcurrent Protection (A)
20	5.0	26	1.0
22	3.0	28	0.8
24	1.0	30	0.5

3.1 Dimensions

All measurements are listed in millimeters, unless noted otherwise. The measurements provided are subject to change.

Figure 9. SSA-ISD-TCA

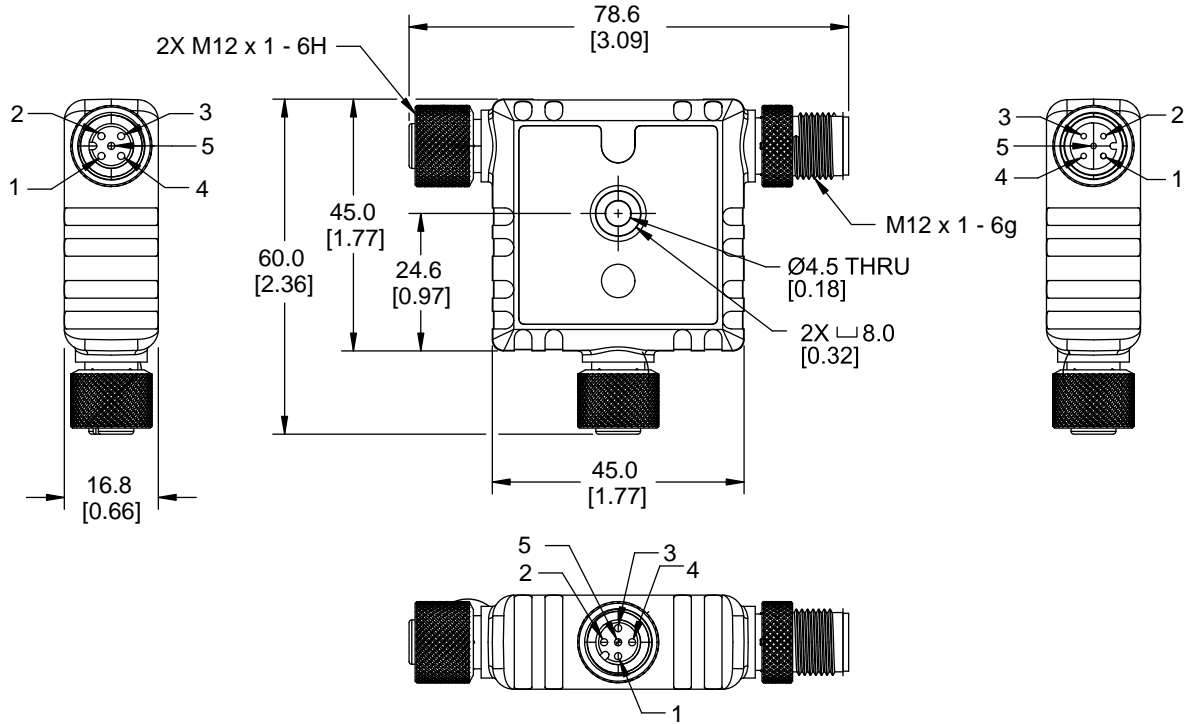
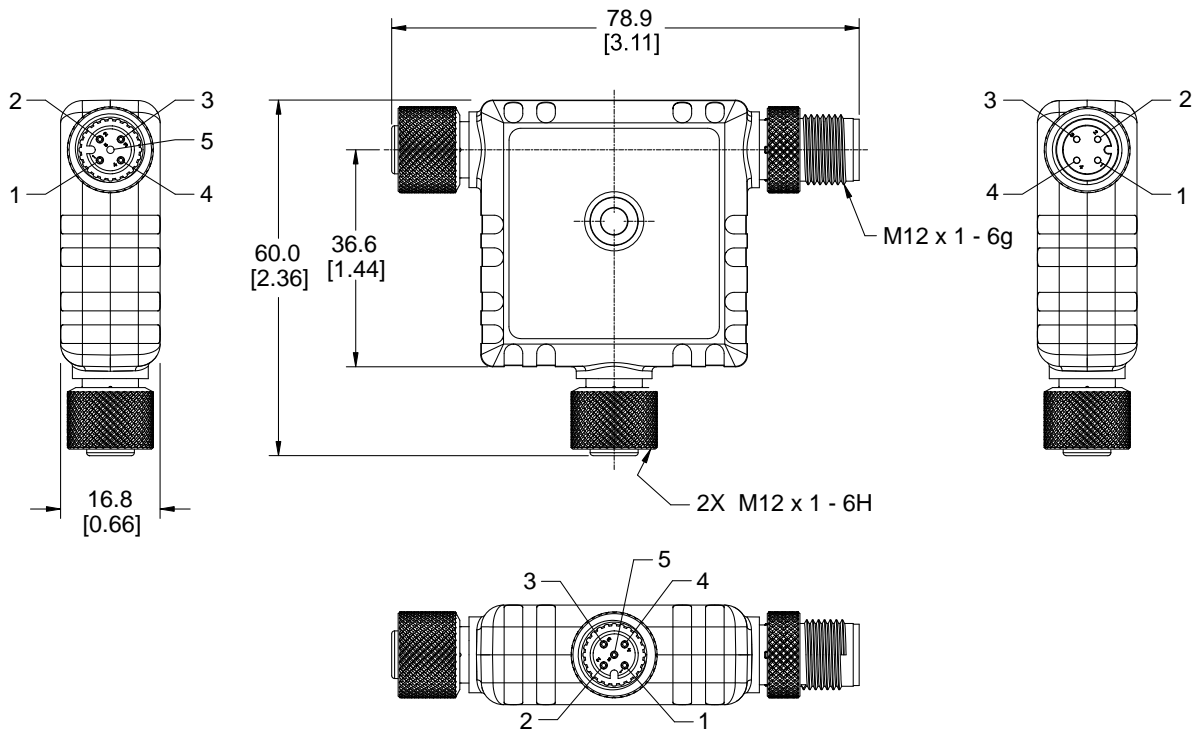

Figure 10. SSA-ISD-TCD



Chapter Contents

4.1 Cordsets 16
 4.2 Adapters and Other Accessories 19
 4.3 Safety Controllers 19
 4.4 ISD Connect Compatible Devices 19

Chapter 4 Accessories

4.1 Cordsets

4-Pin Single-Ended M12 Female Cordsets				
Model	Length	Style	Dimensions	Pinout (Female)
MQDC-406	2 m (6.56 ft)	Straight		
MQDC-415	5 m (16.4 ft)			
MQDC-430	9 m (29.5 ft)			
MQDC-450	15 m (49.2 ft)			
MQDC-406RA	2 m (6.56 ft)	Right-Angle		
MQDC-415RA	5 m (16.4 ft)			
MQDC-430RA	9 m (29.5 ft)			
MQDC-450RA	15 m (49.2 ft)			

1 = Brown
 2 = White
 3 = Blue
 4 = Black
 5 = Unused

5-Pin Single-Ended M12 Female Cordsets				
Model	Length	Style	Dimensions	Pinout (Female)
MQDC1-501.5	0.5 m (1.5 ft)	Straight		
MQDC1-503	0.9 m (2.9 ft)			
MQDC1-506	2 m (6.5 ft)			
MQDC1-515	5 m (16.4 ft)			
MQDC1-530	9 m (29.5 ft)			
MQDC1-560	18 m (59 ft)			
MQDC1-5100	31 m (101.7 ft)			
MQDC1-506RA	2 m (6.5 ft)	Right-Angle		
MQDC1-515RA	5 m (16.4 ft)			
MQDC1-530RA	9 m (29.5 ft)			
MQDC1-560RA	19 m (62.3 ft)			

1 = Brown
 2 = White
 3 = Blue
 4 = Black
 5 = Gray

4-Pin Single-Ended M12 Male Cordsets				
Model	Length	Style	Dimensions	Pinout (Male)
MQDMC-401	0.23 m (0.75 ft)	Straight		
MQDMC-406	2 m (6.7 ft)			
MQDMC-415	5 m (15.4 ft)			
MQDMC-430	10 m (32.9 ft)	Right-angle		<p>1 = Brown 2 = White 3 = Blue 4 = Black</p>
MQDMC-406RA	1.8 m (6 ft)			
MQDMC-415RA	4.5 m (15 ft)			
MQDMC-430RA	9.1 m (30 ft)			

5-Pin Single-Ended M12 Male Cordsets				
Model	Length	Style	Dimensions	Pinout (Male)
MQDMC-501	0.3 m (1 ft)	Straight		
MQDMC-506	2.04 m (6.69 ft)			
MQDMC-515	5.04 m (16.5 ft)			
MQDMC-530	9.04 m (29.7 ft)			
MQDMC-550	15 m (49.2 ft)			
MQDMC-506RA	2 m (6.56 ft)	Right-Angle		<p>1 = Brown 2 = White 3 = Blue 4 = Black 5 = Gray</p>
MQDMC-515RA	5 m (16.4 ft)			
MQDMC-530RA	9 m (29.5 ft)			

4-Pin Double-Ended M12 Female to M12 Male Cordsets				
Model	Length	Style	Dimensions	Pinout
MQDEC-401SS	0.31 m (1 ft)	Male Straight / Female Straight		<p>Female</p>
MQDEC-403SS	0.91 m (2.99 ft)			
MQDEC-406SS	1.83 m (6 ft)			
MQDEC-412SS	3.66 m (12 ft)			
MQDEC-415SS	4.58 m (15 ft)			
MQDEC-420SS	6.10 m (20 ft)			
MQDEC-430SS	9.14 m (30.2 ft)			
MQDEC-450SS	15.2 m (49.9 ft)	<p>Male</p>		

Continued on page 18

- 1 = Brown
- 2 = White
- 3 = Blue
- 4 = Black



Continued from page 17

4-Pin Double-Ended M12 Female to M12 Male Cordsets					
Model	Length	Style	Dimensions	Pinout	
MQDEC-403RS	0.91 m (2.99 ft)	Male Right-Angle / Female Straight			
MQDEC-406RS	1.83 m (6 ft)				
MQDEC-412RS	3.66 m (12 ft)				
MQDEC-420RS	6.10 m (20 ft)				
MQDEC-430RS	9.14 m (30.2 ft)				
MQDEC-450RS	15.2 m (49.9 ft)				
MQDEC-403RR	0.9 m (2.9 ft)	Male Right-Angle / Female Right-Angle			
MQDEC-406RR	1.8 m (5.9 ft)				
MQDEC-412RR	3.6 m (11.8 ft)				
MQDEC-420RR	6.1 m (20 ft)				

5-Pin Double-Ended M12 Female to M12 Male Cordsets					
Model	Length	Style	Dimensions	Pinout (Male)	Pinout (Female)
MQDEC-501SS	0.31 m (1.02 ft)	Male Straight/ Female Straight			
MQDEC-503SS	0.91 m (2.99 ft)				
MQDEC-506SS	1.83 m (6 ft)				
MQDEC-512SS	3.66 m (12 ft)				
MQDEC-515SS	5 m (16.4 ft)				
MQDEC-530SS	9 m (29.5 ft)				
MQDEC-550SS	15 m (49.2 ft)			<p>1 = Brown 2 = White 3 = Blue</p>	<p>4 = Black 5 = Gray</p>

5-Pin Double-Ended M12 Female to M12 Male Cordsets					
Model	Length	Style	Dimensions	Pinout (Male)	Pinout (Female)
MQDEC-501RS	0.31 m (1.02 ft)	Male Right-angle/ Female Straight			
MQDEC-503RS	0.91 m (2.99 ft)				
MQDEC-506RS	1.83 m (6 ft)				
MQDEC-512RS	3.66 m (12 ft)				
				<p>1 = Brown 2 = White 3 = Blue</p>	<p>4 = Black 5 = Gray</p>

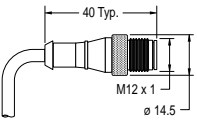
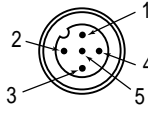
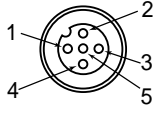
5-Pin Double-Ended M12 Female to M12 Male Cordsets					
Model	Length	Style	Dimensions	Pinout (Male)	Pinout (Female)
DEE2R-51D	0.3 m (1 ft)	Female Straight/ Male Straight			
DEE2R-53D	0.91 m (3 ft)				
DEE2R-58D	2.44 m (8 ft)				
DEE2R-515D	4.57 m (15 ft)				
DEE2R-525D	7.62 m (25 ft)				
DEE2R-550D	15.2 m (50 ft)				
DEE2R-575D	22.9 m (75 ft)				
DEE2R-5100D	30.5 m (100 ft)				
				1 = Brown 2 = White 3 = Blue	4 = Black 5 = Green/ Yellow

4.2 Adapters and Other Accessories

Model	Description
SI-RFA-TS	SI-RF T-adapter for series connection, 4 pin to 8 pin to 4 pin, IP68 rated
SI-RFA-TK	SI-RF T-adapter for connection of the reset button, 8 pin to 4 pin to 8 pin, IP68 rated
SI-RFA-P	SI-RF Termination plug M12, IP68 rated
SI-RFA-DM1	SI-RF Diagnostic Module with 8 digital outputs and 1 diagnostic circuit Interfaces: IO-Link, USB 2.0
SI-RDA-DM2	SI-RF Diagnostic Module with 1 diagnostic circuit, IP69 rated Interfaces: IO-Link
CSB-M1250M1250-T	Splitter that can be used to add power between ISD devices

4.3 Safety Controllers

Safety Controllers provide a fully configurable, software-based safety logic solution for monitoring safety and non-safety devices.

For additional models and XS26 expansion modules, see instruction manual p/n [174868](#).

Table 1. Safety controller models

Non-Expandable Models	Expandable Models	Description
SC26-2	XS26-2	26 convertible I/O and 2 redundant solid-state safety outputs
SC26-2d	XS26-2d	26 convertible I/O and 2 redundant solid-state safety outputs with display
SC26-2e	XS26-2e	26 convertible I/O and 2 redundant solid-state safety outputs with Ethernet
SC26-2de	XS26-2de	26 convertible I/O and 2 redundant solid-state safety outputs with display and Ethernet
SC10-2roe		10 inputs, 2 redundant relay safety outputs (3 contacts each) (ISD and Ethernet compatible)
	XS26-ISDd	26 inputs, 2 redundant solid-state safety outputs with display, Ethernet, and 8 ISD channels

4.4 ISD Connect Compatible Devices

The following tables list devices that can be directly connected to the ISD Connect via Quick Disconnect cables.

The following E-stops with Quick Disconnect connectors can be directly connected to the SSA-ISD-TCx using a MQDEC-5xxSS or DEE2R-5xxD cable.

Model	Push Button	Housing	E-Stop Contacts	Compatible ISD Connect
SSA-EB1P-02ECQ5A	Standard 40 mm	30 mm mount	2 NC	SSA-ISD-TCA
SSA-EB2P-02ECQ5A	Large 60 mm	30 mm mount	2 NC	SSA-ISD-TCA
SSA-EB1P-02ED1Q5A	Standard 40 mm	Flush mount	2 NC	SSA-ISD-TCA
SSA-EB2P-02ED1Q5A	Large 60 mm	Flush mount	2 NC	SSA-ISD-TCA

Continued on page 20

Continued from page 19

Model	Push Button	Housing	E-Stop Contacts	Compatible ISD Connect
SA-EB1PM-02ED1Q5A	Lockable 44 mm	Flush mount	2 NC	SSA-ISD-TCA
SSA-EB1PL2-02ECQ5A	Illuminated 40 mm	30 mm mount	2 NC	SSA-ISD-TCA
SSA-EB1P-02ECQ4C	Standard 40 mm	30 mm mount	2 NC	SSA-ISD-TCD

The following Safety Limit and Hinge Switches with Quick Disconnect connectors can be directly connected to the SSA-ISA-TCA with splitter cable CSE5A-M1251M1251 and MQDEC-5xxSS or DEE2R-5xxD if needed. The SI-HG(Z)63 units need a MQEAC-601-Q5A adapter cable per switch.

Model	Style	Housing Material	Contact Configuration	Compatible ISD Connect
SI-LS83E-Q5A ⁽¹⁾	Limit Switch	Plastic	2 NC	SSA-ISD-TCA
SI-LS100F-Q5A ⁽¹⁾	Limit Switch	Plastic	2 NC/1 NO	SSA-ISD-TCA
SI-QM90E-Q5A ⁽¹⁾	Limit Switch	Plastic	2 NC	SSA-ISD-TCA
I-HG63FQDL	Hinge	Stainless Steel	2 NC/1 NO	SSA-ISD-TCA
SI-HGZ63FQDL	Hinge	Zinc Diecast	2 NC/1 NO	SSA-ISD-TCA
SI-HG63FQDR	Hinge	Stainless Steel	2 NC/1 NO	SSA-ISD-TCA
SI-HGZ63FQDR	Hinge	Zinc Diecast	2 NC/1 NO	SSA-ISD-TCA
SI-HG63FQDRR	Hinge	Stainless Steel	2 NC/1 NO	SSA-ISD-TCA
SI-HG63FQDRR	Hinge	Zinc Diecast	2 NC/1 NO	SSA-ISD-TCA
SI-GL42DM01-20Q13 ⁽¹⁾	Locking	Metal/Plastic	2 NC/1 NO	SSA-ISD-TCA
SI-GL42DS01-20Q13 ⁽¹⁾	Locking	Metal/Plastic	2 NC/1 NO	SSA-ISD-TCA

⁽¹⁾ Actuator, cable gland, and/or conduit adapter ordered separately.

Chapter Contents

5.1 Maintenance and Service..... 21
 5.2 Status Indicators..... 21
 5.3 EU/UK Declaration of Conformity (DoC) 22
 5.4 Information Available Using ISD..... 22
 5.5 Contact Us..... 24
 5.6 Banner Engineering Corp Limited Warranty..... 24

Chapter 5 Product Support and Maintenance

5.1 Maintenance and Service

Do not use alcoholic cleaning agents.

The SSA-ISD Connect is maintenance-free.

For long-term and trouble-free operation, please periodically check the following points:

- solid fit of all components
- reliable switching function
- if damage occurs, please exchange the relevant components

Liability disclaimer— By breach of the given instructions (concerning the intended use, the safety instructions, the installation and connection through qualified personnel and the testing of the safety function) manufacturer’s liability expires.

5.2 Status Indicators

The SSA-ISD Connect with Indication has matching indicators on both sides to allow for installation needs and still provide adequate indication visibility. Each indicator displays both red and green. When power is applied, both LEDs flash red/green/off, then turn on in the appropriate state (red or green).

Figure 11. SSA-ISD Connect status indicators

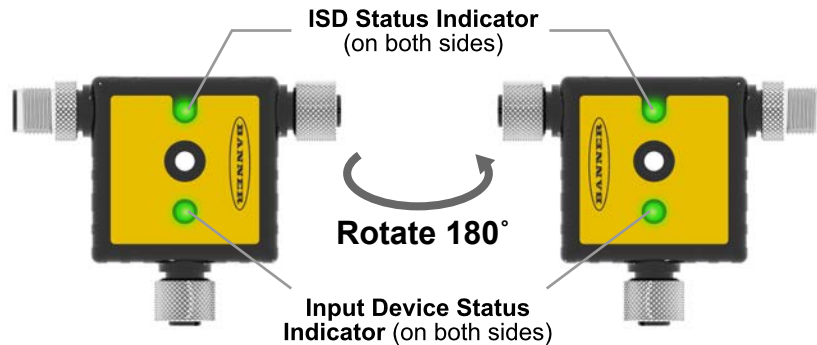

Input Device Status (Two NC Contact Status)	OSSD Inputs	SSA-ISD Connect Status	OSSD Outputs	Input Device LED	ISD Status LED
Run State (closed)	On	Normal	On	Green	Green
Run State (closed)	Off	Normal	Off	Green	Red
Off State (open)	On	Normal	Off	Red	Green
Off State (open)	Off	Normal	Off	Red	Red
x	x	Fault (Volt. Mon)	Off	Red Flashing	Red Flashing
Run State (closed)	On	Fault (OSSD)	On/Off ⁽¹⁾	Red Flashing	Red Flashing
x	x	Fault (internal)	Off	Red Flashing	Red Flashing

⁽¹⁾ OSSD Fault Tolerant Mode: OSSDs remain on for 20 minutes then turn off. For more information, see ["Fault Tolerant Output Feature" on page 7](#).

5.3 EU/UK Declaration of Conformity (DoC)

Banner Engineering Corp. herewith declares that these products are in conformity with the provisions of the listed directives and all essential health and safety requirements have been met. For the complete DoC, please go to www.bannerengineering.com.

Product	Directive
SSA-ISD Connect with Indication	EU: Machinery Directive 2006/42/EC
	UKCA: Machinery (Safety) Regulation 2008

Representative in EU: Spiros Lachandidis, Managing Director, **Banner Engineering BV** Park Lane | Culliganlaan 2F bus 3 | 1831 Diegem, BELGIUM

Representative in UK: Tony Coghlan, Managing Director, **Turck Banner LTD** Blenheim House | Blenheim Court | Wickford, Essex SS11 8YT | Great Britain

5.4 Information Available Using ISD

Obtain the following information from the ISD chain and a diagnostic unit or an ISD-enabled Safety Controller.

Information	Type	Data Size	Steps to Resolve
ISD chain count does not match configuration (XS26-ISD FID 5 or later (only when not using Auto Detect mode) and SC10 FID 2 or later.)	Controller Alert	1 bit	Check the number of physical units against the number configured in the chain
ISD chain order does not match configuration (XS26-ISD FID 5 or later (only when not using Auto Detect mode) and SC10 FID 2 or later.)	Controller Alert	1 bit	Check the order of the physical units against the configured order. Note the location of the terminator plug and the controller.
ISD data update pending (no data or buffered data)	Controller Alert	1 bit	Caused by non-ISD devices in chain or a buffering situation If the data is not present from power up (never present): <ul style="list-style-type: none"> Verify that all devices in ISD Chain are ISD enabled devices If data was present but then lost: <ul style="list-style-type: none"> Verify that the chain has not been broken Data could be disrupted and will return in a few seconds
Invalid (non-ISD) device in ISD chain	Controller Alert	1 bit	Incorrect data types are being received <ul style="list-style-type: none"> Verify that all devices in the chain are Banner ISD devices
ISD device detected but not configured (<i>reserved</i> in XS26-ISD)	Informative	1 bit	<ul style="list-style-type: none"> Verify the ISD chain is wired to the correct terminals Verify that the correct input device type (ISD) was selected for this input in the configuration.
ISD chain terminator plug missing	ISD Status	1 bit	<ul style="list-style-type: none"> Verify that the terminator plug has not come loose Verify that the chain has not been broken (loose connections)
SI-RF high or unique sensor not taught an actuator	ISD Fault	1 bit	An SI-RF switch (-UP8 or -HP8) have not been taught <ul style="list-style-type: none"> Configure the unit to its actuator per instructions in Banner datasheet p/n 208885
Wrong actuator presented to a high or unique sensor	ISD Fault	1 bit	An SI-RF switch (-UP8 or -HP8) is seeing an actuator but not the one to which it was configured. <ul style="list-style-type: none"> Check for tampering (wrong actuator being used) Teach High coded sensor (-HP8) the new actuator

Continued on page 23

Continued from page 22

Information	Type	Data Size	Steps to Resolve
Internal error on an ISD device in the chain	ISD Fault	1 bit	<ul style="list-style-type: none"> Verify which device has the error, cycle power to the system If the error persists, replace the device
ISD Output fault detected, output turn off counter started	ISD Fault	1 bit	ISD device output will turn off in 20 minutes <ul style="list-style-type: none"> Verify which device has the error, check wiring for shorts Cycle power, if issue persists, replace the device
Change in ISD chain detected (only in XS26-ISD FID 5 or later)	ISD Status	1 bit	If AutoDetect ISD is configured and an ISD chain length or order has changed, this flag will be set and must be recognized by the PLC.
ISD Count Change from Baseline Detected	ISD Status	1 bit	ISD device count has changed from the baseline count, verify the chain device count matches machine configuration.
ISD Chain output signal switching device (OSSD) status	ISD Status	1 bit	

Individual Unit Data - Flags		
Short Name	Data Format	Description
Actuator detected	1/0	Not applicable
Wrong actuator detected/Input status	1/0	Input device's connect status
Sensor not paired	1/0	Not applicable
Output 1	1/0	Output 1 is on
Output 2	1/0	Output 2 is on
Marginal range/Input status	1/0	Input device's contact status
Input 1	1/0	ISD device input 1 is on
Input 2	1/0	ISD device input 2 is on
Local reset expected	1/0	An ISD device with the latch feature requires a reset
Operating voltage warning	1/0	Voltage to the ISD device is at the limit of specifications
ISD data error	1/0	ISD error bit, corrupted data was received from the SI-RF ISD chain of switches.
Safety input fault	1/0	The system detected a fault on a safety input of an ISD device, power cycle required
Output error	1/0	ISD Device detects an output short to voltage or ground. This starts the "switch-off timer" counter.
Operating voltage error	1/0	Voltage to the ISD Device is above (over 30 V DC) or below (less than 19.2 V DC) limit of the range.
Power cycle required	1/0	ISD Device detects a fault, a power cycle is required.

Individual Unit Data - Configuration		
Short Name	Data Format	Description
Local reset unit	1/0	The ISD Device includes the latch feature
High coding level	1/0	Not applicable
Cascadable	1/0	The ISD Device includes the cascade feature Note: This will always be true for Emergency Stop models with ISD and for the ISD Connect.
Fault tolerant outputs	1/0	Indicates that the ISD Device includes the fault tolerant output feature where output faults cause a 20 minute off delay/fault delay. Note: This will always be true for Emergency Stop models with ISD.

Individual Unit Data - Values		
Short Name	Data Format	Description
Device		Type of ISD Device
Expected code		Not applicable
Received code		Not applicable
Teach-ins remaining	number	Not applicable
Number of voltage errors	number	The number of voltage warnings received in the last 60 seconds (voltage is checked every second), a number between 0 and 60
Number of operations	number	The number of on/off cycles the device has experienced
Output switch-off time	number	The delay counter for certain output faults (0 - inactive, 20 to 1 - remaining minutes to device lockout state)

Continued on page 24

Continued from page 23

Individual Unit Data - Values		
Short Name	Data Format	Description
Range warning count	number	Not applicable
Supply voltage	number	The actual input voltage detected by the ISD device.
Internal temperature	number	The internal temperature of the ISD device (°C)
Actuator distance	number	Not applicable
Expected company name		Not applicable, value of 6 will be received
Received company name		Not applicable, this is the code received from an actuator (for RFID switches)

NOTE: If an ISD chain is in operation and is severed (for example, a cable is cut, a cable came loose, etc.), the ISD information stops. After a number of seconds (approximately 5 seconds) the information resumes minus the devices that have been separated from the chain.

5.5 Contact Us

Banner Engineering Corp. headquarters is located at: 9714 Tenth Avenue North | Plymouth, MN 55441, USA | Phone: + 1 888 373 6767

For worldwide locations and local representatives, visit www.bannerengineering.com.

5.6 Banner Engineering Corp Limited Warranty

Banner Engineering Corp. warrants its products to be free from defects in material and workmanship for one year following the date of shipment. Banner Engineering Corp. will repair or replace, free of charge, any product of its manufacture which, at the time it is returned to the factory, is found to have been defective during the warranty period. This warranty does not cover damage or liability for misuse, abuse, or the improper application or installation of the Banner product.

THIS LIMITED WARRANTY IS EXCLUSIVE AND IN LIEU OF ALL OTHER WARRANTIES WHETHER EXPRESS OR IMPLIED (INCLUDING, WITHOUT LIMITATION, ANY WARRANTY OF MERCHANTABILITY OR FITNESS FOR A PARTICULAR PURPOSE), AND WHETHER ARISING UNDER COURSE OF PERFORMANCE, COURSE OF DEALING OR TRADE USAGE.

This Warranty is exclusive and limited to repair or, at the discretion of Banner Engineering Corp., replacement. **IN NO EVENT SHALL BANNER ENGINEERING CORP. BE LIABLE TO BUYER OR ANY OTHER PERSON OR ENTITY FOR ANY EXTRA COSTS, EXPENSES, LOSSES, LOSS OF PROFITS, OR ANY INCIDENTAL, CONSEQUENTIAL OR SPECIAL DAMAGES RESULTING FROM ANY PRODUCT DEFECT OR FROM THE USE OR INABILITY TO USE THE PRODUCT, WHETHER ARISING IN CONTRACT OR WARRANTY, STATUTE, TORT, STRICT LIABILITY, NEGLIGENCE, OR OTHERWISE.**

Banner Engineering Corp. reserves the right to change, modify or improve the design of the product without assuming any obligations or liabilities relating to any product previously manufactured by Banner Engineering Corp. Any misuse, abuse, or improper application or installation of this product or use of the product for personal protection applications when the product is identified as not intended for such purposes will void the product warranty. Any modifications to this product without prior express approval by Banner Engineering Corp will void the product warranties. All specifications published in this document are subject to change; Banner reserves the right to modify product specifications or update documentation at any time. Specifications and product information in English supersede that which is provided in any other language. For the most recent version of any documentation, refer to: www.bannerengineering.com.

For patent information, see www.bannerengineering.com/patents.

 [LinkedIn](#)

 [X \(formerly Twitter\)](#)

 [Facebook](#)

