

Performance Curves

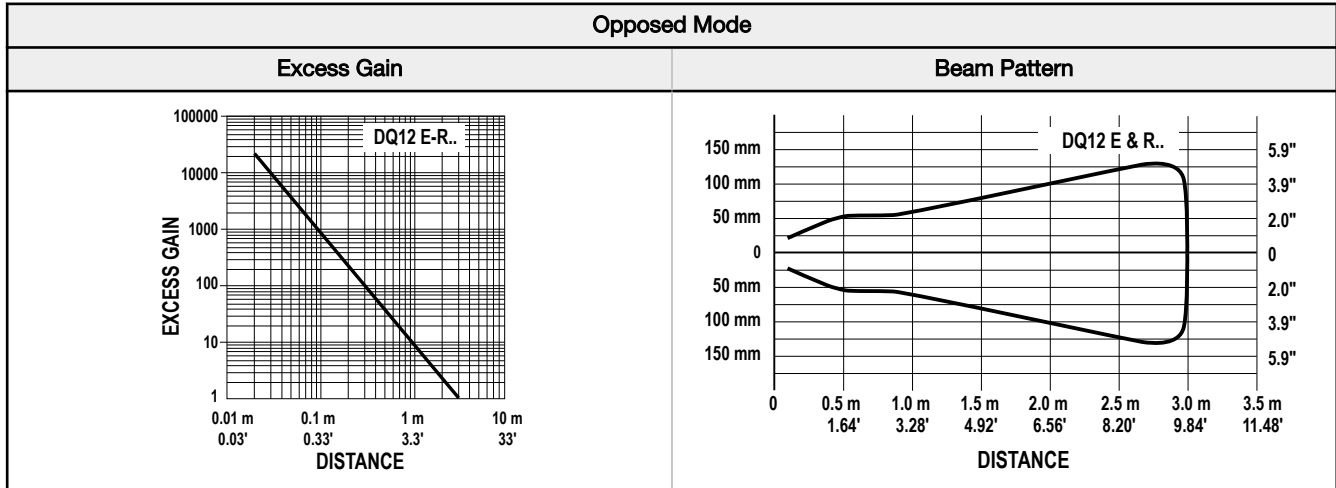

Retroreflective and polarized retroreflective performance is based on the use of a model BRT-60X40C retroreflector.

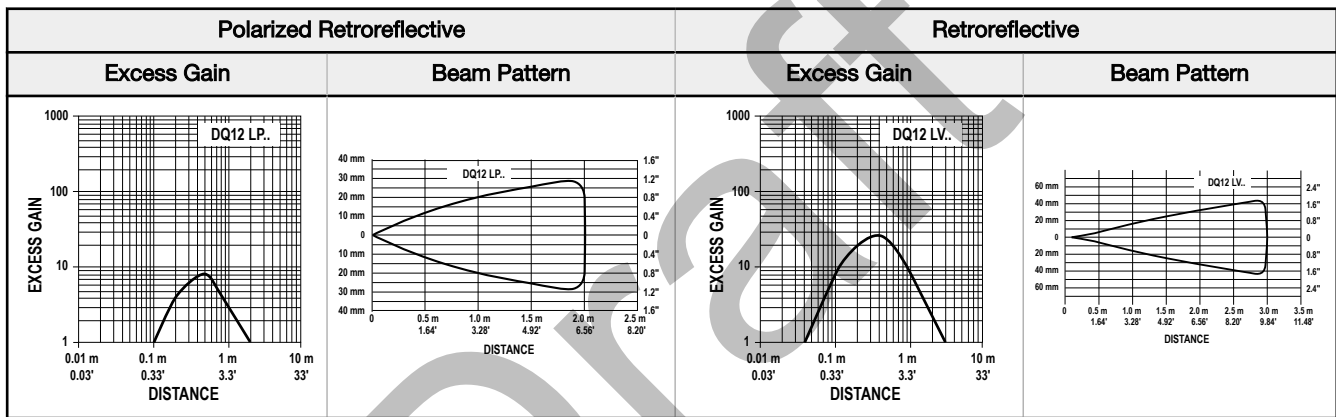

Fixed-field focus and spot sizes are typical. Performance based on use of 90% reflectance white test card.*

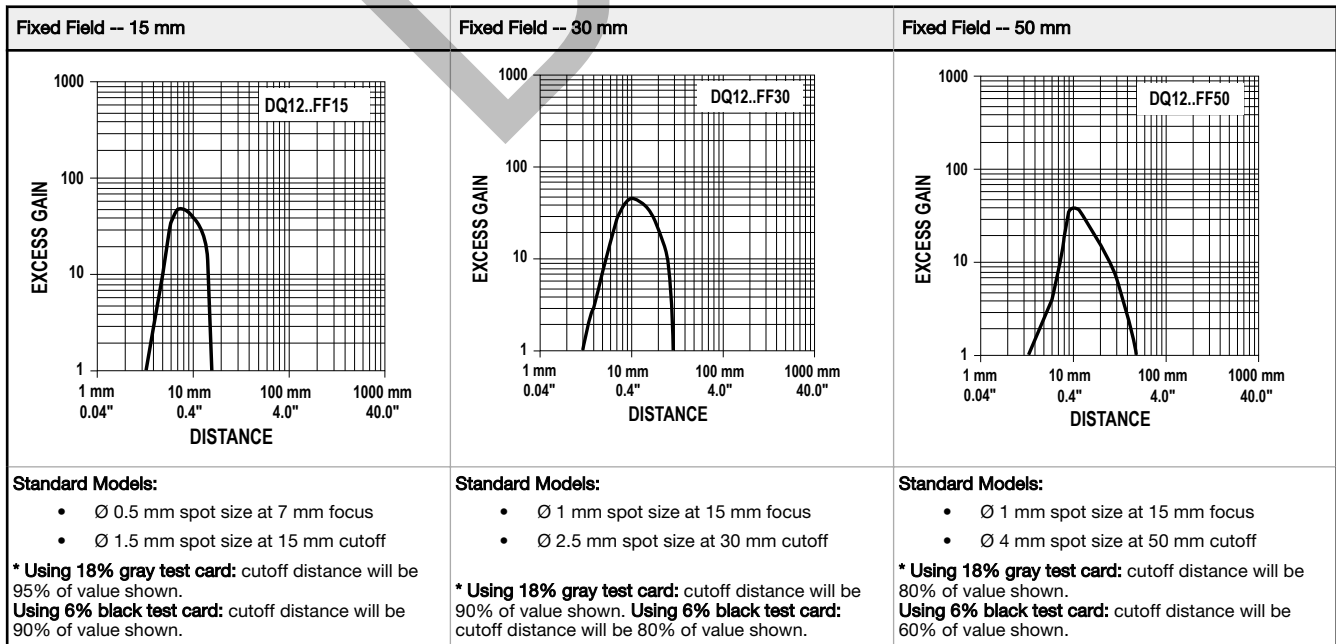

Accessories

Cordsets

3-Pin Threaded M8/Pico-Style Cordsets				
Model	Length	Style	Dimensions	Pinout (Female)
PKG3M-2	2.035 m (6.68 ft)	Straight		<p>1 = Brown 3 = Blue 4 = Black</p>
PKG3M-5	5.035 m (16.51 ft)			
PKG3M-7	7.035 m (23.08 ft)			
PKG3M-9	9.035 m (29.64 ft)			
PKG3M-10	10.035 m (32.92 ft)	Right-Angle		
PKW3M-2	2 m (6.56 ft)			
PKW3M-5	5 m (16.40 ft)			
PKW3M-9	9 m (29.53 ft)			

4-Pin Threaded M8/Pico-Style Cordsets—Single Ended				
Model	Length	Style	Dimensions	Pinout (Female)
PKG4M-2	2 m (6.56 ft)	Straight		<p>1 = Brown 2 = White 3 = Blue 4 = Black</p>
PKG4M-5	5 m (16.4 ft)			
PKG4M-9	9 m (29.5 ft)			
PKW4M-2	2 m (6.56 ft)	Right Angle		
PKW4M-5	5 m (16.4 ft)			
PKW4M-9	9 m (29.5 ft)			

4-Pin Threaded M12/Euro-Style Cordsets—Single Ended				
Model	Length	Style	Dimensions	Pinout (Female)
MQDC-406	1.83 m (6 ft)	Straight		<p>1 = Brown 2 = White 3 = Blue 4 = Black</p>
MQDC-415	4.57 m (15 ft)			
MQDC-430	9.14 m (30 ft)			
MQDC-450	15.2 m (50 ft)	Right-Angle		
MQDC-406RA	1.83 m (6 ft)			
MQDC-415RA	4.57 m (15 ft)			
MQDC-430RA	9.14 m (30 ft)			
MQDC-450RA	15.2 m (50 ft)			

Brackets

SMBQ12T

- Right-angle bracket
- 20-ga. 300 series stainless steel

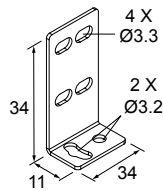

Hole center spacing: A to B = 7.6

Hole size: A = 3.5 x 8.1, B=ø 3.2

SMBQ12A

- Adjustable right-angle bracket
- 20-ga. 300 series stainless steel

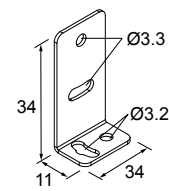

Hole center spacing: A to B = 7.6

Hole size: A = 3.5 x 8.1, B=ø 3.2

Apertures

Opposed-mode sensors (standard models only) may be fitted with apertures to narrow or shape the sensor's effective beam to more closely match the size or profile of the objects being sensed. A common example is the use of "line" (or "slot") type apertures to sense thread.



Note: The use of apertures will reduce the sensing range (see table below).

Model	Description	Pieces	Reduced Sensor Range (Two Apertures Used)
Circular			
APQ12-.5	0.5 mm (0.02 in) diameter	10	60 mm (2.4 in)
APQ12-1	1 mm (0.04 in) diameter	10	190 mm (7.5 in)
APQ12-1.5	1.5 mm (0.06 in) diameter	10	400 mm (15.7 in)
APQ12-2	2 mm (0.08 in) diameter	10	725 mm (28.5 in)
Horizontal Slot			
APQ12-.5H	0.5 mm (0.02 in)	10	350 mm (13.8 in)
APQ12-1H	1 mm (0.04 in)	10	725 mm (28.5 in)
Vertical Slot			
APQ12-.5V	0.5 mm (0.02 in)	10	450 mm (17.7 in)
APQ12-1V	1 mm (0.04 in)	10	900 mm (35.4 in)
Protective Jacket			
APQ12-4S	4 mm (0.16 in) square	10	2000 mm (78.7 in)
APKQ12	Kit containing two of each aperture above	18	—

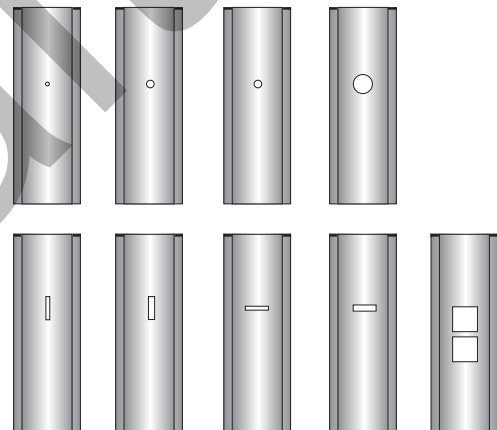

Banner Engineering Corp. Limited Warranty

Banner Engineering Corp. warrants its products to be free from defects in material and workmanship for one year following the date of shipment. Banner Engineering Corp. will repair or replace, free of charge, any product of its manufacture which, at the time it is returned to the factory, is found to have been defective during the warranty period. This warranty does not cover damage or liability for misuse, abuse, or the improper application or installation of the Banner product.

THIS LIMITED WARRANTY IS EXCLUSIVE AND IN LIEU OF ALL OTHER WARRANTIES WHETHER EXPRESS OR IMPLIED (INCLUDING, WITHOUT LIMITATION, ANY WARRANTY OF MERCHANTABILITY OR FITNESS FOR A PARTICULAR PURPOSE), AND WHETHER ARISING UNDER COURSE OF PERFORMANCE, COURSE OF DEALING OR TRADE USAGE.

This Warranty is exclusive and limited to repair or, at the discretion of Banner Engineering Corp., replacement. **IN NO EVENT SHALL BANNER ENGINEERING CORP. BE LIABLE TO BUYER OR ANY OTHER PERSON OR ENTITY FOR ANY EXTRA COSTS, EXPENSES, LOSSES, LOSS OF PROFITS, OR ANY INCIDENTAL, CONSEQUENTIAL OR SPECIAL DAMAGES RESULTING FROM ANY PRODUCT DEFECT OR FROM THE USE OR INABILITY TO USE THE PRODUCT, WHETHER ARISING IN CONTRACT OR WARRANTY, STATUTE, TORT, STRICT LIABILITY, NEGLIGENCE, OR OTHERWISE.**

Banner Engineering Corp. reserves the right to change, modify or improve the design of the product without assuming any obligations or liabilities relating to any product previously manufactured by Banner Engineering Corp. Any misuse, abuse, or improper application or installation of this product or use of the product for personal protection applications when the product is identified as not intended for such purposes will void the product warranty. Any modifications to this product without prior express approval by Banner Engineering Corp will void the product warranties. All specifications published in this document are subject to change; Banner reserves the right to modify product specifications or update documentation at any time. Specifications and product information in English supersede that which is provided in any other language. For the most recent version of any documentation, refer to: www.bannerengineering.com.

For patent information, see www.bannerengineering.com/patents.

FCC Part 15 and CAN ICES-3 (B)/NMB-3(B)

This device complies with part 15 of the FCC Rules and CAN ICES-3 (B)/NMB-3(B). Operation is subject to the following two conditions:

1. This device may not cause harmful interference, and
2. This device must accept any interference received, including interference that may cause undesired operation.

This equipment has been tested and found to comply with the limits for a Class B digital device, pursuant to part 15 of the FCC Rules and CAN ICES-3 (B)/NMB-3(B). These limits are designed to provide reasonable protection against harmful interference in a residential installation. This equipment generates, uses and can radiate radio frequency energy and, if not installed and used in accordance with the instructions, may cause harmful interference to radio communications. However, there is no guarantee that interference will not occur in a particular installation. If this equipment does cause harmful interference to radio or television reception, which can be determined by turning the equipment off and on, the user is encouraged to try to correct the interference by one or more of the following measures:

- Reorient or relocate the receiving antenna.
- Increase the separation between the equipment and receiver.
- Connect the equipment into an outlet on a circuit different from that to which the receiver is connected.
- Consult the manufacturer.

Draft