

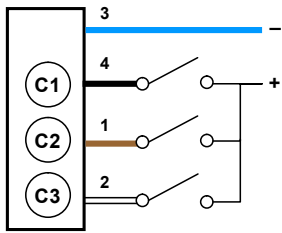

## Wiring Diagram



### Wiring Key

- 1 = Brown
- 2 = White
- 3 = Blue
- 4 = Black

### Color Key

- C1 = Color 1
- C2 = Color 2
- C3 = Color 3

### Pinout

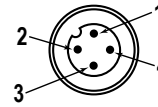

See Configuration section for hazardous area wiring and installation notes.

## Configuration

### One Color Configuration

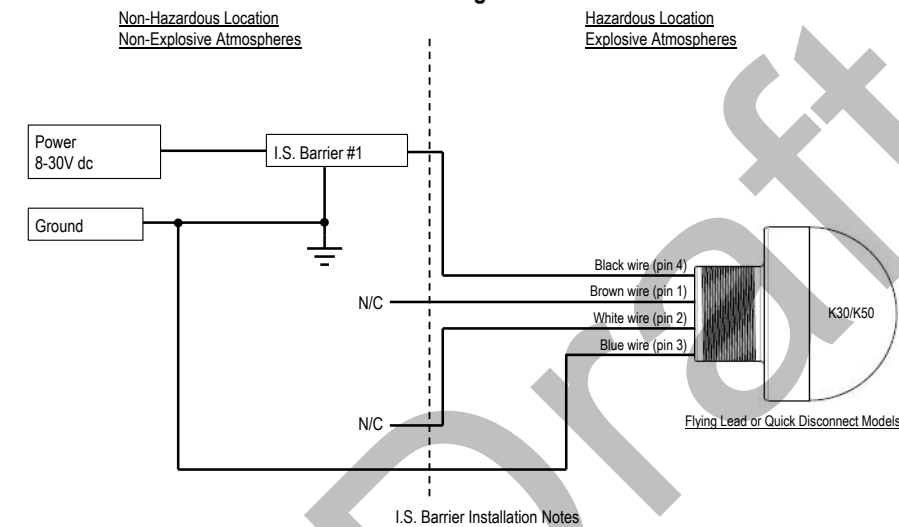

### I.S. Barrier Installation Notes

1. Safety parameters are as follows:  
 $U_i / V_{max} = 30V$   
 $I_i / I_{max} = 1A$   
 $P_i = 3.4W$  ( $T_a = -40^\circ C$  to  $+40^\circ C$ )  
 $P_i = 2.8W$  ( $T_a = -40^\circ C$  to  $+50^\circ C$ )  
 $C_i = 0$   
 $L_i = 0$

2. Choose approved barriers such that the following conditions are met with all barriers combined  
 $U_i / V_{max} \geq U_o / V_{oc}$   
 $I_i / I_{max} \geq I_o / I_{sc}$   
 $P_i / P_{max} \geq P_o$   
 $C_o / C_a \geq C_i + C_{cable}$   
 $L_o / L_a \geq L_i + L_{cable}$

3. Install I.S. barriers in accordance with manufacturers instructions and local codes

4. Suggested I.S. barriers are as follows  
 MTL 7715+ (15V/100 $\Omega$ )  
 MTL 7715P+ (15V/50  $\Omega$ )  
 Turck MZB15PX (15V/50  $\Omega$ )

	IIC	IIB	IIA
C <sub>cable</sub>	66nF	0.56 $\mu$ F	1.82 $\mu$ F
L <sub>cable</sub>	35 $\mu$ H	140 $\mu$ H	280 $\mu$ H

Figure 1. Control Drawing 1-Color Configuration

### Two Color Configuration

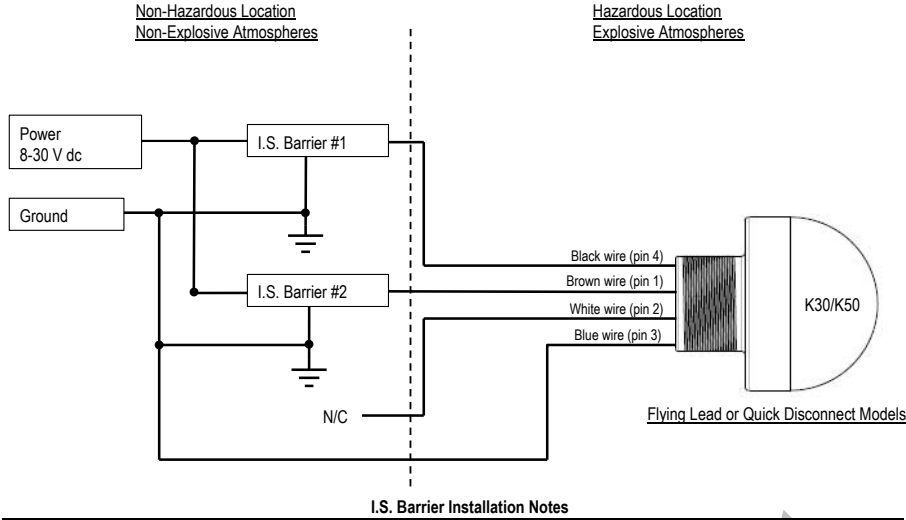

#### I.S. Barrier Installation Notes

- Safety Parameters are as follows:  
 $U_i / V_{max} = 30V$   
 $I_i / I_{max} = 1A$   
 $P_i = 3.4W$  ( $T_a = -40^\circ C$  to  $+40^\circ C$ )  
 $P_i = 2.8W$  ( $T_a = -40^\circ C$  to  $+50^\circ C$ )  
 $C_i = 0$   
 $L_i = 0$

- Choose approved barriers such that the following conditions are met with all barriers combined  
 $U_i / V_{max} \geq U_o / V_{oc}$   
 $I_i / I_{max} \geq I_o / I_{sc}$   
 $P_i / P_{max} \geq P_o$   
 $C_o / C_a \geq C_i + C_{cable}$   
 $L_o / L_a \geq L_i + L_{cable}$

- Install I.S. barriers in accordance with manufacturers instructions and local codes

	IIC	IIB	IIA
C <sub>cable</sub>	66nF	0.56µF	1.82µF
L <sub>cable</sub>	35µH	140µH	280µH

Figure 2. Control Drawing 2-Color Configuration

### Three Color Configuration

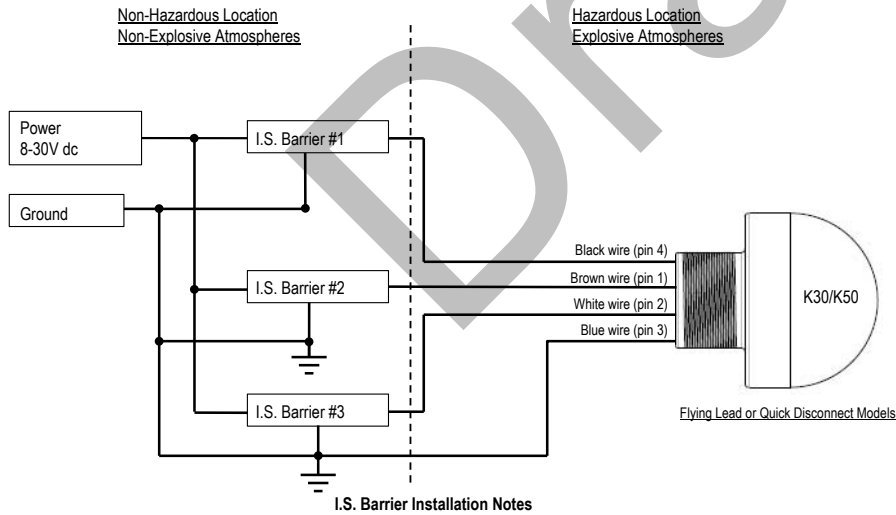

#### I.S. Barrier Installation Notes

- Safety Parameters are as follows:  
 $U_i / V_{max} = 30V$   
 $I_i / I_{max} = 1A$   
 $P_i = 3.4W$  ( $T_a = -40^\circ C$  to  $+40^\circ C$ )  
 $P_i = 2.8W$  ( $T_a = -40^\circ C$  to  $+50^\circ C$ )  
 $C_i = 0$   
 $L_i = 0$

- Choose approved barriers such that the following conditions are met with all barriers combined  
 $U_i / V_{max} \geq U_o / V_{oc}$   
 $I_i / I_{max} \geq I_o / I_{sc}$   
 $P_i / P_{max} \geq P_o$   
 $C_o / C_a \geq C_i + C_{cable}$   
 $L_o / L_a \geq L_i + L_{cable}$

- Install I.S. barriers in accordance with manufacturers instructions and local codes

- Suggested I.S. barriers are as follows  
 MTL 7715+ (15V/100Ω)  
 MTL 7715P+ (15V/50 Ω)  
 Turck MZB15PX (15V/50 Ω)

	IIC	IIB	IIA
C <sub>cable</sub>	66nF	0.56µF	1.82µF
L <sub>cable</sub>	35µH	140µH	280µH

Figure 3. Control Drawing 3-Color Configuration

## General Notes and Conditions for Safe Use

- The dust rating of enclosures/panels may be invalidated by the installation of the EZ-LIGHT(s). The installation of the EZ-LIGHT(s) in a particular enclosure/panel is subject to the evaluation/acceptance of the applicable approval agency.

2. The user has the responsibility to ensure that all local, state, and national laws, rules, codes, or regulations relating to the installation and use of this Banner device in any particular application are satisfied. This Banner device must be installed by Qualified Persons<sup>2</sup>, in accordance with this document and applicable regulations.
3. Do not attempt any repairs to this Banner device; it contains no field-replaceable parts or components.
4. The nonconducting materials of this device may be susceptible to ignition-capable level of electrostatic charging and precautions must be taken to avoid this. The user/installer shall ensure that the equipment is not installed in a location where it may be subjected to external conditions (such as high-pressure steam) which are conducive to creating a build-up of electrostatic charges.
5. If the equipment is likely to come into contact with aggressive substances<sup>3</sup>, then it is the responsibility of the user to take suitable precautions<sup>4</sup> that prevent it from being adversely affected, thus ensuring that the type of protection is not compromised.
6. Clean with a damp cloth only.
7. For indicators with multiple colors, only one color is intended to be on at a time.
8. When more than one intrinsically safe supply (e.g. two or three barriers) is connected to an LED indicator (input) the combined electrical parameters of the supply must remain intrinsically safe.

## Specifications

### Supply Voltage and Current

See Configuration for safety parameters

### Indicators

Entire translucent diffuser or dome provides indication. LEDs are independently selected: Green, Red, or Amber; 2 or 3 colors, depending on model. For other colors/combinations, contact Banner Engineering for availability.

### Environmental Rating

IEC IP67/IEC IP69K

### Approvals

#### CSA-c/us

Gas and Vapors: Class I Zone 0 AEx/Ex ia IIC T4 Ga / Class I Div 1 Groups ABCD  
 Dust: Class II Zone 20 AEx/Ex ia IIIC T130°C Da / Class II Div 1 Groups EFG,  
 Class III Div 1  
 CSA 14.2679646

#### ATEX/IECEx

Gas and Vapors: II 1 G Ex ia IIC T4 Ga (Group IIC Zone 0)  
 Dust: II 1 D Ex ia IIIC T130°C Da (Group IIIC Zone 20)  
 Mines: I M1 Ex ia I Ma (Methane)  
 Sira 13ATEX2058X  
 IECEx Sir 13.0020X

### Construction

Base: polycarbonate  
 Translucent dome: polycarbonate

### Connections

Maximum cable length 29 m per parameters list in [Figure 1](#) on p. 2, [Figure 2](#) on p. 3, and [Figure 3](#) on p. 3.

**K30:** 2 m (6.5 ft) PVC integral cable, or 150 mm (5.9 in) PVC cable with 4-pin M12/Euro quick disconnect

**K50:** 4-pin M12/Euro integral quick disconnect, 2 m (6.5 ft) PVC integral cable, or 150 mm (5.9 in) PVC cable with 4-pin M12/Euro quick disconnect

### Operating Conditions

Pi = 2.8W: Ta = -40 °C to +50 °C (-40 °F to +122 °F)

Pi = 3.4W: Ta = -40 °C to +40 °C (-40 °F to +104 °F)

See figures 1, 2, and 3

### Certifications



IEC IECEx SIR 13.0020X

ATEX Sira 13ATEX2058X

CSA CoC 2679646

<sup>2</sup> A person who, by possession of a recognized degree or certification of professional training, or who, by extensive knowledge, training and experience, has successfully demonstrated the ability to solve problems relating to the subject matter and work.

<sup>3</sup> Aggressive substances—for example, acidic liquids or gases that may attack metals, or solvents that may affect polymeric materials.

<sup>4</sup> Suitable precaution—for example, regular checks as part of routine inspections or establishing from the materials data sheet that it is resistant to specific chemicals.

## Dimensions

### K30L Cabled Models

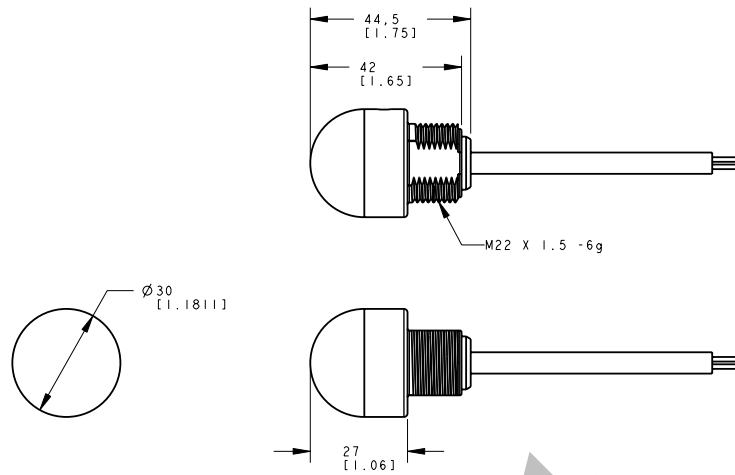

### K50L Quick Disconnect Models

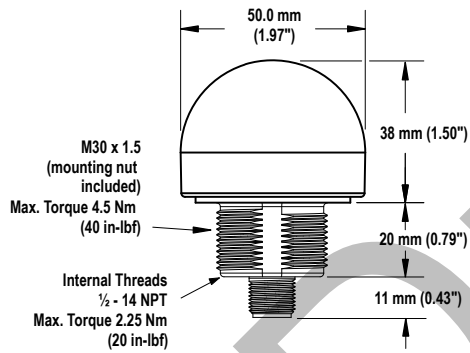

### K50L Cabled Models

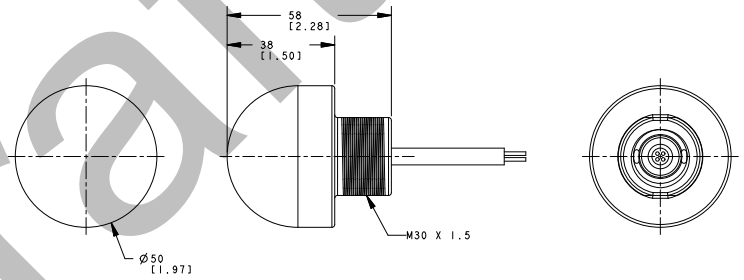

## Accessories

### Cordsets

4-Pin Threaded M12/Euro-Style Cordsets—Single Ended				
Model	Length	Style	Dimensions	Pinout (Female)
MQDC-406	2 m (6.56 ft)	Straight		
MQDC-415	5 m (16.4 ft)			
MQDC-430	9 m (29.5 ft)			
MQDC-450	15 m (49.2 ft)			

1 = Brown  
2 = White  
3 = Blue  
4 = Black

4-Pin Threaded M12/Euro-Style Cordsets—Single Ended				
Model	Length	Style	Dimensions	Pinout (Female)
MQDC-406RA	2 m (6.56 ft)	Right-Angle		
MQDC-415RA	5 m (16.4 ft)			
MQDC-430RA	9 m (29.5 ft)			
MQDC-450RA	15 m (49.2 ft)			

## Banner Engineering Corp. Limited Warranty

Banner Engineering Corp. warrants its products to be free from defects in material and workmanship for one year following the date of shipment. Banner Engineering Corp. will repair or replace, free of charge, any product of its manufacture which, at the time it is returned to the factory, is found to have been defective during the warranty period. This warranty does not cover damage or liability for misuse, abuse, or the improper application or installation of the Banner product.

**THIS LIMITED WARRANTY IS EXCLUSIVE AND IN LIEU OF ALL OTHER WARRANTIES WHETHER EXPRESS OR IMPLIED (INCLUDING, WITHOUT LIMITATION, ANY WARRANTY OF MERCHANTABILITY OR FITNESS FOR A PARTICULAR PURPOSE), AND WHETHER ARISING UNDER COURSE OF PERFORMANCE, COURSE OF DEALING OR TRADE USAGE.**

This Warranty is exclusive and limited to repair or, at the discretion of Banner Engineering Corp., replacement. **IN NO EVENT SHALL BANNER ENGINEERING CORP. BE LIABLE TO BUYER OR ANY OTHER PERSON OR ENTITY FOR ANY EXTRA COSTS, EXPENSES, LOSSES, LOSS OF PROFITS, OR ANY INCIDENTAL, CONSEQUENTIAL OR SPECIAL DAMAGES RESULTING FROM ANY PRODUCT DEFECT OR FROM THE USE OR INABILITY TO USE THE PRODUCT, WHETHER ARISING IN CONTRACT OR WARRANTY, STATUTE, TORT, STRICT LIABILITY, NEGLIGENCE, OR OTHERWISE.**

Banner Engineering Corp. reserves the right to change, modify or improve the design of the product without assuming any obligations or liabilities relating to any product previously manufactured by Banner Engineering Corp. Any misuse, abuse, or improper application or installation of this product or use of the product for personal protection applications when the product is identified as not intended for such purposes will void the product warranty. Any modifications to this product without prior express approval by Banner Engineering Corp will void the product warranties. All specifications published in this document are subject to change; Banner reserves the right to modify product specifications or update documentation at any time. Specifications and product information in English supersede that which is provided in any other language. For the most recent version of any documentation, refer to: [www.bannerengineering.com](http://www.bannerengineering.com).

For patent information, see [www.bannerengineering.com/patents](http://www.bannerengineering.com/patents).



more sensors, more solutions