

EZ-SCREEN™ Safety Light Screen (Stand-Alone)

System Daily Checkout Procedure – Non-Cascaded Systems



To Be Performed at Every Power-up, Shift Change, and Machine Setup:

Daily checkout and checkouts after tooling and machine changes must be performed by a Designated Person (appointed and identified in writing by the employer). During continuous machine run periods, this checkout must be performed at regular intervals. A copy of the checkout results should be kept on or near the machine: see OSHA 1910.217(e)(1).

✓ **The Designated Person must:**

1) **Verify that:**

- Access to the guarded area is not possible from any area not protected by the EZ-SCREEN System. Hard guarding or supplemental presence-sensing devices must be installed, wherever needed, to prevent any person from reaching over, under or around the defined area or entering into the hazard area.
- All supplemental guarding devices and hard guarding are in place and operating properly.

2) **Verify that the minimum separation distance** from the closest hazard point of the guarded machine to the defined area is not less than the separation distance calculated in Section 3.1.1 of the instruction manual and recorded here: _____.

3) **Verify that:**

- **It is not possible for a person to stand inside the guarded (dangerous) area, undetected by the EZ-SCREEN System or other supplemental guarding (as described in ANSI/RIA R15.06, or other appropriate standards).**

4) **Verify that:**

- The Reset switch is mounted outside the guarded area, out of reach of anyone inside the guarded area and
- The means of preventing inadvertent use (e.g., rings or guards) is in place.

NOTE: For cascaded, multiple-pair EZ-SCREEN systems, refer to Daily Checkout card P/N 118173.

5) **Once all Zone indicators are steady Green, test the effectiveness of the EZ-SCREEN System with power ON**, using the trip test. Select the appropriate piece:

	RR OFF	RR Enabled
14 mm Models	STP-13	STP-14
30 mm Models	STP-14	STP-15

5a) **Trip Test (Stand-Alone Systems)**

With power ON, verify that the EZ-SCREEN System is in RUN mode; receiver status indicators should be as follows:

Status Indicator	ON Green or Flashing
All Zone Indicators	ON Green
Reset Indicator	ON Yellow
Diagnostic Display	"—" (Trip Output mode) or "L" (Latch Output Mode)

A manual reset may be required in Latch Output mode (see manual, Sections 4.2 and 4.3).

5b) **With the guarded machine at rest, pass the test piece downward through the defined area in three paths:** near the receiver, near the emitter, and midway between them (Figure 1).

- *If the emitter and receiver are far apart*, a second person may be needed to monitor the indicators while the test piece is used near the emitter or in the midway position.
- *If corner mirrors are used in the application*, the beams must be tested in three places on each leg of the beam path (between emitter and mirror, and also between mirror and receiver, Figure 2).

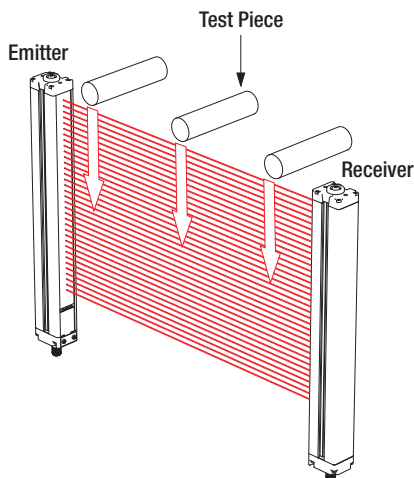

Figure 1. EZ-SCREEN System trip test

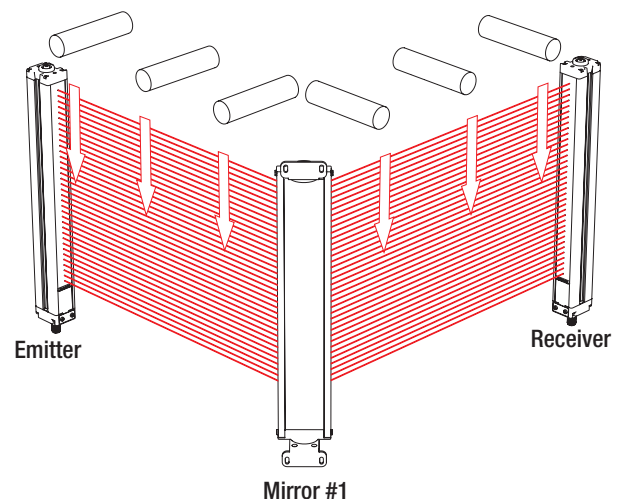

Figure 2. EZ-SCREEN System trip test for corner mirror applications

EZ-SCREEN™ Safety Light Screen – Stand-Alone Daily Checkout

5c) Verify whenever the test piece is interrupting the defined area:

At least one Zone indicator must be steady Red. The particular Red Zone indicator(s) lit will change, according to the position of the test piece.

NOTE: If beam 1 is blocked, Zone 1 indicator will be Red and all other Zone indicators will be OFF, because beam 1 provides the synchronization signal for all the beams. The display will indicate “CH1”.

- **Trip Output Operation** – The Status indicator must turn Red and remain Red while the test piece remains in the defined area. If not, the installation has failed the trip test.
- **Latch Output Operation** – The Status indicator must turn Red and remain Red, and the Yellow Reset indicator must remain ON steady while the test piece remains in the defined area. If the Reset indicator begins to flash at any time while the test piece is interrupting the defined area, the installation has failed the trip test.

If all Zone indicators are Green or do not follow the position of the test piece, or if the Status indicator turns Green while the test piece is interrupting the defined area, the installation has failed the trip test.

Check for correct sensor orientation, for the presence of reflective surfaces (see below), or for unguarded areas created by the use of blanking.

Do not continue with this checkout procedure or operate the guarded machine until the situation is corrected and the indicators respond properly as described above.

5d) Verify when the test piece is removed from the defined area:

- All Zone indicators turn steady Green.
- If the System is operating in Latch Output mode, the Yellow Reset indicator should be flashing. Perform a manual reset.
- Verify that the receiver Status indicator is steady Green (or flashing Green if Reduced Resolution is enabled).

Eliminating Problems with Reflective Surfaces

- **If possible, relocate the emitter and/or receiver** to move the defined area away from the reflective surface(s), being careful to maintain adequate separation distance (see step 2).
- **Otherwise, if possible, paint, mask or roughen the surface** to reduce the reflectivity.
- **Where these are not possible (as with a shiny workpiece)**, include a means of restricting the receiver's field of view or the emitter's spread of light in the sensor mounting.
- **Repeat the trip test** to verify that these changes have eliminated the problem reflection(s). If the workpiece is especially reflective and comes close to the defined area, perform the trip test with the workpiece in place.

 **WARNING . . . If Trip Test Indicates a Problem**
If the EZ-SCREEN System does not respond properly to the trip test, do not attempt to use the System. If this occurs, the System cannot be relied upon to stop dangerous machine motion when a person or object enters the defined area. Serious bodily injury or death could result.

 **WARNING . . . Before Applying Power to the Machine**
Verify that the guarded area is clear of personnel and unwanted materials (such as tools) before applying power to the guarded machine. Failure to do so could result in serious bodily injury or death.

- 6) **Initiate machine motion of the guarded machine**, and while it is moving, insert the supplied test piece into the defined area. **Do not attempt to insert the test piece into the dangerous parts of the machine.**

Verify that, whenever the test piece is in the defined area:

- **The dangerous parts of the machine** come to a stop with no apparent delay.

Remove the test piece from the defined area, and verify that:

- **The machine** does not automatically restart, and
- **Initiation devices** must be engaged to restart the machine.

- 7) **With the guarded machine at rest, insert the test piece into the defined area and verify:**

- The guarded machine cannot be put into motion while the test piece is in the defined area.

- 8) **Check carefully for external signs of damage or changes** to the EZ-SCREEN System, the guarded machine, and their electrical wiring. Any damage or changes found should be immediately reported to management.

Do not continue operation until the entire checkout procedure is complete and all problems are corrected.

 **WARNING . . . Do Not Use Machine Until System Is Working Properly**
If all of these checks cannot be verified, do not attempt to use the EZ-SCREEN System/guarded machine until the defect or problem has been corrected (see Section 5 of the manual).
Attempts to use the guarded machine under such conditions could result in serious bodily injury or death.