

MULTI-BEAM Fiber Optic Scanner Block

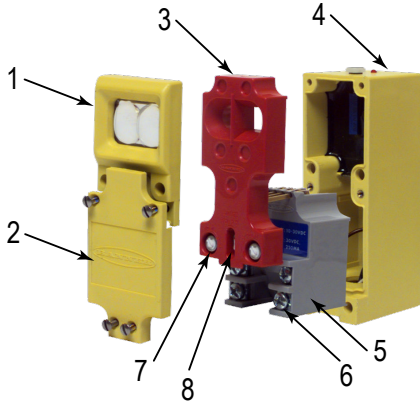

Datasheet

3- and 4-Wire Fiber Optic Mode Scanner Blocks for MULTI-BEAM Modular Photoelectric Sensors



- 1 = Upper cover (lens), supplied with the scanner block
- 2 = Lower cover, supplied with the scanner block
- 3 = Logic module
- 4 = Scanner block housing
- 5 = Power block
- 6 = Wiring terminals
- 7 = Logic timing adjustment
- 8 = Light/Dark operate select

A scanner block consists of a scanner block housing, an upper cover assembly, and a lower cover. Other modular components (logic module and power block module) are purchased separately.



WARNING: Not To Be Used for Personnel Protection

Never use this device as a sensing device for personnel protection. Doing so could lead to serious injury or death. This device does not include the self-checking redundant circuitry necessary to allow its use in personnel safety applications. A sensor failure or malfunction can cause either an energized or de-energized sensor output condition.

Fiber optic mode MULTI-BEAMS are used with Banner's extensive selection of glass fiber optics to allow sensing in areas too "tight" or otherwise too environmentally hostile to the scanner block itself. In addition, the fiber bundle of a glass fiber optic assembly may be shaped at the sensing tip to exactly match the profile of the object to be sensed.

The Banner product catalog contains complete descriptions of all standard glass fiber optic models, as well as examples of special custom fiber optic designs. Banner welcomes your special fiberoptic sensing application requirements.

The fiber optic gain curves printed in this datasheet apply to 3-foot lengths. Excess gain decreases by approximately 10% for each additional foot of fiber optic cable.

Models

SBEF and SBRF1: Use with individual glass fiber optic assemblies in lieu of model SBF1 where it is inconvenient to run fibers from a single scanner block.

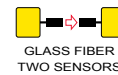

SBEXF and SBRXF1: Use in place of model SBFX1 for long-range opposed fiber optic sensing. Or use where high excess gain is required and it is difficult to run the fibers to both sides of the process from a single scanner block.

| Models | Response Time | Beam |
|-----------------|---------------|--------------------------------------|
| SBEF Emitter | 1 ms | Opposed Mode Pairs, Infrared, 880 nm |
| SBRF1 Receiver | | |
| SBEXF Emitter | 10 ms | |
| SBRXF1 Receiver | | |



SBFX1 is the first choice for glass fiber optic applications, except in fiber optic retroreflective applications or where faster response speed or visible light area a requirement. Model SBFX1 contains both emitter and receiver and thus accepts either one bifurcated fiber optic assembly or two individual fiber optic cables. The excess gain of model SBFX1 is the high available in the photoelectric industry. As a result, opposed individual fibers operate reliably in many very hostile environments. Also, special miniature bifurcated fiber optic assemblies with bundle sizes as small as 0.020 inches (0.5 mm) in diameter may be used successfully with model SBFX1 for diffuse mode sensing. The excess gain curves and beam patterns illustrate response with standard 0.060 inch (1.5 mm) diameter and 0.12 inch (3 mm) diameter bundles. Response for smaller or larger bundle sizes may be interpolated. Note: Opposed range shown are meant to illustrate excess gain only and are limited by fiber length. Use scanner block models SBEXF and SBRXF1 for long-range opposed fiber optic sensing.

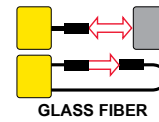

| Models | Response Time | Beam |
|--------|---------------|-------------------------------------------|
| SBFX1 | 10 ms | Opposed or Diffuse Mode, Infrared, 880 nm |

SBFV1 Visible Red Light Source supplies visible red light to the emitter half of a glass fiber optic photoelectric system. Visible light sensors have less optical energy compared to infrared systems. There are, however, some sensing situations that require visible light wavelengths to realize adequate optical contrast.

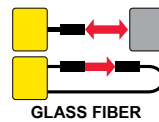

Opposed fibers using visible red light are used to reliably sense translucent materials (plastic bottles) that appear transparent to infrared opposed sensors. Fiber assembly model BT13S used with a model L9 or L16F lens makes an excellent visible light sensing system for retroreflective code reading as well as for many short-range retroreflective applications, such as retro sensing across a narrow conveyor.

When combined with a bifurcated fiber, model SBFV1 may be used for color registration sensing for applications where there is a large difference between the two colors, for example, black on white. For combinations of red on white, however, the visible green light source of model SBFVG1 is needed. Visible light emitters are also helpful for visual system alignment and maintenance.

| Models | Response Time | Beam |
|--------|---------------|----------------------------------------------------------------|
| SBFV1 | 1 ms | Opposed, Retroreflective, or Diffuse Mode, Visible Red, 650 nm |

SBFVG1 Visible Green Light Source for Color Sensing (Registration Control). Convergent beam sensors like model SBCVG1 are often used for color registration sensing. However, there are some registration applications where the use of bifurcated fiber optics is beneficial. Fiber optics are able to fit into tight locations that are too small for a convergent sensor.

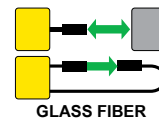

Fibers also allow a choice of image size. It is important to create an image size that is smaller than the registration mark to maximize optical contrast and to ease sensor response requirements. Fibers allow a match of the light image to the geometry of the registration mark. Scanner block model SBFVG1 will sense most bold color differences, including red on white. Use only power blocks that switch dc (for example, PBT, PBP, PBO, and PBAT) for fast response.

| Models | Response Time | Beam |
|--------|---------------|-------------------------------------|
| SBFVG1 | 1 ms | Diffuse Mode, Visible Green, 560 nm |

SBF1 High Speed Scanner Block. Fiber optics are often used to sense small parts. Small parts or narrow profiles that move at a high rate of speed can require sensors with fast response times for reliable detection. High-speed fiber optics sensors are ideal for sensing gear or sprocket teeth or other targets in applications involving counters or shift registers for position control.

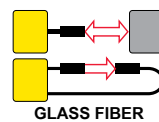

Selection of the fiber optic sensing tip should involve matching the effective beam of the fiber to the profile of the part to be sensed to maximize the time that the part is sensed and/or the time between adjacent parts. Combining the best selection of fiber tip geometry with a high speed sensor will result in a highly repeatable position sensing system.

The model BT13S fiber optic assembly used with a model L9 or L16F lens and a high speed scanner block is an excellent system for retroreflective code reading or for almost any short range retroreflective sensing application. Response time of a MULTI-BEAM sensor is also a function of the power block. For this reason, use only power blocks that switch DC (PBT, PBP, PBO, PBAT, etc) to take advantage of the scanner block's fast response time.

| Models | Response Time | Beam |
|--------|---------------|-------------------------------------------------------------|
| SBF1 | 1 ms | Opposed, Retroreflective, or Diffuse Mode, Infrared, 940 nm |

SBF1MHS Very High Speed Scanner Block is the model SBF1 modified for high-speed (300 μ s) response. It may be used in either fiber optic opposed or fiber optic diffuse mode. Note that the faster response comes at the expense of lower gain (see excess gain curves for both models and MHS modification note).

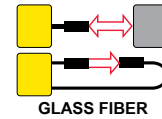

| Models | Response Time | Beam |
|---------|---------------|-------------------------------------------|
| SBF1MHS | 300 μ s | Opposed or Diffuse Mode, Infrared, 940 nm |

MULTI-BEAM Scanner Block Modifications

The following are popular modifications to MULTI-BEAM 3- and 4-wire scanner blocks. They are not stocked, but are available on a quote basis.

Zero Hysteresis Modification "MZ". Amplifier hysteresis may be removed from 3- and 4-wire scanner blocks when attempting to sense very small signal changes (contrasts less than 3). This modification is designated by adding suffix "MZ" (modified zero hysteresis). Verify all variables affecting the sensor's optical response remain constant before ordering the zero hysteresis modification.

High Speed Modification "MHS". Scanner blocks with 1 millisecond response may be modified for 300 microsecond (0.3 ms) response. This modification is designated by adding suffix "MHS" to the scanner block model number (for example, SBF1MHS). The MHS modification reduces the available excess gain by about 50% and also decreases the sensor's immunity to some forms of electrical noise.

Overview

A Banner MULTI-BEAM sensor is a compact modular self-contained photoelectric switch consisting of three components: a scanner block, a power block, and a logic module.

The scanner block, described in this datasheet, comprises the housing for the sensor and contains a complete modulated photoelectric amplifier, the emitter and/or received optoelements, and space for the other modules.

The power block module provides the interface between the scanner block and the external circuit. It contains a power supply for the MULTI-BEAM plus a switching device to interface the sensor to the circuit to be controlled. Three- and four-wire dc power block modules operate from dc voltages and are discussed in datasheet 03499. Three- and four-wire ac power blocks operate from ac voltages and are covered in datasheet 03501.

The logic module (datasheet 03304) interconnects the power block and scanner block both electrically and mechanically. It provides the desired timing logic function (if any) plus the ability to program the output for either light- or dark-operate.

Power block and logic modules are purchased separately. This modular design, with field-replaceable power block and logic modules, permits a large variety of sensor configurations, resulting in exactly the right sensor for any fiber optic photoelectric application.

MULTI-BEAM 3- and 4-wire fiber optic mode scanner blocks include several different standard models. The high power models (those with 10 millisecond response time) offer the greatest optical sensing power of any industrial fiber optic sensors.

The circuitry of all MULTI-BEAM components is encapsulated within rugged, corrosion-resistant VALOX® housings that meet or exceed NEMA 1, 3, 12, and 13 ratings. MULTI-BEAM 3- and 4-wire fiber optic mode scanner blocks include Banner's exclusive, patented¹, Alignment Indicating Device (AID™) system, which lights a top-mounted LED when the sensors sees its modulated light source and pulses at a rate proportional to the strength of the received light signal.

All MULTI-BEAM scanner blocks are totally solid-state for unlimited life.

¹ U.S. patent 4356393

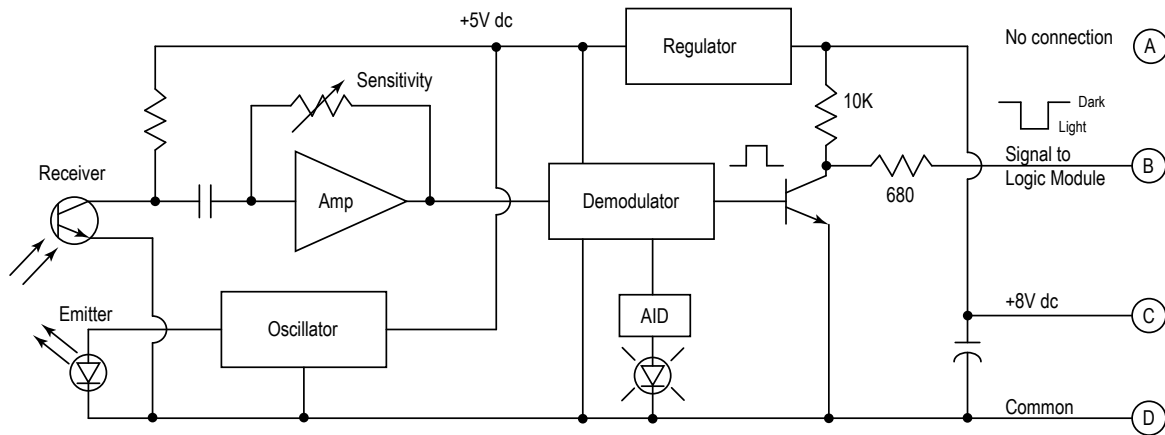

Figure 1. Functional Schematic

Banner's Alignment Indicating Device (AID™) System

Banner's Alignment Indicating Device (AID) system² is an exclusive built-in feature that permits optimum alignment and continuous monitoring of the photoelectric system. The red receiver LED indicator is on when the receiver sees the modulated light from the emitter and is off when the beam is broken. In addition, a low frequency pulse rate is superimposed on the LED indicator. When alignment is marginal, the pulse rate will be about once per second (indicating an excess gain of 1). As alignment is improved, the pulse rate increases, indicating increased excess gain. Optimum sensor alignment is indicated by the fastest pulse rate.

The AID feature also tells you when maintenance is necessary. Any pulse rate less than two per second indicates marginal performance; the unit, however, is still functioning properly. When the pulse rate slows to less than two per second, clean the lenses and check the alignment.

Attaching the Lens Assembly

Lenses are sometimes added to fiber optic assemblies for extending opposed sensing range or for retroreflective mode sensing.

Lenses are most efficient when they are located slightly beyond their focal length distance from the sensing end of the fiber optic bundle. The easiest way of focusing a lens is to treat it like a magnifying glass.

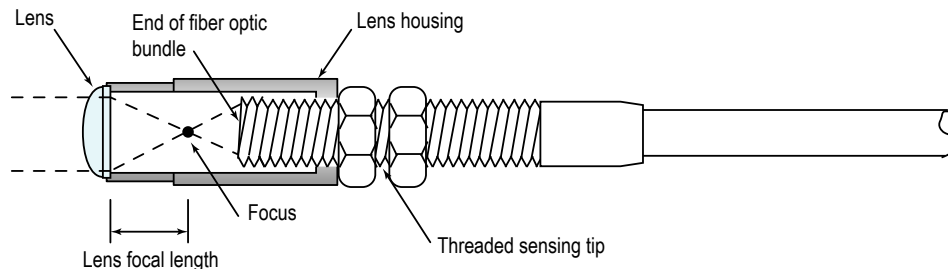

1. Illuminate the bundle at the threaded end of the fiber optic assembly by holding the opposite end toward a visible light source.
2. Thread the lens assembly onto the fiber optic assembly until the end of the fiber optic bundle comes into sharp focus under the lens.
3. Unthread the lens assembly from the point of the sharpest focus by one to three full turns. The illuminated bundle should now appear slightly blurred.

Aligning the Sensors

- The Alignment Indicating Device (AID™) LED on the top of the sensor is used in the following alignment procedures.

² U.S. Patent 4356393

- Apply power to the MULTI-BEAM power block at terminals 1 and 2, as shown in the hookup diagrams packed with the power block.
- The sensitivity control, located beneath the nylon cover screw at the top of the scanner block, is a 15-turn potentiometer, clutched at both ends. Use a small, flat-blade screwdriver to adjust the potentiometer.

Aligning Opposed Mode Sensors

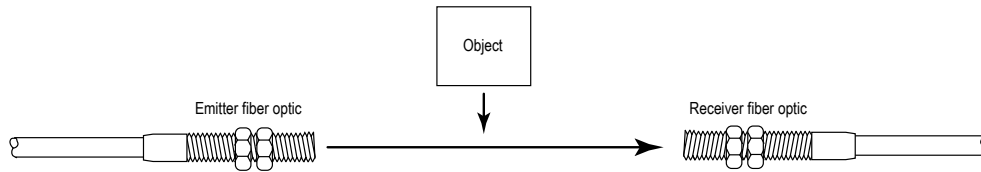

1. To align two individual fiber optic assemblies for opposed mode sensing, begin with one sensing tip mounted firmly in place.
2. Move the opposite fiber to find the position where the Alignment Indicating Device LED is pulsing at the fastest rate. Include angular movement during alignment.
3. Find the center of the area of movement where the LED is solidly on, or reduce the sensitivity (counter-clockwise rotation of the sensitivity control) to obtain a countable pulse rate.
4. Secure the fiber optic sensing tip in the optimum position.

Unlensed fiber optics are easier to align. Opposed fiber optics with large bundles, for example 1/8-inch diameter, usually require only line-of-sight alignment when used at opposed distances up to a few inches. Alignment requires more positioning accuracy when a lens is added on one side of the process. The requirement for alignment accuracy is even greater when lenses are used on both fiber assemblies.

To align fiber optic assemblies when lenses are installed:

1. Increase the sensitivity of the scanner block to maximum by rotating the sensitivity control 15 or more turns, clockwise.
2. Place the object to be detected in the center of the beam at the sensing location.
3. If the alignment indicator LED goes "off," alignment is complete.
4. Check the operation by alternately removing and replacing the object. The LED should follow the action by coming on when the object is absent and going off when the object is present.

If the alignment indicator stays on when the object is present at the sensing position, the cause may be one of the following:

- Small parts. The width of the object in the beam must be greater than the diameter of the fiber bundles or lenses. If the effective beam is too large to sense the object, consider using smaller fiber bundle diameters or substitute fiber optic assemblies with rectangular bundle terminations. Verify small parts are accurately placed in the center of the beam at the time they are to be detected.
- Transparent materials. Thin-walled and transparent materials may pass some of the light energy. In fact, some thin-walled plastics that appear opaque may easily pass infrared light. With the part in place, reduce the sensitivity (counter-clockwise rotation of the sensitivity control) until the alignment LED goes off, plus two more full turns. Remove the object and verify the Alignment Indicating Device LED is solid or pulsing faster than two beats per second. If this adjustment fails, consider sensing the object by diffuse mode or by another sensing scheme.

Aligning Diffuse Mode Sensors

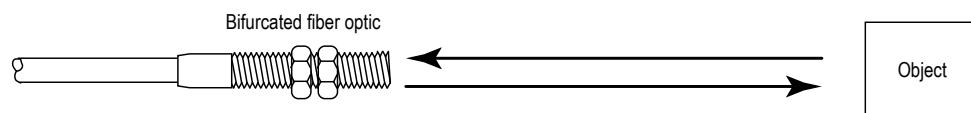

Bifurcated fiber optic assemblies are used for diffuse mode sensing. Two individual fibers may be positioned side-by-side and mechanically converged toward the sensing location, doubling the fiber area used to transmit and receive light and yielding more sensing range and/or excess gain than is specified on a diffuse mode sensor excess gain curve. Use diffuse mode sensing for object presence sensing or for color mark sensing.

Object Presence Sensing.

1. Mount the fiber optic sensing tip as close as possible to the object to be detected.
2. Increase the sensitivity of the scanner block to maximum by rotating the sensitivity control 15 or more turns clockwise.

- Place the object to be detected in the sensing position. The Alignment Indicating Device LED should be solid or pulsing faster than two beats per second.
- If the LED does not come on or if the AID pulse rate is very slow, reposition the fiber tip closer to the object.
- If repositioning is not possible, consider substituting a bifurcated fiber optic assembly with a larger bundle diameter or using two individual fiber optic assemblies, mechanically converged toward the object.
- Remove the object from the sensing location. If the alignment LED goes off, alignment is complete.
- Check the operation by alternately removing and replacing the object at the sensing location. The alignment LED should follow the action by coming on when the object is present and going off when the object is absent.
- If the alignment LED remains on when the object is removed, reduce the scanner block sensitivity (counter-clockwise rotation of the sensitivity control) until the LED goes off, plus two more full turns.
- Replace the object in the sensing position, and verify the alignment LED comes on or is pulsing faster than two beats per second.
- If this adjustment fails, consider methods of suppressing the reflections from background surfaces. Also, check the bifurcated fiber optic assembly for fiber breakage. Fiber breakage is evidenced by light returned to the scanner block (indicator LED on) when the fiber optic assembly is pointed away from all reflecting surfaces.

Color Marking Sensing. Scanner block models SBFV1 (red visible light) and SBFVG1 (green visible light) are used with a bifurcated fiber optic assembly to sense color differences. Their most common application is color mark sensing on printed webs. The random mix of transmit and receive fibers in a bifurcated fiber optic assembly is ideal for sensing color differences. Additionally, the bundle can be sized and/or shaped to exactly match a particular color registration mark.

- Position the darker of the two colors directly under the sensing tip of the bifurcated fiber optic assembly so that the visible image is completely contained within the boundaries of the dark area.
- Increase the sensitivity of the scanner block (clockwise rotation of the sensitivity control) until the alignment indicator LED just goes on.
- Decrease the sensitivity until the alignment LED goes off, plus two full turns.
- Present the lighter of the two colors to the visible image.
- Verify that the indicator LED comes on or is pulsing faster than two beats per second.
- Check the operation by alternating the dark and light colors under the sensing tip. The alignment LED should follow the action by coming on with the light colors and going off with the dark color.

Shiny materials should be sensed at a skew angle to avoid direct reflections that might reduce optical contrast between colors. Clear materials, like poly webs, may require opposed sensing of printed marks. Scanner block model SBFVG1 is required for sensing red on white and similar color differences.

Aligning Retroreflective Mode Sensors

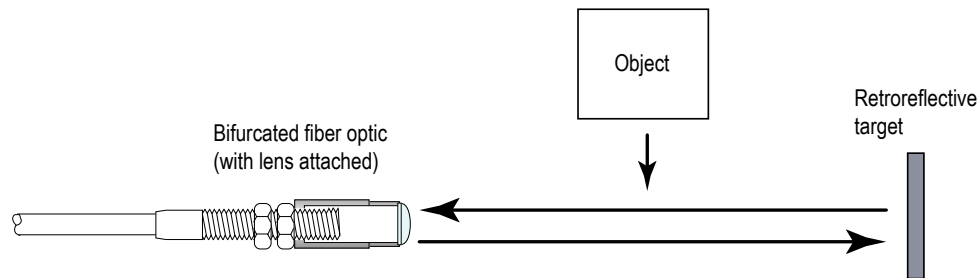

Sensor block models SBF1, SBF1MHS, or SBFV1 are used with a BT13S fiber and an L9 or L16F lens assembly for retroreflective sensing. Unlike most two-lens retroreflective sensing designs, a bifurcated fiber optic/lens combination has no minimum sensing distance. As a result, this combination is an excellent choice for retroreflective sensing across small parts conveyors or for high-speed retroreflective code reading applications.

Follow [Attaching the Lens Assembly](#) on page 4 to install a lens to the BT13S fiber optic assembly. Mount the fiber sensing assembly securely in place. Present the retroreflective target to the sensor and find the center of the sensing area by moving the target.

Part Present Applications

- Install the retroreflective material in the center of the sensing beam.
- Increase the sensitivity of the scanner block to maximum by rotating the sensitivity control 15 or more times clockwise.
- Place the object in the sensing position. If the LED goes off, alignment is complete.
- Check the operation by alternately removing and replacing the object from the sensing location. The alignment LED should follow the action by coming on when the object is absent and going off when the object is present.

If the alignment LED remains on when the object is present at the sensing position, the sensor is reacting to light being reflected directly from the object or from the backside of the lens (proxing is taking place). Reduce the sensitivity (counterclockwise rotation of the sensitivity control) until the alignment LED goes off, plus two more full turns. Remove the object from the sensing position and verify the alignment LED comes on or is pulsing at a rate faster than two beats per second. If this adjustment fails, consider the following solutions.

Skew Angle. If the object presents a flat, shiny surface, mount the fiber sensing end tip and the retroreflective target so that the light beam strikes the object's surface at an angle. Angles of about 10 degrees (or more) are often sufficient. This eliminates undesirable direction reflections from the object.

Lens Focus. Check the focusing of the lens on the fiber tip as outlined in [Attaching the Lens Assembly](#) on page 4. An unfocused lens can cause false light return to the receive fibers *directly from the backside of the lens*.

Broken Fibers. When the individual fiber strands within a bifurcated bundle break, light is spilled and some may be falsely returned to the receiver. This cross-coupling of light energy within a fiber optic assembly is evidenced by the alignment indicator LED remaining on when the fiber optic assembly is pointed away from all reflecting surfaces. Remove the lens assembly from the sensing tip for this test.

Code Reading Applications

1. Position the code plate so that the retroreflective code mark is in the center of the sensing beam.
2. Increase the sensitivity of the scanner block to maximum by rotating the sensitivity control 15 times or more clockwise.
3. Move the code plate so the retroreflective code mark is outside the sensing beam. If the alignment LED goes off, alignment is complete.
4. Check the operation by moving the code plate back and forth. The alignment LED should follow the action by coming on when the code mark is present and going off when the code mark is absent.

If the alignment LED remains on when the retroreflective code mark is moved out of the sensing beam, reduce the scanner block sensitivity (turn the sensitivity control CCW) until the LED goes off, plus two more full turns. Move the code mark back into the sensing beam to verify the alignment LED comes on or is pulsing faster than two beats per second. If the surface of the code plate is shiny, position the fiber optic sensing tip assembly to view the code plate and code marks at a skew angle.

Final Adjustment and Test

When alignment is completed and mounting hardware secured, finish wiring the scanner block by connecting the load to the output circuit of the power block (terminals 3 and/or 4). Refer to the hookup diagram for the power block in use. Check the operation of the load by placing an object in front of the sensing component (lens or sensing tip) and removing it. The load and the alignment indicator LED should follow the action. Adjust the logic module timing (if any), as required.

Logic modules (except models LM1, LM2, and LM10) include a light/dark programming jumper. Removing the jumper will invert the output state of the power block from normally open to normally closed, or vice versa. Caution: do not attempt to remove the programming jumper while power is applied to the MULTI-BEAM.

If you have any difficulties with the installation of your sensing system, contact your local Banner Engineering Corp representative or contact our applications engineers during normal business hours.

Specifications

Supply Voltage

Input power and output connections are made via 3- or 4-wire power blocks.
See datasheet 03499 (DC power blocks) or 03501 (AC power blocks) for more information.

Construction

Reinforced VALOX® housing; components totally encapsulated
Stainless steel hardware
Meets NEMA standards 1, 3, 12, and 13

Operating Temperature

-40 to 70 °C (-40 to 158 °F)

Response Time (independent of signal strength)

1 millisecond on and off
High-gain models (X model suffix) 10 milliseconds on and off
High-speed models (MHS model suffix) 0.3 milliseconds on and off

Sensitivity Adjustment

Easily-accessible, located on top of scanner block beneath o-ring gasketed nylon screw cover; 15-turn clutched control, rotate clockwise to increase sensitivity

Alignment Indicator

Red LED on top of scanner block
Banner's exclusive, patented Alignment Indicating Device (AID™) circuit lights the LED when the sensor detects its own modulated light source and pulses the LED at a rate proportional to the received light level.

Performance Curves

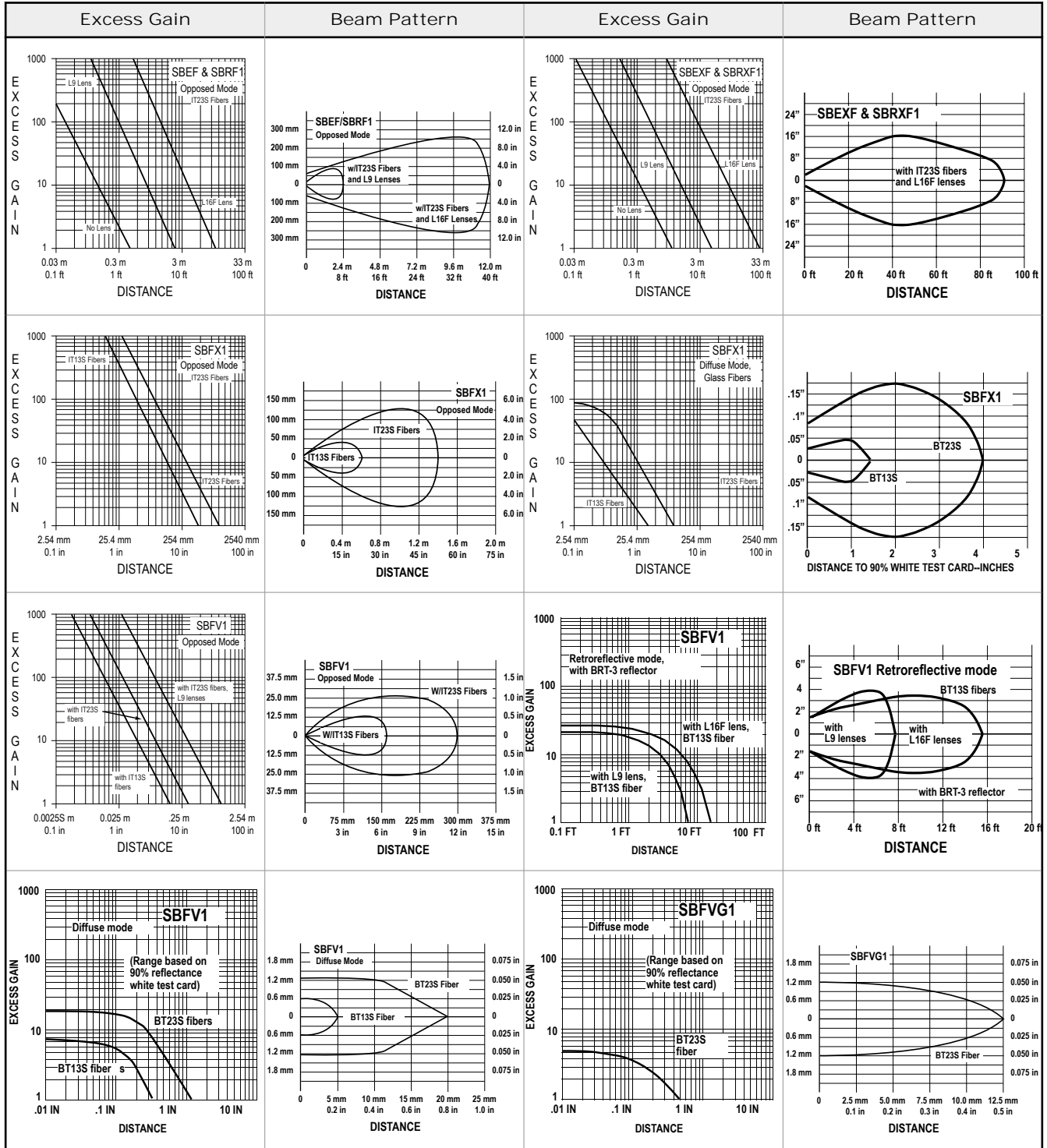

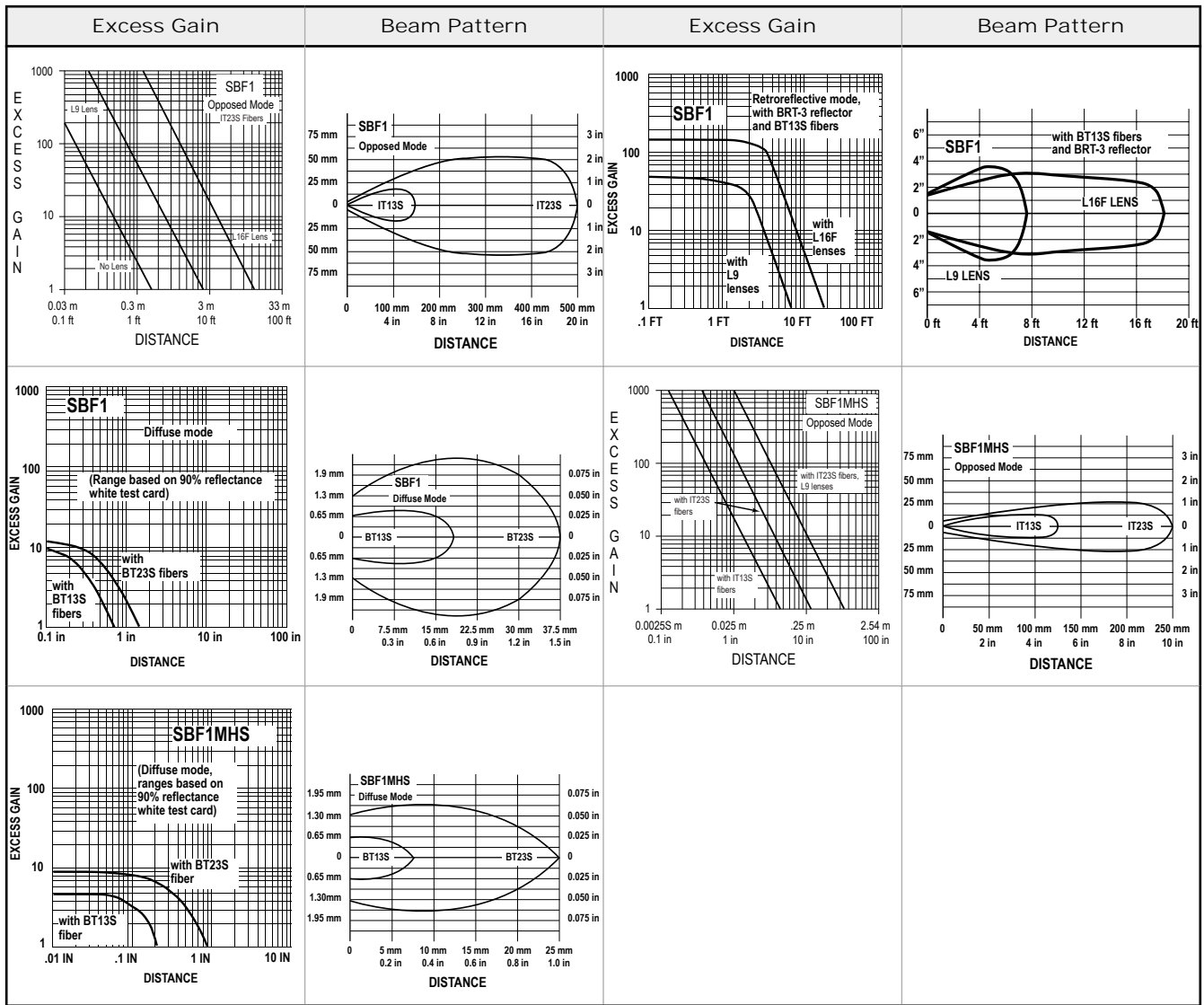

Dimensions

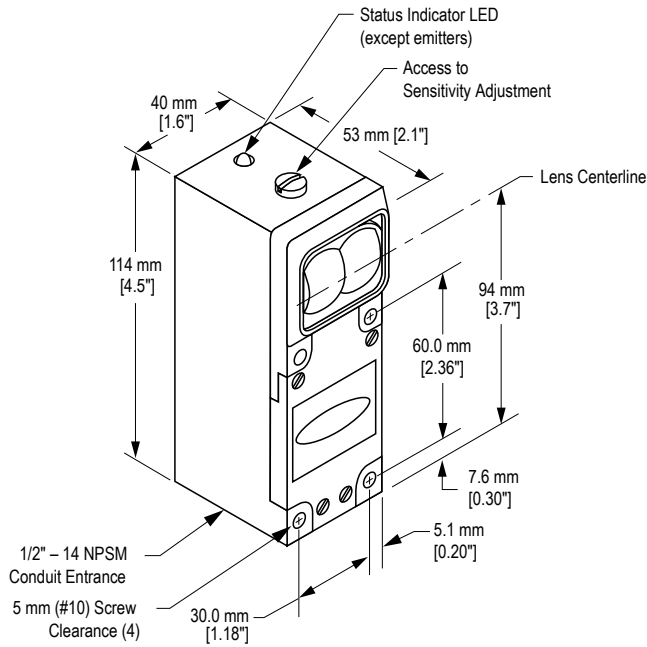

All measurements are listed in millimeters [inches], unless noted otherwise.

Accessories

The following fiber optic cables and lenses are commonly used with the sensors listed in this datasheet. Many other models are available.

Fiber Optic Assemblies

| IT13S | Features | Sensors | Range |
|-------|---------------------------------------------------------------------------------------------------------------------------------------------------------------------------------------------------------------------------------------------------------------------------------------------------|---------------------------------------|----------------------------------------------------------------------------------------------------------------------|
| | <ul style="list-style-type: none"> Fiber diameter: 1.6 mm (0.062 inches) Individual fiber Thread Stainless steel flexible conduit Used in pairs, but sold individually; two are required | D12E | 442 mm (17.4 inches) |
| IT23S | Features | Sensors | Range |
| | <ul style="list-style-type: none"> Fiber diameter: 3.18 mm (0.519 inches) Individual fiber 19 mm bend radius Thread Stainless steel flexible conduit Lenses available Used in pairs, but sold individually; two are required | D12E D12 QS18 R55F SME312 | 930 mm (36.6 inches) 550 mm (21.7 inches) 900 mm (35.4 inches) 1050 mm (41.3 inches) 250 mm (9.8 inches) |

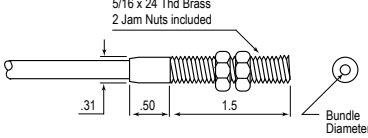
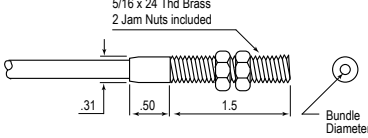
| BT13S | Features | Sensors | Range |
|-----------------------------------------------------------------------------------|---------------------------------------------------------------------------------------------------------------------------------------------------------------------------------------------------------|---------|---------------------|
|  | <ul style="list-style-type: none"> Fiber diameter: 1.6 mm (0.062 inches) Bifurcated fiber Thread Stainless steel flexible conduit | D12E | 68 mm (2.7 inches) |
| | | | |
| BT23S | Features | Sensors | Range |
|  | <ul style="list-style-type: none"> Fiber diameter: 3.18 mm (0.519 inches) Bifurcated fiber 19 mm bend radius Thread Stainless steel flexible conduit | D12E | 178 mm (7.0 inches) |
| | | D12 | 150 mm (5.9 inches) |
| | | QS18 | 100 mm (3.9 inches) |
| | | R55F | 110 mm (4.3 inches) |
| | | SME312 | 25 mm (0.98 inches) |

Lenses

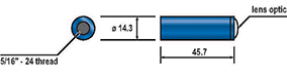
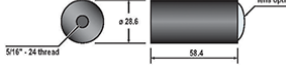
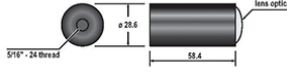
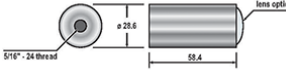
| | |
|-------------------------------------------------------------------------------------------------------------------------------------------------------------------------------------------------------------------------------------------------------------------------------------------------------------------------------------------|-------------------------------------------------------------------------------------------------------------------------------------------------------------------------------------------------------------------------------------------------------------------------------------------------------------------------------------|
| <p>L9</p> <ul style="list-style-type: none"> 3.18 mm core diameter 19 mm bend radius 12.5 mm lens, 12.5 mm focal length Aluminum housing Suitable for all but highly corrosive environments  | <p>L16F</p> <ul style="list-style-type: none"> 3.18 mm core diameter 19 mm bend radius 25 mm lens, 44 mm focal length Delrin housing Maximum operating temperature is 100 °C (212 °F)  |
| <p>L16FAL</p> <ul style="list-style-type: none"> 3.18 mm core diameter 19 mm bend radius 25 mm lens, 44 mm focal length Aluminum housing Suitable for all but highly corrosive environments  | <p>L16FSS</p> <ul style="list-style-type: none"> 3.18 mm core diameter 19 mm bend radius 25 mm lens, 44 mm focal length Stainless steel housing Suitable for all environments  |

Banner Engineering Corp. Limited Warranty

Banner Engineering Corp. warrants its products to be free from defects in material and workmanship for one year following the date of shipment. Banner Engineering Corp. will repair or replace, free of charge, any product of its manufacture which, at the time it is returned to the factory, is found to have been defective during the warranty period. This warranty does not cover damage or liability for misuse, abuse, or the improper application or installation of the Banner product.

THIS LIMITED WARRANTY IS EXCLUSIVE AND IN LIEU OF ALL OTHER WARRANTIES WHETHER EXPRESS OR IMPLIED (INCLUDING, WITHOUT LIMITATION, ANY WARRANTY OF MERCHANTABILITY OR FITNESS FOR A PARTICULAR PURPOSE), AND WHETHER ARISING UNDER COURSE OF PERFORMANCE, COURSE OF DEALING OR TRADE USAGE.

This Warranty is exclusive and limited to repair or, at the discretion of Banner Engineering Corp., replacement. IN NO EVENT SHALL BANNER ENGINEERING CORP. BE LIABLE TO BUYER OR ANY OTHER PERSON OR ENTITY FOR ANY EXTRA COSTS, EXPENSES, LOSSES, LOSS OF PROFITS, OR ANY INCIDENTAL, CONSEQUENTIAL OR SPECIAL DAMAGES RESULTING FROM ANY PRODUCT DEFECT OR FROM THE USE OR INABILITY TO USE THE PRODUCT, WHETHER ARISING IN CONTRACT OR WARRANTY, STATUTE, TORT, STRICT LIABILITY, NEGLIGENCE, OR OTHERWISE.

Banner Engineering Corp. reserves the right to change, modify or improve the design of the product without assuming any obligations or liabilities relating to any product previously manufactured by Banner Engineering Corp. Any misuse, abuse, or improper application or installation of this product or use of the product for personal protection applications when the product is identified as not intended for such purposes will void the product warranty. Any modifications to this product without prior express approval by Banner Engineering Corp will void the product warranties. All specifications published in this document are subject to change; Banner reserves the right to modify product specifications or update documentation at any time. Specifications and product information in English supersede that which is provided in any other language. For the most recent version of any documentation, refer to: www.bannerengineering.com.