

MAXI-AMP™ System

CP Series Power Supply Modules

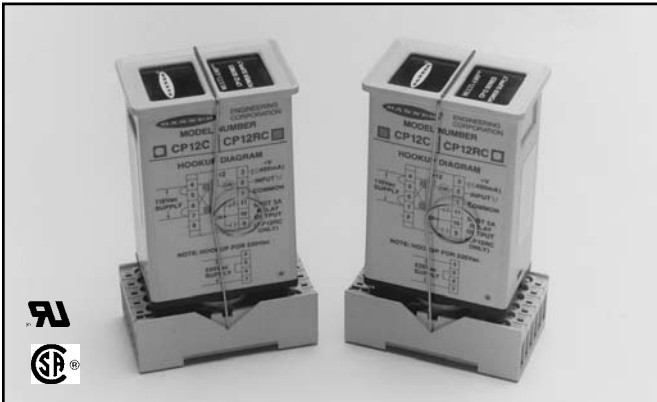

MODEL	INPUT VOLTAGE	OUTPUT POWER	OUTPUT DEVICE
CP12C	105 to 130V ac (15 VA)	400 milliamps maximum for 10-30V dc sensing devices	None
CP12RC	210 to 250V ac (15 VA) 50/60Hz		SPDT 5-amp electro-mechanical

MAXI-AMP CP Series power supply modules provide a convenient source of power for 10 to 30V dc sensing devices such as Banner self-contained dc sensors and/or any of the Banner logic modules and remote amplifiers. It is an excellent way to supply power to a system using multiple MAXI-AMP modules and associated sensors.

Model CP12RC includes a relay which may be switched by a current sinking device (pin #2) or a current sourcing device (pin #8). The relay is a single-pole double-throw (SPDT) 5 amp electromechanical type.

These supplies are designed for either 120 or 220/240V ac input voltage (see hookup diagrams). They offer 400 milliamps for powering 10 to 30V dc devices.

CP series power supplies are built into the rugged MAXI-AMP housing. They connect via a standard 11-pole round-pin relay socket (Banner RS-11). The RS-11 socket allows DIN rail mounting of the power supply. Operating temperature for CP series power supply modules is 0 to 50 degrees C (32 to 122 degrees F).

Load Curve

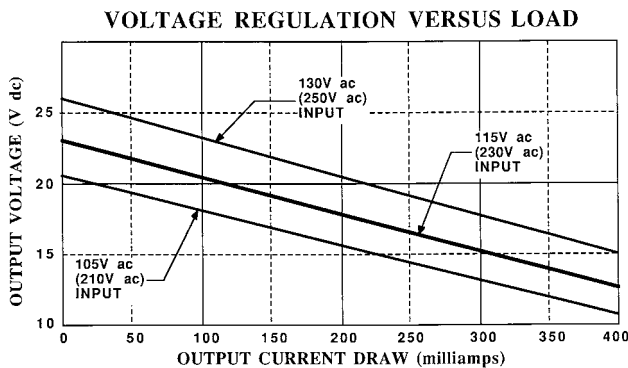

Dimensions

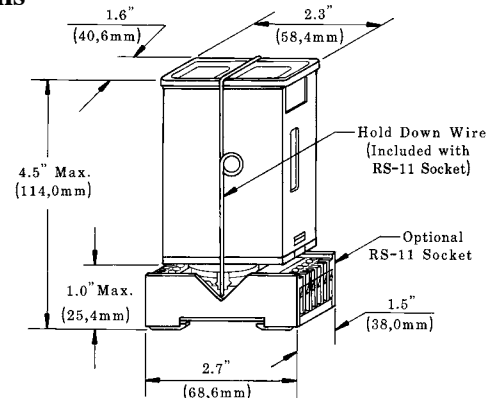

120V ac Hookup Diagram, CP12C

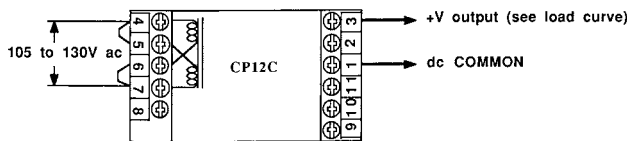

120V ac Hookup Diagram, CP12RC

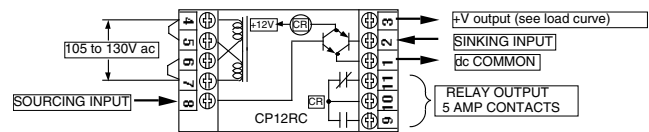

220/240V ac Hookup Diagram, CP12C

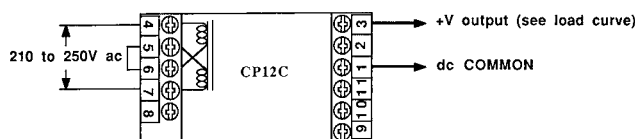

220/240V ac Hookup Diagram, CP12RC

