

8 7 6 5 4 3 2 1

12.0
[.47]

OUTPUT INDICATOR

381
[15.0]
INSTALLED LENGTH

82.5
[3.25]

108.0
[4.25]

108.0
[4.25]

8.0
[.32]

18.6
[.73]

SEE DETAIL A

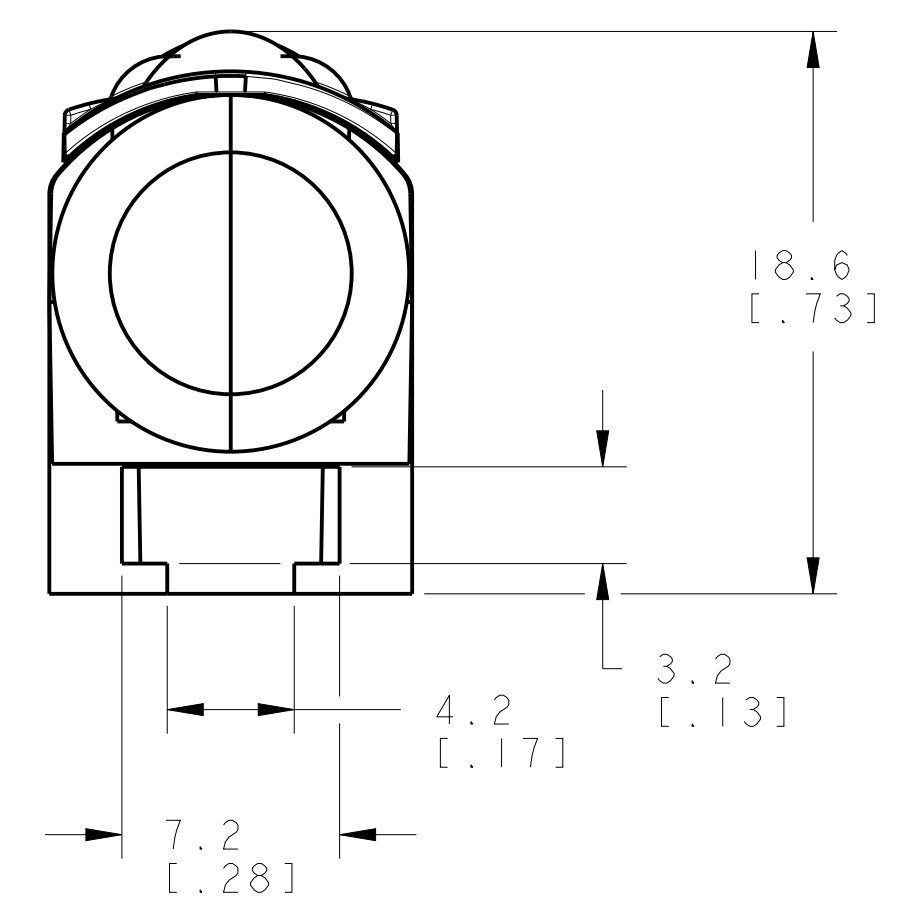

DETAIL A
SCALE 4:1

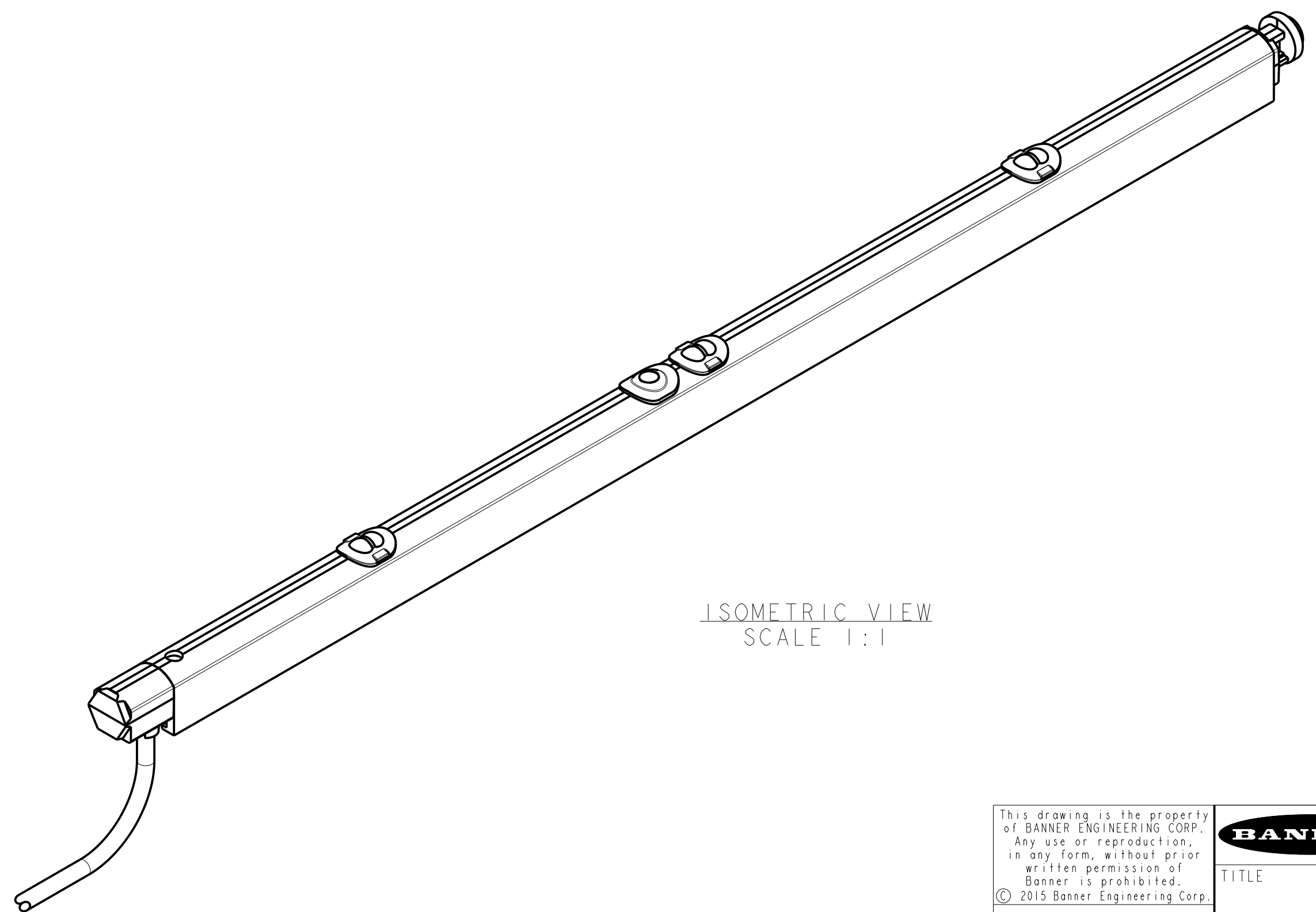

ISOMETRIC VIEW
SCALE 1:1

NOTES:
1. ALL DIMENSIONS ARE MILLIMETERS [INCHES] UNLESS OTHERWISE NOTED.
2. REFER TO "www.bannerengineering.com" FOR ADDITIONAL DATA AND SPECIFICATIONS.

<small>This drawing is the property of BANNER ENGINEERING CORP. Any use or reproduction in any form, without prior written permission of Banner is prohibited. © 2015 Banner Engineering Corp.</small>		BANNER BANNER ENGINEERING CORP. www.bannerengineering.com	
TITLE TTR381XXSC3D-XX		REV: A	
SIZE D	DRAWING NO. 225565	SHEET 1 OF 1	
SCALE 3:2		CREO	

8 7 6 5 4 3 2 1