

Features

AC- and DC-powered sensors with solid-state outputs

To view or download the latest technical information about this product, including specifications, dimensions, accessories, and wiring, go to www.bannerengineering.com.

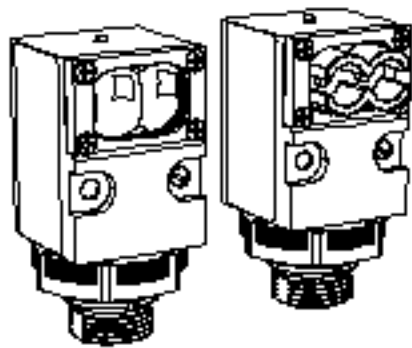

- Choose models for 10 to 30 V DC or 24 to 250 V AC operation
- DC models have bipolar solid-state outputs: one NPN (sinking) and one PNP (sourcing)
- AC models have an SPST solid-state output rated for up to 3/4 amp with simple 2-wire connection
- All models have a rear panel sensitivity adjustment and light/dark operate switch
- DC models include Banner's Alignment Indicating Device (AID™) system
- Choose models with integral 2 m (6.5 ft) cable or Mini-style QD (quick-disconnect) connector; 9 m (30 ft) cables are also available

WARNING:



- Do not use this device for personnel protection
- Using this device for personnel protection could result in serious injury or death.
- This device does not include the self-checking redundant circuitry necessary to allow its use in personnel safety applications. A device failure or malfunction can cause either an energized (on) or de-energized (off) output condition.

Models

To order the 9 m (30 ft) PVC cable model, add the suffix "W/30" to the cabled model number. For example, SMA91E W/30.

A model with a QD connector requires a mating cable; see ["Quick-Disconnect Cables" on page 10](#).

SMx91x Opposed Mode Emitter (E) and Receiver (R) Models

Infrared, 880 nm

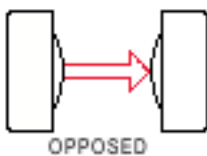

Models	Range	Connection	Supply Voltage	Output Type
SMA91E	60 m (200 ft)	2 m (6.5 ft) cable	10 to 250 V AC/DC	-
SMA91EQD		3-pin 7/8 in-16UNF Quick Disconnect		
SM91R		2 m (6.5 ft) cable	10 to 30 V DC	Bipolar NPN/PNP
SM91RQD		4-pin 7/8 in-16UNF Quick Disconnect		
SM2A91R		2 m (6.5 ft) cable	24 to 250 V AC	SPST SCR Solid-state 2-wire
SM2A91RQD		3-pin 7/8 in-16UNF Quick Disconnect		
SMA91ESR	3 m (10 ft)	2 m (6.5 ft) cable	10 to 250 V AC/DC	-
SMA91ESRQD		3-pin 7/8 in-16UNF Quick Disconnect		
SM91RSR		2 m (6.5 ft) cable	10 to 30 V DC	Bipolar NPN/PNP
SM91RSRQD		4-pin 7/8 in-16UNF Quick Disconnect		
SM2A91RSR		2 m (6.5 ft) cable	24 to 250 V AC	SPST SCR Solid-state 2-wire
SM2A91RSRQD		3-pin 7/8 in-16UNF Quick Disconnect		



SMx912 Retroreflective Mode Models

Visible red, 650 nm

Retroreflective range is specified using one model BRT-3 retroreflector (3-inch diameter). Actual sensing range may be more or less than specified, depending upon the efficiency and reflective area of the retroreflector used.

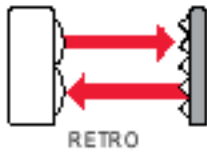

Non-polarized retroreflective models

Models	Range	Connection	Supply Voltage	Output Type
SM912LV	0.15 to 9 m (6 in to 30 ft)	2 m (6.5 ft) cable	10 to 30 V DC	Bipolar NPN/PNP
SM912LVQD		4-pin 7/8 in-16UNF Quick Disconnect		
SM2A912LV	0.15 to 9 m (6 in to 30 ft)	2 m (6.5 ft) cable	24 to 250 V AC	SPST SCR Solid-state 2-Wire
SM2A912LVQD		3-pin 7/8 in-16UNF Quick Disconnect		



Polarized retroreflective models

Models ⁽¹⁾	Range	Connection	Supply Voltage	Output Type
SM912LVAG	0.3 to 4.5 m (1 ft to 15 ft)	2 m (6.5 ft) cable	10 to 30 V DC	Bipolar NPN/PNP
SM912LVAGQD		4-pin 7/8 in-16UNF Quick Disconnect		
SM2A912LVAG	0.3 to 4.5 m (1 ft to 15 ft)	2 m (6.5 ft) cable	24 to 250 V AC	SPST SCR Solid-state 2-Wire
SM2A912LVAGQD		3-pin 7/8 in-16UNF Quick Disconnect		

SMx912 Diffuse Mode Models

Infrared, 880 nm

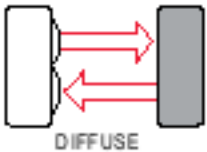

Models	Range	Connection	Supply Voltage	Output Type
SM912D	760 mm (30 in)	2 m (6.5 ft) cable	10 to 30 V DC	Bipolar NPN/PNP
SM912DQD		4-pin 7/8 in-16UNF Quick Disconnect		
SM2A912D	760 mm (30 in)	2 m (6.5 ft) cable	24 to 250 V AC	SPST SCR Solid-state 2-Wire
SM2A912DQD		3-pin 7/8 in-16UNF Quick Disconnect		
SM912DSR	380 mm (15 in)	2 m (6.5 ft) cable	10 to 30 V DC	Bipolar NPN/PNP
SM912DSRQD		4-pin 7/8 in-16UNF Quick Disconnect		
SM2A912DSR	380 mm (15 in)	2 m (6.5 ft) cable	24 to 250 V AC	SPST SCR Solid-state 2-Wire
SM2A912DSRQD		3-pin 7/8 in-16UNF Quick Disconnect		

SMx912x Convergent Mode Models

Visible red or infrared

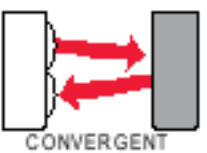

⁽¹⁾ Use polarized models when shiny objects will be sensed.

Visible red models

Models (Visible Red, 650 nm)	Range	Cable*	Supply Voltage	Output Type
SM912CV	38 mm (1.5 in) Spot Size at Focus: 1.5 mm (0.06 in)	2 m (6.5 ft) cable	10 to 30 V DC	Bipolar NPN/PNP
SM912CVQD		4-pin 7/8 in-16UNF Quick Disconnect		
SM2A912CV		2 m (6.5 ft) cable	24 to 250 V AC	SPST SCR Solid-state 2-Wire
SM2A912CVQD		3-pin 7/8 in-16UNF Quick Disconnect		

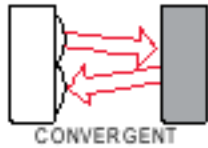

Infrared models

Models (Infrared, 880 nm)	Range	Cable*	Supply Voltage	Output Type
SM912C	38 mm (1.5 in)	2 m (6.5 ft) cable	10 to 30 V DC	Bipolar NPN/PNP
SM912CQD		4-pin 7/8 in-16UNF Quick Disconnect		
SM2A912C		2 m (6.5 ft) cable	24 to 250 V AC	SPST SCR Solid-state 2-Wire
SM2A912CQD		3-pin 7/8 in-16UNF Quick Disconnect		

SMx91x Glass Fiber Optic Individual Emitter or Receiver Models

Infrared, 880 nm . Use where the separation between emitting and receiving fibers is more than a few feet, or where it is inconvenient to run both fibers from a single sensor. Watertight o-ring-sealed sensor/fiber interface.

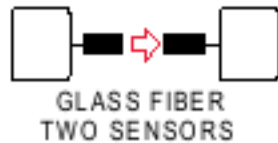

Models	Range	Connection	Supply Voltage	Output Type
SMA91EF	Range varies with the fiber used	2 m (6.5 ft) cable	10 to 250 V AC/DC	-
SMA91EFQD		3-pin 7/8 in-16UNF Quick Disconnect		
SM91RF		2 m (6.5 ft) cable	10 to 30 V DC	Bipolar NPN/PNP
SM91RFQD		4-pin 7/8 in-16UNF Quick Disconnect		
SM2A91RF		2 m (6.5 ft) cable	24 to 250 V AC	SPST SCR Solid-state 2-Wire
SM2A91RFQD		3-pin 7/8 in-16UNF Quick Disconnect		

SMx912x Glass Fiber Optic Models

Infrared, 880 nm . Watertight o-ring-sealed sensor/fiber interface.

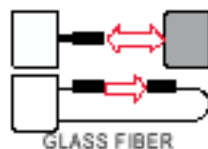

Models	Range	Connection	Supply Voltage	Output Type
SM912F	Range varies with sensing mode and fiber optics used	2 m (6.5 ft) cable	10 to 30 V DC	Bipolar NPN/PNP
SM912FQD		4-pin 7/8 in-16UNF Quick Disconnect		
SM2A912F		2 m (6.5 ft) cable	24 to 250 V AC	SPST SCR Solid-state 2-Wire
SM2A912FQD		3-pin 7/8 in-16UNF Quick Disconnect		

Wiring Diagrams

DC Wiring Diagrams

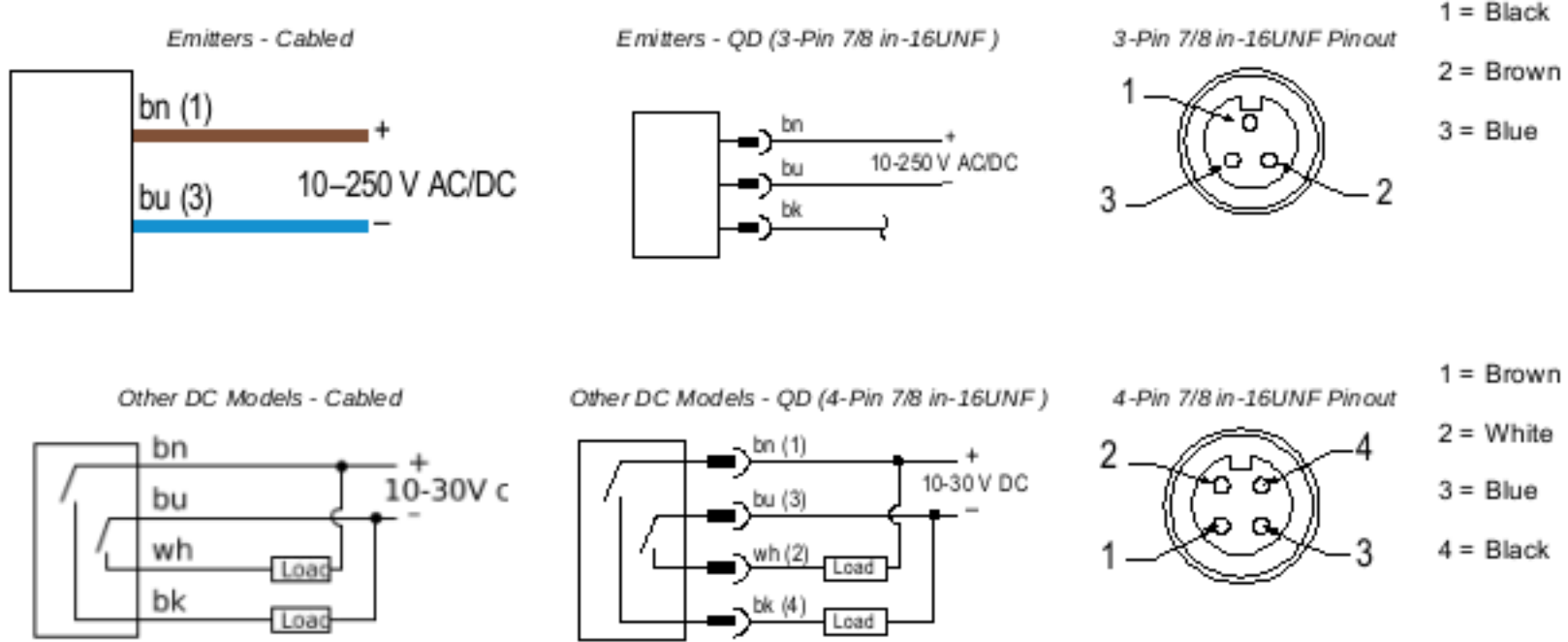

AC Wiring Diagrams

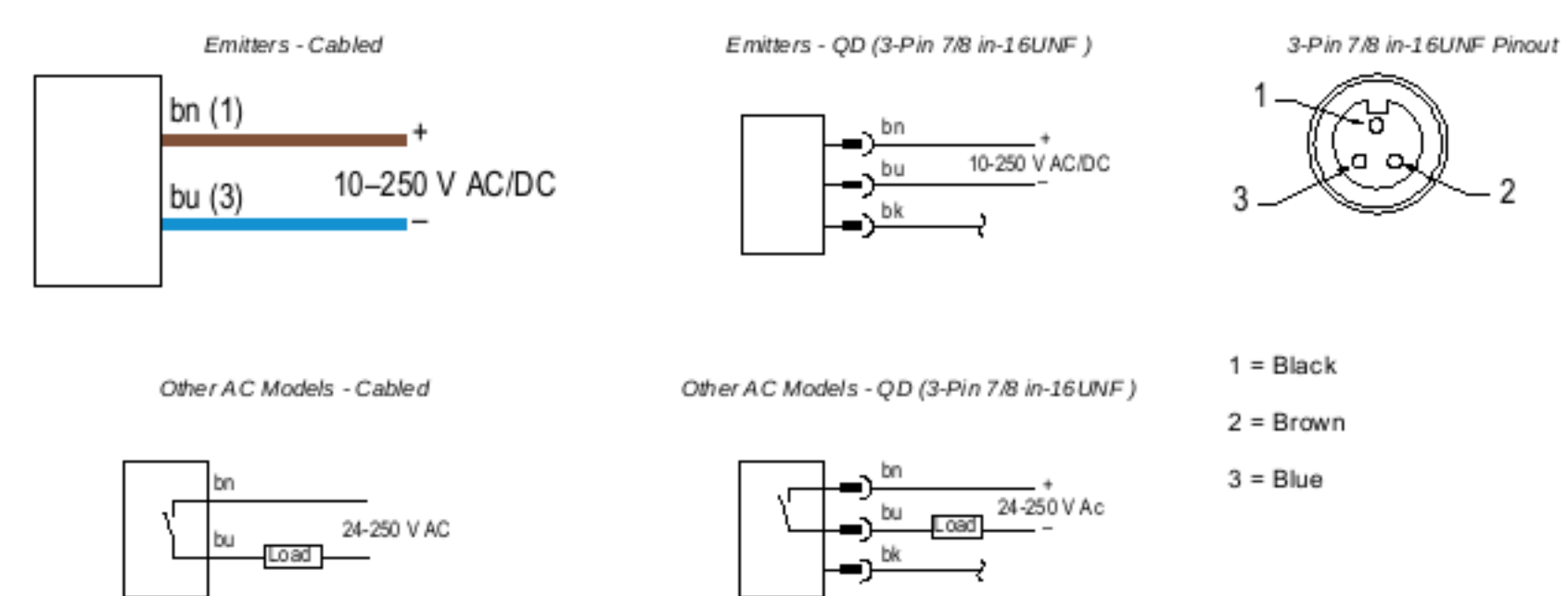

Specifications

FCC Part 15 Class A for Unintentional Radiators

This equipment has been tested and found to comply with the limits for a Class A digital device, pursuant to Part 15 of the FCC Rules. These limits are designed to provide reasonable protection against harmful interference when the equipment is operated in a commercial environment. This equipment generates, uses, and can radiate radio frequency energy and, if not installed and used in accordance with the instruction manual, may cause harmful interference to radio communications. Operation of this equipment in a residential area is likely to cause harmful interference in which case the user will be required to correct the interference at his own expense.

(Part 15.21) Any changes or modifications not expressly approved by the party responsible for compliance could void the user's authority to operate this equipment.

Industry Canada ICES-003(A)

This device complies with CAN ICES-3 (A)/NMB-3(A). Operation is subject to the following two conditions: 1) This device may not cause harmful interference; and 2) This device must accept any interference received, including interference that may cause undesired operation.

Cet appareil est conforme à la norme NMB-3(A). Le fonctionnement est soumis aux deux conditions suivantes : (1) ce dispositif ne peut pas occasionner d'interférences, et (2) il doit tolérer toute interférence, y compris celles susceptibles de provoquer un fonctionnement non souhaité du dispositif.

DC Models Specifications

Supply Voltage and Current

10 to 30 V dc at 20 mA maximum, exclusive of load;
except for SMA91E, ESR and EF emitters, which operate
from 10 to 250 V ac or dc, 10 mA max.

Supply Protection Circuitry

Protected against reverse polarity and transient voltages

Output Configuration

Bipolar: One current sourcing (PNP) and one current sinking
(NPN) open-collector transistor

Construction

Reinforced thermoplastic polyester housing, totally
encapsulated, molded acrylic lenses and stainless steel
hardware

Output Response Time

Receivers only: 8 milliseconds ON and 4 milliseconds OFF,
independent of signal strength.

All other models: 4 milliseconds ON/OFF

NOTE: 100 millisecond delay on power-up; outputs do not conduct during this delay.

Repeatability

Opposed and Glass Fiber Optic Emitter-Receiver pairs: 1.0
millisecond

Retro, Diffuse, Convergent and Glass Fiber Optic Models: 1.3
milliseconds

Adjustments

Light/Dark Operate select switch and Sensitivity control
potentiometer, both located at rear of sensor

Output Rating

250 mA continuous, each output

Off-state leakage current: less than 10 microamps

Output saturation voltage: (PNP output) less than 1 volt at 10
mA and less than 2 volts at 250 mA

Output saturation voltage: (NPN output) less than 200
millivolts at 10 mA and less than 1 volt at 250 mA

Indicators

Alignment Indicating Device (AID™) lights a top-mounted red
LED indicator whenever the sensor sees a "light" condition; its
pulse rate is proportional to the light signal strength (the
stronger the signal, the faster the pulse rate).

Model SMA91E and SM91ESR emitters: visible-red "tracer
beam" indicates "Power ON" and enables line-of-sight
alignment.

Environmental Rating

IP66

AC Models Specifications

Supply Voltage and Current

24 to 250 V ac (50/60 Hz);
except for SMA91E, ESR and EF emitters, which operate
from 10 to 250 V ac or dc

Supply Protection Circuitry

Protected against transient voltages

Output Configuration

SPST SCR solid-state relay with either normally closed or
normally open contact (light/dark operate selectable); 2-wire
hookup

Connections

PVC-jacketed 2 m (6.5 ft) or 9 m (30 ft) cables or 4-pin Mini-
style quick-disconnect (QD) fitting available.

NOTE: Opposed-mode emitters use 3-
pin Mini-style QD fitting. See "Quick-
Disconnect Cables" on page 10.

Operating Conditions

Temperature: -20 °C to +70 °C (-4 °F to +158 °F)

90% at +50 °C maximum relative humidity (non-condensing)

Certifications



Banner Engineering BV
Park Lane, Culliganlaan 2F bus 3
1831 Diegem, BELGIUM



Turck Banner LTD Blenheim House
Blenheim Court
Wickford, Essex SS11 8YT
GREAT BRITAIN



Required Overcurrent Protection



WARNING: Electrical connections must
be made by qualified personnel in
accordance with local and national
electrical codes and regulations.

Overcurrent protection is required to be provided by end
product application per the supplied table.

Overcurrent protection may be provided with external fusing
or via Current Limiting, Class 2 Power Supply.

Supply wiring leads < 24 AWG shall not be spliced.

For additional product support, go
to www.bannerengineering.com.

Supply Wiring (AWG)	Required Overcurrent Protection (A)	Supply Wiring (AWG)	Required Overcurrent Protection (A)
20	5.0	28	1.0
22	3.0	28	0.8
24	1.0	30	0.5

Construction

Reinforced thermoplastic polyester housing, totally
encapsulated, molded acrylic lenses and stainless steel
hardware

Output Rating

Minimum load current 10 mA, max. steady-state load
capability 750 mA to 50 °C ambient (122 °F), 500 mA to 70 °C
ambient (158 °F)

Inrush capability: 4 amps for 1 second (non-repetitive)

Off-state leakage: current less than 1.7 mA rms

On-state voltage drop: ≤ 5 volts rms at 750 mA load, ≤ 10
volts rms at 15 mA load

Output Response Time

Receivers only: 8 milliseconds ON and 4 milliseconds OFF, independent of signal strength.
 All other models: 4 milliseconds ON/OFF
 OFF time does not include load response of up to 1/2 ac cycle (8.3 milliseconds).
 Response time specification of the load should be considered when total response time is important.

NOTE: 300 millisecond delay on power-up; outputs do not conduct during this delay.

Repeatability

Opposed and Glass Fiber Optic Emitter-Receiver pairs: 1.0 millisecond
 Retro, Diffuse, Convergent and Glass Fiber Optic Models: 2.6 milliseconds

Adjustments

Light/Dark Operate select switch and Sensitivity control potentiometer, both located at rear of sensor

Indicators

Top-mounted red LED indicator lights when output is conducting.
 Model SMA91E and SM91ESR emitters: visible-red "tracer beam" indicates "Power ON" and enables line-of-sight alignment.

Output Protection Circuitry

Protected against false pulse on power-up

Application Notes

1. 912 Series ac sensors can be destroyed from overload conditions.
2. Use on low voltage requires careful analysis of the load to determine if the leakage current or on-state voltage of the sensor will interfere with proper operation of the load.
3. The false-pulse protection feature may cause momentary drop-out of the load when the sensor is wired in series or parallel with mechanical switch contacts.

Environmental Rating

IP66

Connections

PVC-jacketed 2 m (6.5 ft) or 9 m (30 ft) cables or 3-pin Mini-style (QD) fitting available. See "Quick-Disconnect Cables" on page 10.

Operating Conditions

Temperature: -20 °C to +70 °C (-4 °F to +158 °F)
 90% at +50 °C maximum relative humidity (non-condensing)

Certifications

 Banner Engineering BV
 Park Lane, Culliganlaan 2F bus 3
 1831 Diegem, BELGIUM

 Turck Banner LTD Blenheim House
 Blenheim Court
 Wickford, Essex SS11 8YT
 GREAT BRITAIN



Required Overcurrent Protection



WARNING: Electrical connections must be made by qualified personnel in accordance with local and national electrical codes and regulations.

Overcurrent protection is required to be provided by end product application per the supplied table.

Overcurrent protection may be provided with external fusing or via Current Limiting, Class 2 Power Supply.

Supply wiring leads < 24 AWG shall not be spliced.

For additional product support, go to www.bannerengineering.com.

Supply Wiring (AWG)	Required Overcurrent Protection (A)	Supply Wiring (AWG)	Required Overcurrent Protection (A)
20	5.0	26	1.0
22	3.0	28	0.8
24	1.0	30	0.5

Dimensions

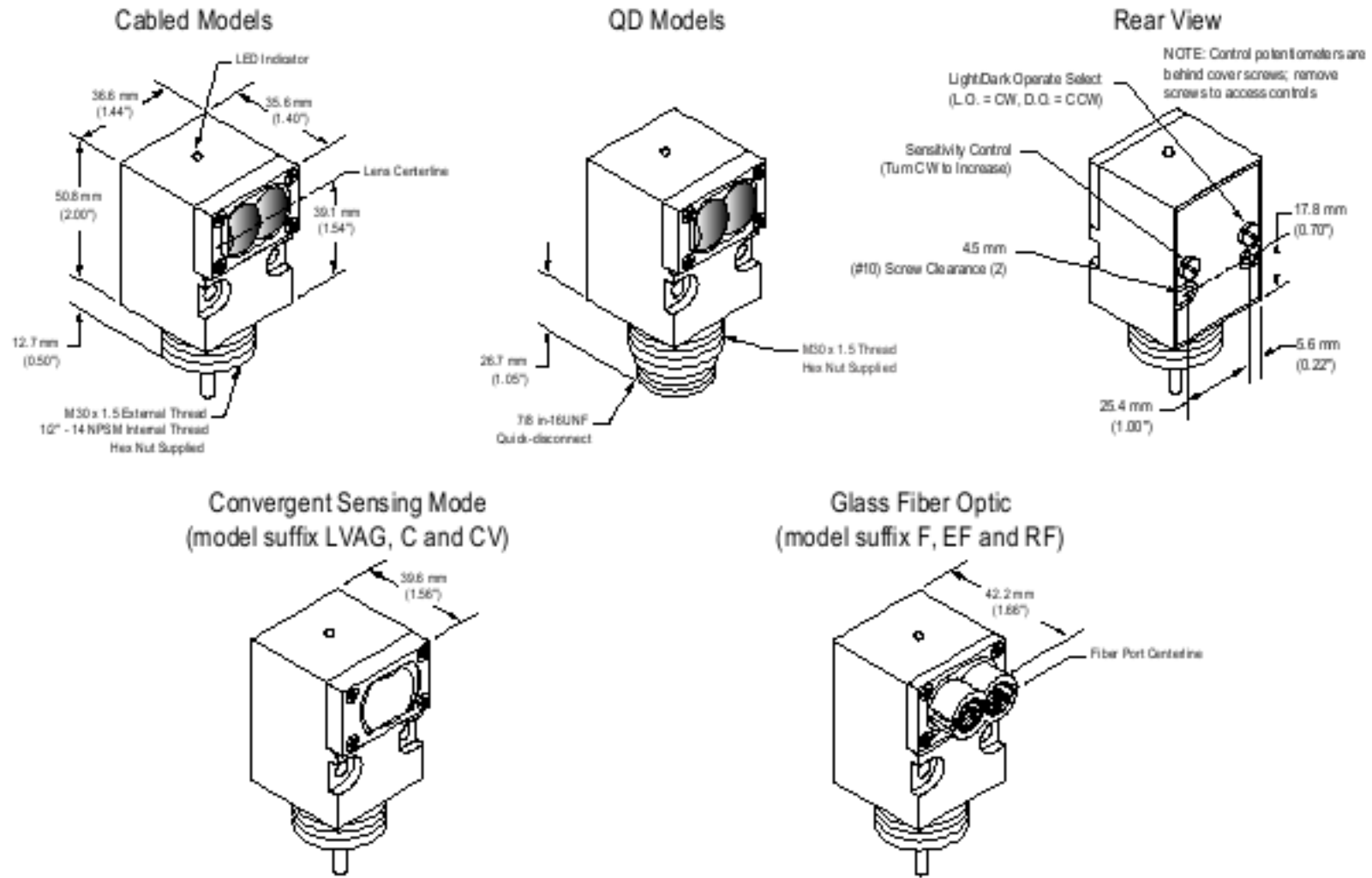

Excess Gain

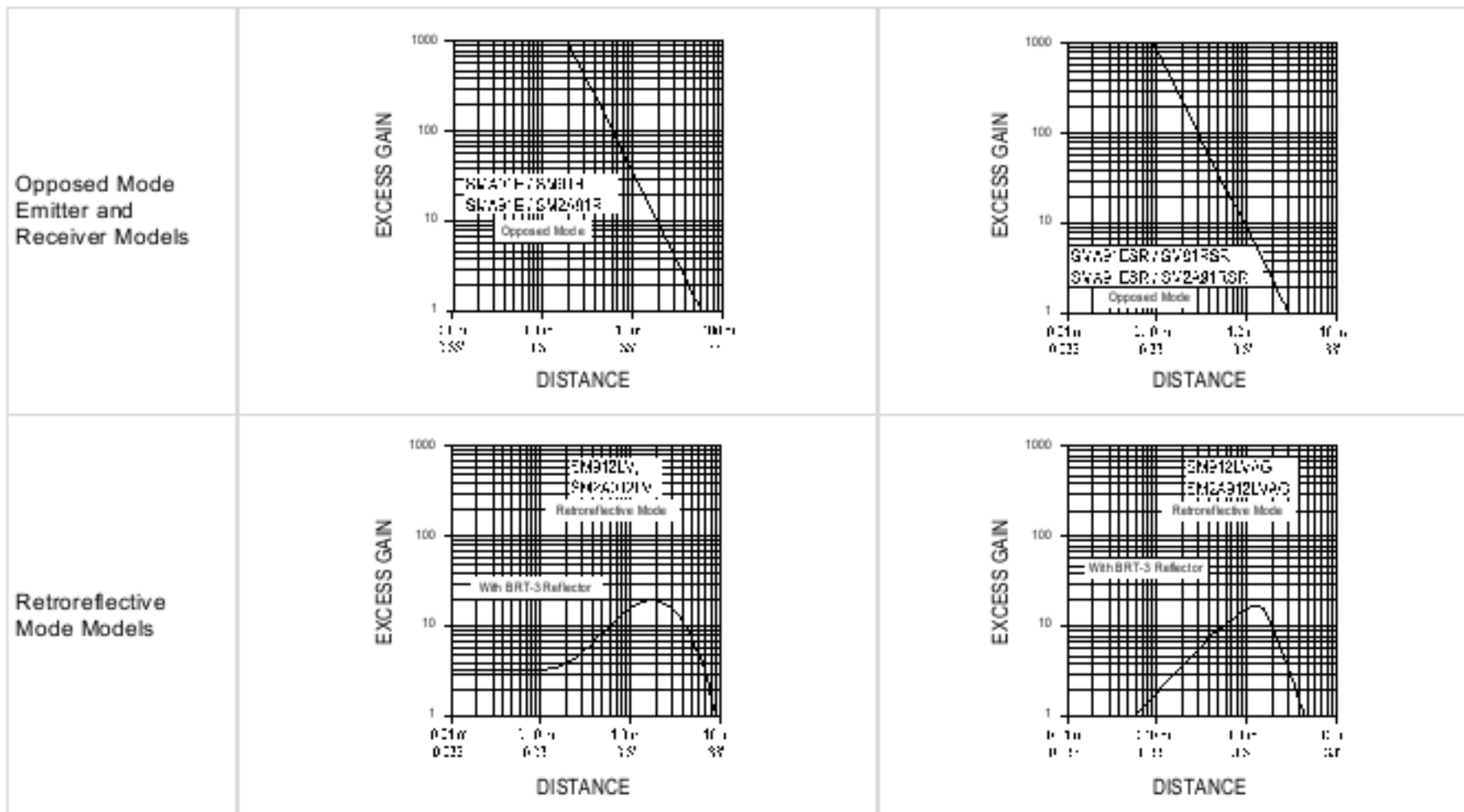

Continued on page 8

Continued from page 7

<p>Diffuse Mode Models</p>		
<p>Convergent Mode Models</p>	<p>Visible Red 650 nm</p>	<p>Infrared 880 nm</p>
<p>Glass Fiber Optic Individual Emitter or Receiver Models</p>		
<p>Glass Fiber Optic Models</p>		

Beam Patterns

<p>Opposed Mode Emitter and Receiver Models</p>	<p>91E / 91R Opposed Mode</p> <p>DISTANCE</p>	<p>91ESR / 91RSR Opposed Mode</p> <p>DISTANCE</p>
<p>Retroreflective Mode Models</p>	<p>Non-Polarized</p> <p>912LV Retroreflective Mode</p> <p>With BRT-3 Reflector</p> <p>DISTANCE</p>	<p>Polarized</p> <p>912LVAG Retroreflective Mode</p> <p>With BRT-3 Reflector</p> <p>DISTANCE</p>
<p>Diffuse Mode Models</p>	<p>912D Diffuse Mode</p> <p>DISTANCE</p>	<p>912DSR Diffuse Mode</p> <p>DISTANCE</p>
<p>Convergent Mode Models</p>	<p>Visible Red 650 nm</p> <p>912CV Convergent Mode</p> <p>DISTANCE</p>	<p>Infrared 880 nm</p> <p>SM912C, SM2A912C Convergent Mode</p> <p>DISTANCE</p>

Continued on page 9

Continued from page 9

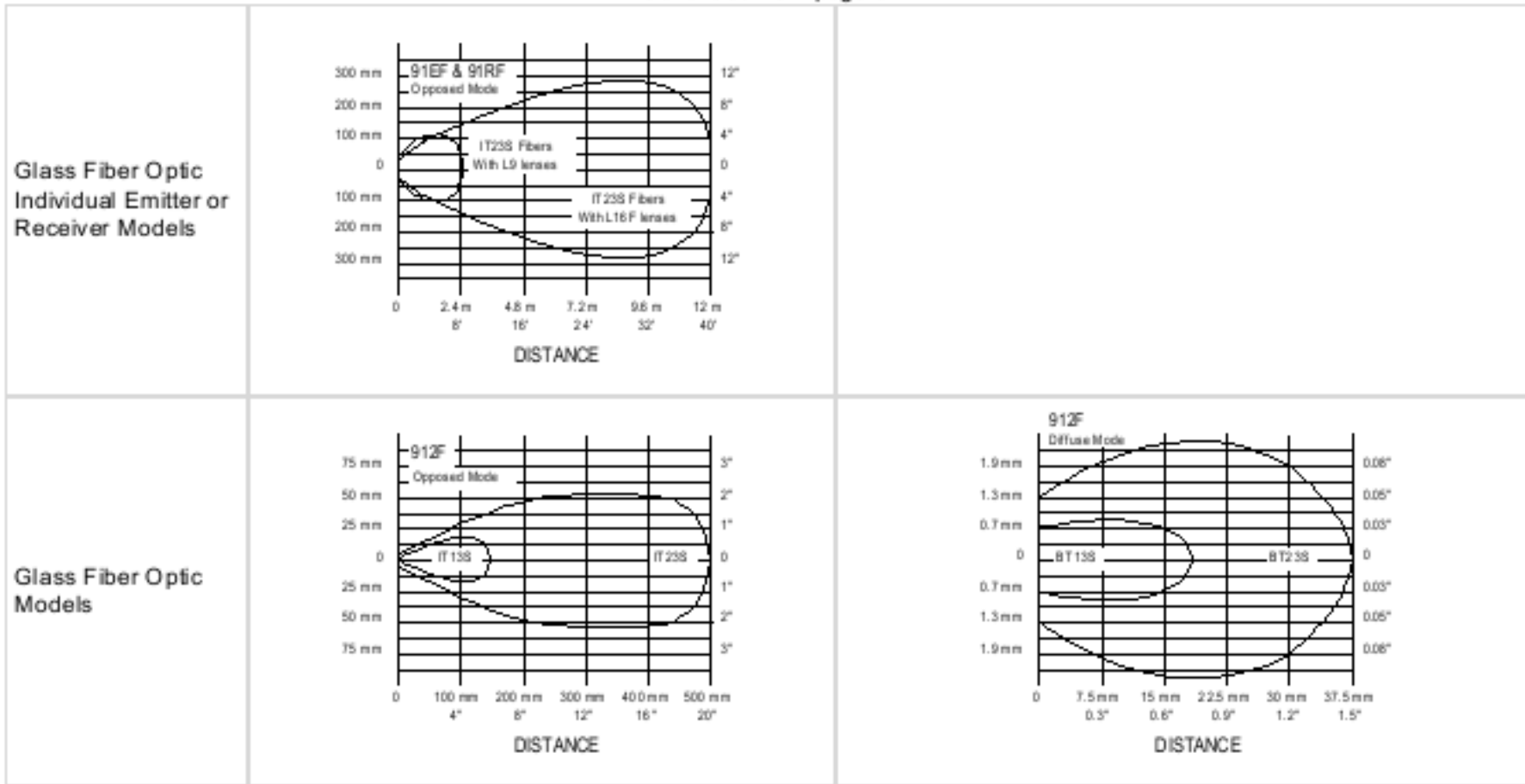

Accessories

Quick-Disconnect Cables

3-pin Single-Ended 7/8-in Female Cordsets				
Model	Length	Style	Dimensions	Pinout (Female)
MBCC-308	1.83 m (6 ft)	Straight		
MBCC-312	3.66 m (12 ft)			
MBCC-330	9.14 m (30 ft)			
4-Pin Single-Ended 7/8-in Female Cordsets				
Model	Length	Style	Dimensions	Pinout (Female)
MBCC-408	1.83 m (6 ft)	Straight		
MBCC-412	3.66 m (12 ft)			
MBCC-430	9.14 m (30 ft)			

Cabling Accessories

Model	Description	
AC-6	2 m (6.5 ft) armored cable jacket	I.D. 5/16-in; O.D. 7/16-in
PVC-6	2 m (6.5 ft) flexible PVC tubing (not for QD models)	I.D. 1/4-in; O.D. 3/8-in
RF1-2NPS	Compression fitting for attaching armored cable or PVC tubing	-

Continued on page 11

Continued from page 10

Model	Description
HF1-2NPS	<ul style="list-style-type: none"> • Flexible black nylon cable protector • Includes a neoprene gland that compresses around the VALU-BEAM cable to provide an additional seal against moisture • Resistant to gasoline, alcohol, oil, grease, solvents and weak acids • Working temperature range of $-30\text{ }^{\circ}\text{C}$ to $+100\text{ }^{\circ}\text{C}$ ($-22\text{ }^{\circ}\text{F}$ to $+212\text{ }^{\circ}\text{F}$)

Extension Cables (without connectors)

The following cables are available for extending the length of the existing sensor cable. These are 30 m (100 ft) lengths of VALU-BEAM cable. This cable may be spliced to an existing cable. Connectors, if used, must be customer-supplied.

Model	Type	Used With:
EC312-100	4-conductor	SM912 Series DC sensors
EC312A-100	2-conductor	For all emitters and SM2A912 Series AC sensors

Retroreflective Targets

Banner offers a wide selection of high-quality retroreflective targets. See www.bannerengineering.com for complete information.

NOTE: Polarized sensors require corner cube-type retroreflective targets. Non-polarized sensors may use any retroreflective target.



Replacement Lens Assemblies

VALU-BEAM lens assemblies are field-replaceable. In addition, some lenses may be used to convert from one sensing mode to another, or to change the sensing range of a particular sensor. The possible conversions are listed in the table below.

Models	Description	Possible Sensing Mode or Range Changes
UC-900AG	Replacement lens for LVAG	Change LV to LVAG
UC-900C	Replacement lens for C and CV	Change LV to CV
UC-900DSR	Replacement lens for DSR, ESR, and RSR	Change D or F to DSR, EF to ESR, and RF to RSR
UC-900F	Replacement lens for F	Change D to F and DSR to F
UC-900FP	Replacement lens for FP	-
UC-900L	Replacement lens for E, R, LV, and D	Change LVAG to LV, CV to LV, DSR to D, and F to D
UC-900J	Attach to E, R, ESR, RSR, LV, and D models	Flat polycarbonate dust cover

Mounting Brackets

SMB30C

- 30 mm split clamp, black PBT bracket
- Stainless steel mounting hardware included
- Mounting hole for 30 mm sensor

Hole center spacing: $A = \varnothing 45$
 Hole size: $B = \varnothing 27.2$

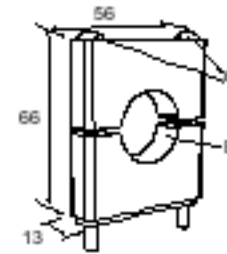

SMB30SC

- Swivel bracket with 30 mm mounting hole for sensor
- Black reinforced thermoplastic polyester
- Stainless steel mounting and swivel locking hardware included

Hole center spacing: $A = \varnothing 50.8$
 Hole size: $A = \varnothing 7.0$, $B = \varnothing 30.0$

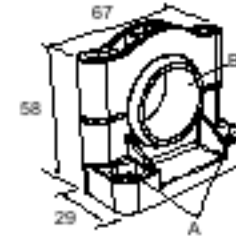

SMB30MM

- 12-gauge stainless steel bracket with curved mounting slots for versatile orientation
- Clearance for M6 (1/4 in) hardware
- Mounting hole for 30 mm sensor

Hole center spacing: $A = 51$, A to $B = 25.4$
 Hole size: $A = 42.6 \times 7$, $B = \varnothing 6.4$, $C = \varnothing 30.1$

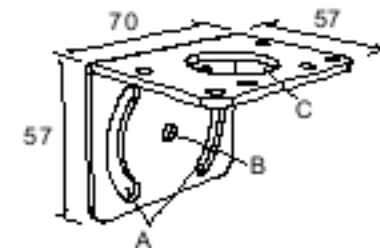

Banner Engineering Corp Limited Warranty

Banner Engineering Corp. warrants its products to be free from defects in material and workmanship for one year following the date of shipment. Banner Engineering Corp. will repair or replace, free of charge, any product of its manufacture which, at the time it is returned to the factory, is found to have been defective during the warranty period. This warranty does not cover damage or liability for misuse, abuse, or the improper application or installation of the Banner product.

THIS LIMITED WARRANTY IS EXCLUSIVE AND IN LIEU OF ALL OTHER WARRANTIES WHETHER EXPRESS OR IMPLIED (INCLUDING, WITHOUT LIMITATION, ANY WARRANTY OF MERCHANTABILITY OR FITNESS FOR A PARTICULAR PURPOSE), AND WHETHER ARISING UNDER COURSE OF PERFORMANCE, COURSE OF DEALING OR TRADE USAGE.

This Warranty is exclusive and limited to repair or, at the discretion of Banner Engineering Corp., replacement. IN NO EVENT SHALL BANNER ENGINEERING CORP. BE LIABLE TO BUYER OR ANY OTHER PERSON OR ENTITY FOR ANY EXTRA COSTS, EXPENSES, LOSSES, LOSS OF PROFITS, OR ANY INCIDENTAL, CONSEQUENTIAL OR SPECIAL DAMAGES RESULTING FROM ANY PRODUCT DEFECT OR FROM THE USE OR INABILITY TO USE THE PRODUCT, WHETHER ARISING IN CONTRACT OR WARRANTY, STATUTE, TORT, STRICT LIABILITY, NEGLIGENCE, OR OTHERWISE.

Banner Engineering Corp. reserves the right to change, modify or improve the design of the product without assuming any obligations or liabilities relating to any product previously manufactured by Banner Engineering Corp. Any misuse, abuse, or improper application or installation of this product or use of the product for personal protection applications when the product is identified as not intended for such purposes will void the product warranty. Any modifications to this product without prior express approval by Banner Engineering Corp will void the product warranties. All specifications published in this document are subject to change; Banner reserves the right to modify product specifications or update documentation at any time. Specifications and product information in English supersede that which is provided in any other language. For the most recent version of any documentation, refer to: www.bannerengineering.com.

For patent information, see www.bannerengineering.com/patents.