

To Be Performed at Every Power-up, Shift Change, and Machine Setup:

For a detailed description of this procedure, see section 6.3 of your user's manual.

Daily checkout and checkouts after tooling and machine changes must be performed by a Designated Person (appointed and identified in writing by the employer). During continuous machine run periods, this checkout must be performed at regular intervals. A copy of the checkout results should be kept on or near the machine: see OSHA 1910.217(e)(1).

✓ **The Designated Person must:**

- 1) **Verify that access to the dangerous parts of the guarded machine is not possible** from any direction not protected by the MINI-SCREEN System or supplemental guarding.
- 2) **Verify that the minimum distance** from the closest hazard point of the guarded machine to the light screen is not less than the calculated distance.

Calculated Distance

To be entered by a Qualified Person (as defined by ANSI B30.2-1983) at the time of installation or semi-annual checkout. See manual, section 3.2.1 for more information.

- 3) **Verify that it is not possible for a person to stand inside the guarded (dangerous) area, undetected by the MINI-SCREEN System or other supplemental guarding.**
Verify that hard guarding is in place and working properly to prevent access to the hazard in any area being ignored by fixed blanking.
- 4) **Verify that the MINI-SCREEN control box cover is latched and locked.** The key (or combination or tool) to the lock should be in the possession of a Qualified Person.
- 5) **Test the effectiveness of the MINI-SCREEN system with power ON,** using the chart below to select the proper test piece for your system configuration:

Floating Blanking Program	Specified Test Piece	
	Standard Models	Long-Range Models
None (OFF)	STP-2, 19.1 mm (0.75")	STP-7, 25.4 mm (1.00")
1-beam	STP-4, 31.8 mm (1.25")	STP-1, 38.1 mm (1.50")
2-beam	STP-3, 44.5 mm (1.75")	STP-8, 50.8 mm (2.00")

Specified Test Piece

- 5a) **Verify that the MINI-SCREEN System is in RUN mode:**
 - Green and yellow System status indicators – ON.
(Green will flash if blanking is ON.)

If the Auto Power-up feature is OFF when power is applied to the System, it is normal for it to power up into a Lockout condition. If this occurs, perform a Key Reset.

Verify that the Muting function is not enabled.

- 5b) **Trip Test. With the guarded machine at rest,** pass the selected test piece downward through the light screen at three points, perpendicular to the light screen: near the receiver, near the emitter, and midway between them (see Figure, right).

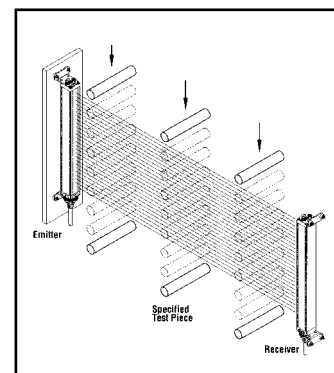

Verify when test piece is in the light screen:

- Red Light Screen Status indicator – ON

MINI-SCREEN System trip test

Verify when test piece is removed from the light screen:

- Green Light Screen Status indicator – ON (flashing if blanking is ON)

Perform a system Key Reset to reset the latch after each pass of the test piece.

If the green indicator comes ON at any time when the test piece is in the light screen, check for reflective surfaces and unguarded areas created by use of fixed blanking. **Do not continue until the cause is discovered and the situation is resolved. On latching models, perform a System Key Reset to reset the latch after each pass of the test piece.**

- 5c) **With the guarded machine moving,** insert the test piece into the light screen (perpendicular to it). **Do not attempt to insert the test piece into the dangerous parts of the machine.**

Verify when test piece enters light screen:

Machine dangerous motion stops without apparent delay.

Verify when test piece is removed from light screen (and latch reset is performed on latching models): Machine does not automatically restart (initiation devices must be engaged to restart the machine).

- 5d) **With the guarded machine at rest,** insert the test piece into the light screen.

Verify when the test piece is in the light screen: the guarded machine cannot move.

- 6) **Check carefully for external signs of damage to the MINI-SCREEN System,** the guarded machine, and their electrical wiring. Any damage found should be reported immediately to management.

- 7) **If the Muting feature is used:**
- 7a) Verify that the mute devices are intact and operating properly.
 - 7b) Initiate a normal mute cycle.
 - 7c) Verify that the Mute indicator comes ON.
 - 7d) **Interrupt the safety light screen with the test piece selected in step 5. Verify:**
 - Red Light Screen status indicator – comes ON
 - Green Light Screen indicator – OFF
 - Yellow Light Screen indicator – Flashing or OFF
 - Green and yellow System status indicators – ON

If the 30-second or 60-second Backdoor Timer feature is selected, the System Diagnostic Display will begin to count down; otherwise a flashing dash will appear on the display.
 - 7e) **Clear the safety light screen (before the Backdoor Timer expires) and verify:**
 - Green and yellow Light Screen status indicators – ON

Clear (or deactivate) the mute devices and verify:

 - Mute indicator – OFF
 - Green and yellow System status indicators – ON
 - 7f) Verify that it is not possible for a single individual to trigger the mute devices (block both photoelectric beams or actuate both switches) to initiate a mute and then pass through the defined area without being detected and a subsequent stop command being issued to the machine. **Do not expose any individual to hazard while attempting to initiate a mute cycle.**
 - 7g) Verify that it is not possible for personnel to pass in front of, behind, or next to the muted object without being detected and a subsequent stop command being issued to the machine.
 - 7h) If One-Way (directional) Muting is selected, verify that a mute cycle can not be initiated by blocking (or activating) muting devices M3 and M4 before M1 and M2. **Do not expose any individual to hazard while attempting to initiate a mute cycle.**
- 8) **If the Override feature is used:**
- 8a) Ensure that the positioning of the Override switches allows the operator full view of the hazardous area and the area being guarded by the safety light screen. Verify that the location is not within reach from inside the safeguarded space.
 - 8b) **With muting de-activated, interrupt the safety light screen with the test piece selected in step 5. Verify:**
 - Red Light Screen status indicator – comes ON
 - Green Light Screen indicator – OFF
 - Yellow Light Screen indicator – Flashing
 - Green System status indicator – OFF
 - Yellow System status indicator – ON
 - 8c) Three seconds after interrupting the light screen, initiate an override cycle: turn both Override switches to ON simultaneously (hold in the ON position if necessary).
 - 8d) **While the light screen is interrupted, verify:**
 - Both red status indicators – ON
 - Yellow Light Screen indicator – Flashing (rate proportional to number of clear beams)
 - Green System status indicator – ON
 - FSDs – closed
 - 8e) Verify that the Override drops out after 10 seconds. To initiate another override cycle, return switches to the OFF (open) condition, wait 3 seconds, and then simultaneously re-close the Override switches.
 - 8f) **Perform a System Key Reset. Verify:**
 - Green and yellow System status indicators – ON
 - FSDs – closed

If one or both red status indicator(s) begins to flash when the system goes into RUN mode, an internal lockout condition exists. Refer to Section 5.1 of the manual to determine the cause of the lockout.
- 9) **If all checks cannot be verified, shut machine down and do not use until the problem(s) has been corrected. Refer to user's manual, Section 5.**



WARNING . . . Do Not Use Machine If the System Does Not Check Out

If all of these checks cannot be verified, do not use the MINI-SCREEN System/guarded machine until the defect or problem has been corrected (see Section 5 of the manual). **Doing so could result in serious bodily injury or death.**