



the machine safety specialist

MINI-SCREEN® DIN Control Modules with Removeable Wiring Blocks

Supplement to MINI-SCREEN Instruction Manual 44895

MINI-SCREEN controllers with removeable wiring blocks are identical to the models with permanent wiring blocks, except for the removeable wiring blocks. With the removeable wiring blocks, wiring terminal numbers change and one overall controller dimension increases. This supplement modifies the information for Figures 17, 20, and 23 which appear in MINI-SCREEN manual 44895.

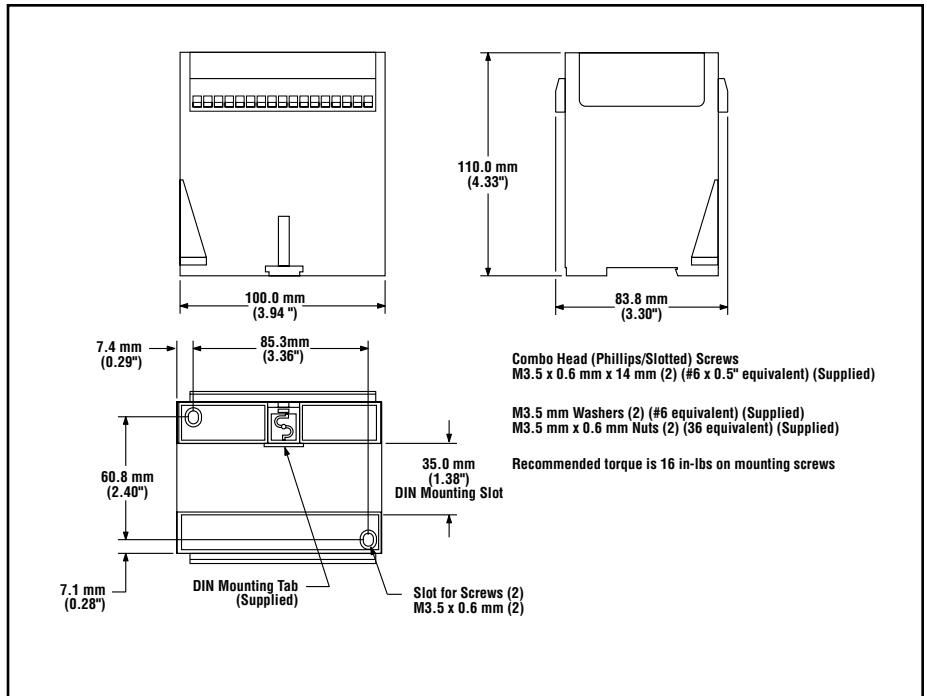

Figure 17. Control Module Dimensions and Mounting Hole Locations.

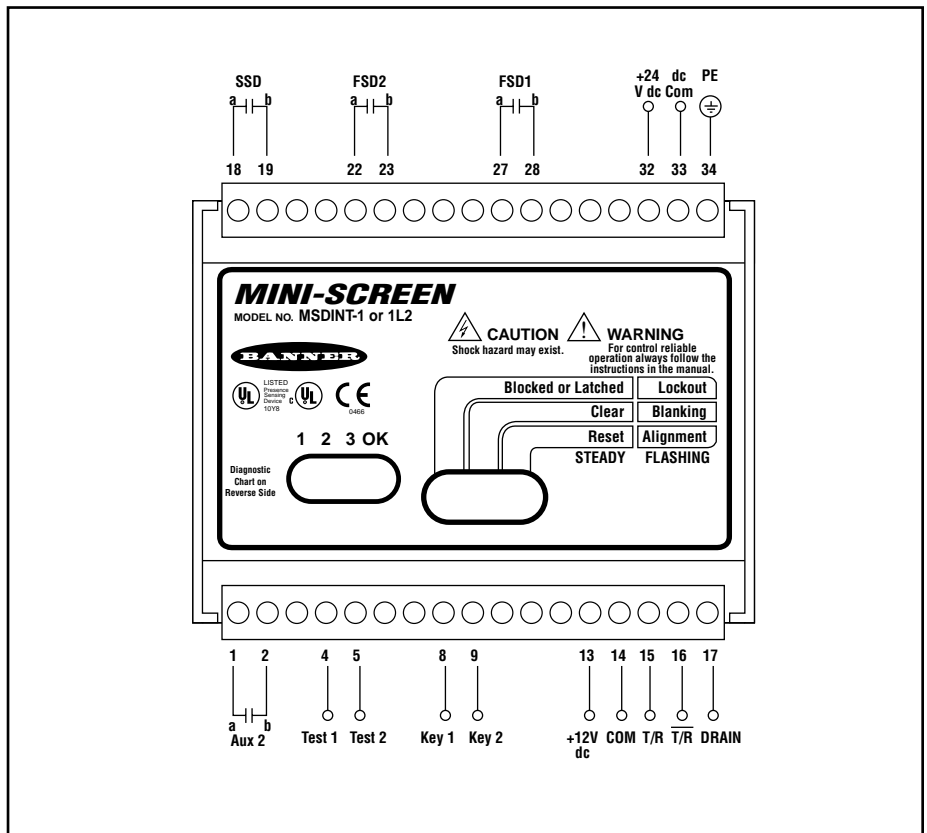

Figure 20. MINI-SCREEN System electrical connections.

MSDINT-1 or MSDINT-1L2



WARNING . . .
Use of MINI-SCREEN
Systems for Perimeter
Guarding

If a trip control module is used for perimeter guarding, the Machine Primary Control Elements (MPCEs) of the guarded machine must be wired so that the trip output of the control module causes a latched response of the MPCEs. The MPCEs must be reset **only** by actuation of a reset switch.

The reset switch must be located outside of the area of dangerous motion, and must be positioned so that the area of the dangerous motion may be observed by the switch operator during the reset operation. Supplemental presence sensing devices, such as safety mats, must be used if any space between the defined area and any danger point is large enough to allow a person to stand undetected by the MINI-SCREEN System. Failure to observe this warning could result in serious bodily injury or death.

Figure 23 (below) shows output relay connections in a generic interfacing situation. The connections between the MINI-SCREEN System outputs and the machine primary and secondary control elements must be direct, and arranged so that any single line fault or earth fault will not result in a circuit failure to a potentially dangerous state.

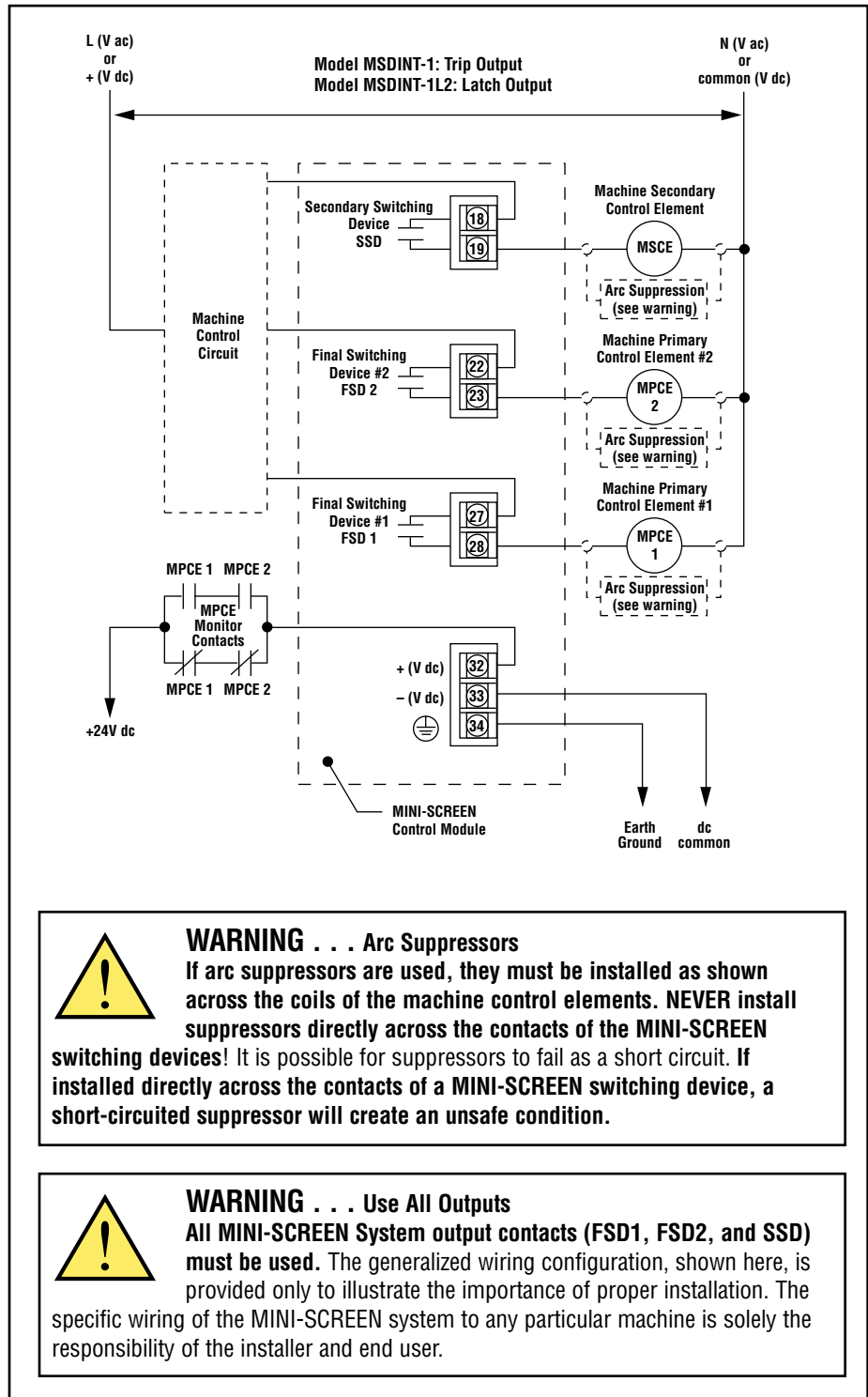

WARNING . . . Arc Suppressors

If arc suppressors are used, they must be installed as shown across the coils of the machine control elements. **NEVER** install suppressors directly across the contacts of the MINI-SCREEN switching devices! It is possible for suppressors to fail as a short circuit. If installed directly across the contacts of a MINI-SCREEN switching device, a short-circuited suppressor will create an unsafe condition.



WARNING . . . Use All Outputs

All MINI-SCREEN System output contacts (FSD1, FSD2, and SSD) must be used. The generalized wiring configuration, shown here, is provided only to illustrate the importance of proper installation. The specific wiring of the MINI-SCREEN system to any particular machine is solely the responsibility of the installer and end user.

Figure 23. Generic machine interface, MINI-SCREEN System