



# MINI-SCREEN<sup>®</sup> System

## Instruction Manual

- An optoelectronic point-of-operation guarding device for production machinery such as hydraulic and pneumatic power presses, molding presses, and automated production equipment
- Compact package for smaller production machines
- Creates a curtain of synchronized, modulated infrared sensing beams from 4 inches to 4 feet high (in 12 different length increments). Sensors are available with choice of black or safety yellow finish and with sensing range of either 9 m (30 ft) or 18 m (60 ft), depending on models selected (see page 6).
- Remote TEST input terminals for simulating a "blocked" condition
- Replaceable redundant output relays with "forced guided" contacts to ensure control reliability
- Features floating blanking, which is easily configured inside the lockable control box
- FMEA tested to ensure control reliability
- Highly visible LEDs on control box and receiver give system status and emitter/receiver alignment indications; system diagnostic LEDs visible through transparent window in control box cover
- Controller uses "diverse redundancy" design concept to achieve a higher level of control reliability
- Highly immune to EMI, RFI, ambient light, weld flash, and strobe light
- Modular design with no "matched sets" necessary: any emitter and receiver (of equal length) and any control box may be used together
- Vibration-tolerant factory burned-in emitter and receiver circuitry for toughness and dependability
- Swivel mounting brackets and small, light-weight tubular sensors for quick installation and ease of alignment both on new equipment and in retrofit applications; anti-vibration mounts provided



LISTED  
Presence  
Sensing  
Device  
10Y8



Certified in  
compliance with  
British Standard  
BS6491 Parts I & II

IEC 1496-1, -2  
EN 50100-1, -2



## Applications and Limitations of MINI-SCREEN® Systems

**MINI-SCREEN Systems are typically used in the following applications:**

- Hydraulic and pneumatic power presses
- Molding presses
- Automated production equipment

**MINI-SCREEN Systems may NOT be used with the following machinery:**

Any machine that cannot be stopped immediately after a stop signal is issued, such as single stroke (also known as “full-revolution”) clutched machinery.

Any machine with inadequate or inconsistent machine response time and stopping performance.

Any machine that ejects materials or component parts through the defined area.

MINI-SCREEN Systems may not be used in any environment that is likely to adversely affect the efficiency of a photoelectric sensing system. For example, corrosive chemicals or fluids or unusually severe levels of smoke or dust, if not controlled, may degrade the efficiency of Banner MINI-SCREEN Systems.

**Banner MINI-SCREEN Systems may not be used as tripping devices to initiate machine motion (PSDI applications) on mechanical power presses, per OSHA regulation 29 CFR 1910.217.**

Banner Engineering Corp.  
9714 - 10th Avenue No.  
Minneapolis, MN 55441  
Telephone: (612) 544-3164  
FAX: (applications) (612) 544-3573

## Important... read this page first!

In the United States, the *functions* that Banner MINI-SCREEN® Systems are intended to perform are regulated by the Occupational Safety and Health Administration (OSHA). However, whether or not any particular MINI-SCREEN System *installation* meets all applicable OSHA requirements depends upon factors that are beyond the control of Banner Engineering Corporation. These factors include the details of how the MINI-SCREEN System is applied, installed, wired, operated, and maintained.

Banner Engineering Corp. has attempted to provide complete application, installation, operation, and maintenance instructions. In addition, we suggest that any questions regarding application or use of MINI-SCREEN Systems be directed to the factory applications department at the telephone numbers or address shown at the bottom of this page.

Banner MINI-SCREEN Systems can guard against accidents *only* when they are properly installed and integrated into the machine, properly operated, and properly maintained. See Section 3 of this manual for installation procedures, considerations, and precautions. See Sections 4 and 5 for operating and maintenance information. It is the responsibility of the purchaser and/or user to apply this MINI-SCREEN System in full compliance with OSHA regulations.

**The user of the MINI-SCREEN System shall ensure that all machine operators, maintenance personnel, electricians, and supervisors are thoroughly familiar with and understand all instructions regarding the use and maintenance of the MINI-SCREEN System and the machinery upon which it is installed, as well as all appropriate safety regulations. Failure to follow all instructions or warnings could result in serious bodily injury or death.**

In addition to OSHA regulations, several other organizations provide informational material on the use of machine guard devices. The user is referred to the American National Standards Institute (ANSI), the Robotics Institute of America (RIA), the American Metal Stamping Association (AMSA), and others. Banner Engineering Corp. makes no claim regarding a specific recommendation of any organization, the accuracy or effectiveness of any information provided, or the appropriateness of the provided information for a specific application.

The user has the responsibility to ensure that all local, state, and national laws, rules, codes, and regulations relating to the use of this machine guarding system in any particular application are satisfied. Extreme care is urged to ensure that all legal requirements have been met and that all installation and maintenance instructions contained in this manual are followed.

## Caution!!

Banner MINI-SCREEN® Systems are for use only on machinery that can be stopped immediately after a stop signal is issued. They may be used with part-revolution clutched machines that have the ability to stop at any point in their stroke. *Under no circumstances may the MINI-SCREEN System be used on full-revolution clutched machinery. Banner MINI-SCREEN Systems may not be used as tripping devices to initiate machine motion (PSDI applications) on mechanical power presses, per OSHA regulation 29 CFR 1910.217.*

### U.S. Standards Applicable to Use of MINI-SCREEN® Systems

ANSI B11.1 through B11.20 .....*Safeguarding of Machine Tools*

ANSI/RIA 15.06 .....*Safety Requirements for Robot Systems*

Copies are available from:

Safety Director  
National Machine Tool Builders Association  
7901 Westpark Drive  
McLean, VA 22101-4269

*See page 57 for information on these and other applicable standards, and where to acquire copies.*

## Table of Contents

Important Information .....	page 2
<b>1. MINI-SCREEN System Introduction .....</b>	<b>page 4</b>
1.1 MINI-SCREEN Components and Kits .....	page 6
<b>2. Overview of MINI-SCREEN Operation .....</b>	<b>page 7</b>
2.1 Blanking .....	page 7
2.2 Auto Power-up .....	page 7
2.3 Lockout Conditions and Key Resets .....	page 8
2.4 Operating Status Indicator Lights .....	page 9
2.5 Diagnostic Indicator LEDs .....	page 10
2.6 Output Relay Operation .....	page 11
2.7 Control Reliability: Redundancy and Self-Checking .....	page 12
<b>3. System Installation and Alignment .....</b>	<b>page 13</b>
3.1 Appropriate Application .....	page 13
3.2 Mechanical Installation Considerations .....	page 14
3.2.1 Separation Distance .....	page 14
3.2.2 Hard Guarding .....	page 16
3.2.3 Emitter and Receiver Orientation .....	page 17
3.2.4 Adjacent Reflective Surfaces .....	page 18
3.2.5 Use of Corner Mirrors .....	page 18
3.2.6 Installation of Multiple MINI-SCREEN Systems .....	page 19
3.3 Mounting Procedure .....	page 20
3.4 Controller Module Configuration .....	page 23
3.5 Electrical Hookup and Checkouts .....	page 24
3.5.1 Emitter and Receiver Hookup .....	page 25
3.5.2 System Power (temporary connection) .....	page 26
3.5.3 MINI-SCREEN System Initial Checkout .....	page 26
3.5.4 Output Relay Connections .....	page 29
3.5.5 System Power (permanent connection) .....	page 31
3.5.6 Auxiliary Monitor Relay .....	page 31
3.5.7 Accessory Connections .....	page 31
<b>4. Operating Instructions .....</b>	<b>page 32</b>
4.1 Security Protocol .....	page 32
4.2 Periodic Checkout Requirements .....	page 32
4.3 Normal Operation .....	page 33
<b>5. Troubleshooting and Maintenance .....</b>	<b>page 34</b>
5.1 Troubleshooting Lockout Conditions .....	page 34
5.2 Effects of Electrical and Optical Noise .....	page 36
5.3 Servicing and Maintenance .....	page 36
5.3.1 Fuse Testing and Replacement .....	page 36
5.3.2 Controller Module and Relay Replacement .....	page 36
5.3.3 Cleaning .....	page 37
<b>6. Alignment and Checkout Procedures .....</b>	<b>page 38</b>
6.1 MINI-SCREEN System Alignment .....	page 38
6.2 Commissioning Checkout .....	page 42
6.3 Shift Change & Machine Setup Change Checkout .....	page 44
6.4 Semi-annual Checkout .....	page 45
Initial Checkout: MINI-SCREEN System only .....	page 26
<b>Glossary of Terms .....</b>	<b>page 46</b>
Specifications .....	page 52
Models and Ordering Information .....	page 54
Replacement Parts .....	page 57
Standards Information .....	page 59

## 1. MINI-SCREEN System Introduction

The Banner MINI-SCREEN System is a microprocessor-controlled opposed mode opto-electronic "curtain of light". It is designed for use as a point-of-operation guarding device, and is especially suited to smaller production machinery.

Banner's microprocessor-based circuit establishes a higher level of control reliability in machine guard design. The MINI-SCREEN System uses the design concept of "diverse redundancy", in which two microprocessors of different design, running from two different instruction sets, constantly check all system components, including each other. Banner MINI-SCREEN Systems are extensively FMEA (Failure Mode and Effects Analysis) tested to establish an extremely high degree of confidence that no system component will ever, even if it does fail, cause a *failure to danger*.

In typical operation, if any part of an operator's body (or any opaque object) of more than a certain cross section enters the guarded area of the machine, the output relays of the MINI-SCREEN System will open. The contacts of the output relays are connected to the guarded machine's primary control elements (MPCEs) which immediately stop the motion of the guarded machine. The output relays have forced-guided contacts for enhanced control reliability.

The *floating blanking* feature of the MINI-SCREEN System allows for the movement of multiple workpieces through the curtain at any point. Use of floating blanking affects the *minimum object sensitivity* (see section 2.1).

The Banner MINI-SCREEN is a modular machine guard system. Each system is made up of an MSE Series emitter unit, an MSR Series receiver unit, and a model MSCA-1, MSCB-1 or MSCT-1 control box (see Figure 1 and cover photo). The three MINI-SCREEN System components are interconnected using two 5-wire shielded cables with QD (Quick Disconnect) connectors on their emitter and receiver ends.

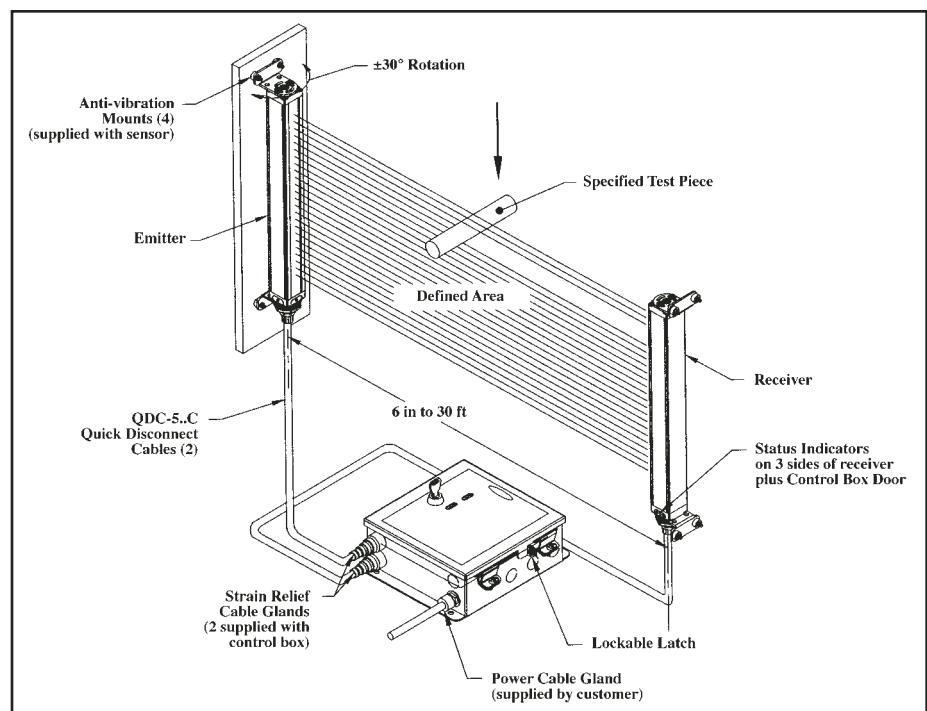

Figure 1. Banner MINI-SCREEN System: emitter, receiver, control box, and two interconnecting cables.

Emitter units consist of a row of synchronized modulated infrared (invisible) light emitting diodes (LEDs) in a compact rectangular metal housing. Receiver units consist of a corresponding row of synchronized phototransistors. Emitters and receivers are available in various sizes (based on the height of the defined area), in 12 lengths ranging from 4 inches to 4 feet (see page 6). The rectangular sensor design includes a swivel bracket at each end for quick mounting and ease of alignment. Control boxes and receivers have LED indicators for system operating status and alignment. Each receiver has three sets of status LEDs (front and both sides) for high visibility. Emitters have POWER ON indicators.

MINI-SCREEN emitters and receivers are available with the choice of two sensing ranges (maximum emitter-to-receiver separation): 9 meters (30 feet) or 18 meters (60 feet). The *minimum object sensitivity* of 30-foot range sensor pairs is 19 millimeters (0.75 inch) with no blanking in use. The *minimum object sensitivity* of 60-foot range sensor pairs is 25 millimeters (1.0 inch) with no blanking in use.

The control box contains a power supply (to power the control box itself and an emitter and receiver), a microprocessor controller module to control sensing logic, and a replaceable relay board with forced-guided output relays. Diagnostic LEDs on the controller module (visible through a clear window in the control box cover) identify eight trouble causes. There is a keyed panel switch for resetting the system at power-up or from fault (lockout) conditions.

The *minimum object sensitivity* is the minimum-diameter object that the light screen can reliably detect anywhere within the defined area. *Minimum object sensitivity* directly affects the minimum allowable distance between the *defined area* of the light screen and the nearest hazard point (i. e. - the *separation distance*). See Section 3.2.

The selectable auto power-up feature makes a key reset at system power-up unnecessary for those applications where a key reset is difficult to perform.

Banner MINI-SCREEN Systems are designed for convenient and dependable operation in difficult industrial environments. The microprocessor controller module has a plug-in design for easy configuring or replacement. The output relay module is easily replaceable. The control box enclosure is rated NEMA 13 (IP 64) and features a lockable cover.

Emitter and receiver circuits are designed to meet high standards for vibration resistance. Every MINI-SCREEN System emitter, receiver, and controller module is serialized and undergoes extensive burn-in testing at the factory.

Any MINI-SCREEN System emitter and receiver (of equal length) may be used together with any control box. Unlike some competitive systems, matched sets are *not* required.

A functional schematic diagram of the MINI-SCREEN System appears on page 11. For MINI-SCREEN System dimension drawings, see pages 21 and 22. For specifications, see page 52.

The components of a MINI-SCREEN system may be purchased separately, or they may be purchased bundled together in kit form. The components and kits are listed on the next page.



#### WARNING . . .

The MINI-SCREEN System uses **one pair** of sensors connected to **one** control module. Connection of multiple pairs of sensors to a single control module can result in serious bodily injury or death, and is prohibited.

NOTE: Banner **MULTI-SCREEN®** and **Dual MINI-SCREEN®** Systems are designed for connection of two sensor pairs.

# System Introduction

## 1.1 MINI-SCREEN Components and Kits

MINI-SCREEN Systems are sold as kits which include a control box, an emitter and receiver of equal length, emitter and receiver mounting hardware, and two quick-disconnect cables (see page 55 and 56). Cables are interchangeable between the emitter and the receiver. Components are also available separately (below).

MINI-SCREEN Emitters (E) and Receivers (R)				
Defined Area	Models			Number of Beams
	Black Anodized	Yellow Painted		
	Range - 9 m (30 ft)	Range - 9 m (30 ft)	Range - 18 m (60 ft)	
114 mm (4.5 in)	MSE424 MSR424	MSE424Y MSR424Y	MSXLE424Y MSXLR424Y	8
215 mm (8.5 in)	MSE824 MSR824	MSE824Y MSR824Y	MSXLE824Y MSXLR824Y	16
305 mm (12 in)	MSE1224 MSR1224	MSE1224Y MSR1224Y	MSXLE1224Y MSXLR1224Y	24
406 mm (16 in)	MSE1624 MSR1624	MSE1624Y MSR1624Y	MSXLE1624Y MSXLR1624Y	32
508 mm (20 in)	MSE2024 MSR2024	MSE2024Y MSR2024Y	MSXLE2024Y MSXLR2024Y	40
610 mm (24 in)	MSE2424 MSR2424	MSE2424Y MSR2424Y	MSXLE2424Y MSXLR2424Y	48
711 mm (28 in)	MSE2824 MSR2824	MSE2824Y MSR2824Y	MSXLE2824Y MSXLR2824Y	56
813 mm (32 in)	MSE3224 MSR3224	MSE3224Y MSR3224Y	MSXLE3224Y MSXLR3224Y	64
914 mm (36 in)	MSE3624 MSR3624	MSE3624Y MSR3624Y	MSXLE3624Y MSXLR3624Y	72
1016 mm (40 in)	MSE4024 MSR4024	MSE4024Y MSR4024Y	MSXLE4024Y MSXLR4024Y	80
1118 mm (44 in)	MSE4424 MSR4424	MSE4424Y MSR4424Y	MSXLE4424Y MSXLR4424Y	88
1219 mm (48 in)	MSE4824 MSR4824	MSE4824Y MSR4824Y	MSXLE4824Y MSXLR4824Y	96

## Control Boxes

<b>MSCA-1</b>	115V ac control box (One per system)
<b>MSCB-1</b>	230V ac control box (One per system)
<b>MSCT-1</b>	24V dc control box (One per system)

## Cables (Two required per system)\*

<b>QDC-515C</b>	4.5 m (15 ft) cable, straight QD connector. One cable per sensor.
<b>QDC-525C</b>	7.6 m (25 ft) cable, straight QD connector. One cable per sensor.
<b>QDC-550C</b>	15 m (50 ft) cable*, straight QD connector. One cable per sensor.

\* Contact factory Applications Department for information on cable lengths greater than 50 feet.

### Pigtail Quick Disconnect Option

Any yellow emitter or receiver may be ordered with a 305 mm (12 in) cable pigtail terminated in the 5-pin male mini-style quick disconnect connector. This option accommodates requirements for right-angle exit of the cable from the base of the emitter and receiver. The same mating quick disconnect cables, as listed above, are used (ordered separately). To specify a pigtail quick disconnect cable, add suffix "P" to the model number of the emitter or receiver, for example: **MSE1624YP**.

## 2. Overview of MINI-SCREEN System Operation

In operation, an emitter and receiver (of equal length) are mounted and aligned opposite each other. This establishes a curtain of invisible infrared light beams called the *defined area* (Figure 1). Center-to-center spacing between adjacent light beams is 0.5 inch (12,7 mm).

The following features of the MINI-SCREEN System are discussed in the listed subsections:

- Blanking (Section 2.1)
- Auto power-up (Section 2.2)
- Lockout Conditions and Key Resets (Section 2.3)
- Operating Status Indicator Lights (Section 2.4)
- Diagnostic Indicator LEDs (Section 2.5)
- Output Relay Operation (Section 2.6)
- Control Reliability: Redundancy & Self-checking (Section 2.7)

### 2.1 Blanking

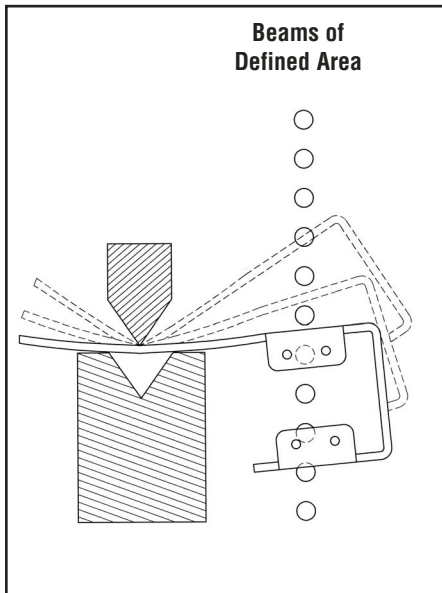

Figure 2. Two-Beam Floating Blanking

\*NOTE: This assumes that the object encounters the curtain perpendicular to the plane of the light beams.

MINI-SCREEN Systems may be configured to be "blind" to the passage of multiple objects of limited size through the defined area. This is useful in press brake and other applications where multiple blanked zones (moveable or stationary) are needed. NOTE: Blanking "on" is indicated by a flashing green receiver or control box Status Indicator LED.

*Floating blanking* is the "blinding" of groups of two adjacent sensing beams, which will appear to change position ("float") in order to allow multiple objects (usually workpiece material) to move through the defined area, at any point, without tripping the final switching device relays of the MINI-SCREEN System. *With floating blanking "on", any and every one- or two-beam blockage(s) will be ignored.* See Figure 2.

Sensor Type	Floating Blanking	Maximum Size of Undetected Objects	Minimum Object Sensitivity
9 m (30 ft) range	Off	(Not applicable)	19.1 mm (0.75 in)
	On	20.3 mm (0.80 in)*	44.5 mm (1.75 in)
18 m (60 ft) range	Off	(Not applicable)	25.4 mm (1.00 in)
	On	16.5 mm (0.65)*	50.8 mm (2.00 in)

Floating blanking preference ("on" or "off") is set via a pair of DIP switches on the controller module inside the control box (see Figure 18 and Section 3.4, both on page 23, for details). The control box is supplied with a lockable cover to prevent unauthorized access to the blanking settings.

### 2.2 Auto Power-up

Normal operation of the MINI-SCREEN System requires a key reset each time power is applied to the system. This is usually a desired response to a power failure or interrupt, and is required by some design standards. In applications where a key reset is difficult to perform, the auto power-up feature puts the MINI-SCREEN System directly into RUN mode when power is applied.

Auto power-up is enabled or disabled via a pair of DIP switches located on the controller module inside the control box. See Figure 18 and Section 3.4 on page 23 for details.

### 2.3 Lockout Conditions and Key Resets

A *lockout condition* of the MINI-SCREEN System causes *all* of its output relays to open, sending a "stop" signal to the guarded machine. A lockout condition will occur:

- 1) Upon "power-up" of the MINI-SCREEN System (unless Auto Power-up is "on"; see Figure 5, page 10),
- 2) If ac power to the MINI-SCREEN System is interrupted (unless Auto Power-up is "on"; see Figure 5),
- 3) If the control box key switch is in the RESET position, at power-up, (with auto power-up "on"); or if the key switch is switched to RESET while the system is in the RUN mode,
- 4) If an FSD (Final Switching Device - see Glossary) relay does not "drop out" within it's specified time,
- 5) If the SSD (Secondary Switching Device - see Glossary) relay has de-energized,
- 6) If the controller module switch settings are inconsistent with each other or if they are changed while the system is in the RUN mode, or
- 7) If the self-checking circuits of the microprocessor detect a component failure within the MINI-SCREEN System itself.

A lockout condition resulting from an internal system fault is indicated by a flashing red status indicator LED on the control box and the receiver unit. The green and yellow LEDs will be "off". See Fig. 5, page 10.

*Power-up/power interrupt lockouts* (Auto Power-up "off", conditions #1 and 2 above, yellow LED only double-flashing) are normal and require a *key reset* for operation to continue.

*Internal lockout conditions* (#3 through #6 above) result from component failures or incorrect controller settings, which must be corrected before the system will allow operation to continue (Section 2.7). Diagnostic Indicator LEDs (located inside the control box on the controller module, and visible through a window in the control box cover) will indicate the cause of the lockout (Section 2.5). Internal lockout conditions also require a RESET of the keyed switch on the control box cover (a *key reset*) to return the system to the RUN mode. A valid *key reset* consists of turning the key switch to the RESET position, holding it there for at least 1/2 second, and then returning the key switch to the RUN position.



## 2.4 Operating Status Indicator Lights

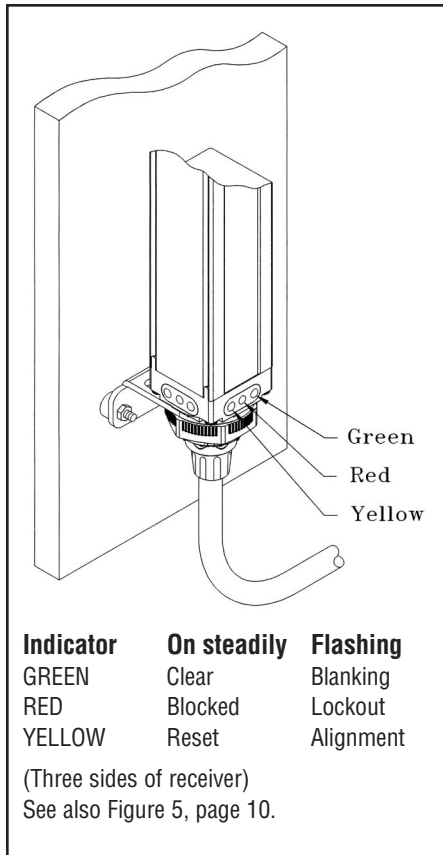

**Figure 3. Status Indicator LEDs (Receiver)**

The control box panel and the receiver have the following Operating Status Indicator LEDs (see Figure 3 and 4): green (CLEAR), red (BLOCKED), and yellow (RESET). Their indications are as follows:

**RED "on" steadily and YELLOW single-flashing\* (blocked condition):** the MINI-SCREEN System has been reset and is in the RUN mode, but either there is an obstruction in the defined area or the emitter and receiver are misaligned. FSD1, FSD2, and Auxiliary Monitor contacts are open (de-energized). SSD relay is closed (energized).

A flashing yellow LED indicates sensor alignment. The faster the flash rate, the more beams are "made", and the fewer beams are blocked or "not made". This feature is very helpful for emitter/receiver alignment (Section 6.1). When alignment is correct, the GREEN light will come "on" (to join YELLOW) and the RED light will go "off" when the obstruction is removed. If alignment is not correct, the GREEN light will remain "off" when the obstruction is removed.

**GREEN\*\* and YELLOW "on" steadily:** the MINI-SCREEN System has been reset and is in the RUN mode, the defined area is clear of obstructions, and the emitter and receiver are properly aligned. All output relays are closed.

**RED (only) "on" and flashing:** a lockout condition due to an internal MINI-SCREEN System problem exists. SSD, FSD1, FSD2, and Auxiliary Monitor contacts are all open (de-energized).

**YELLOW (only) "on" and double-flashing:** a *double-flashing* YELLOW LED indicates a power-up or power interrupt lockout condition. *These lockouts occur in the normal course of powering up the MINI-SCREEN System or upon an interruption of power to the System* (unless Auto Power-up is "on"; see Fig. 5). SSD, FSD1, FSD2, and Auxiliary Monitor contacts are open (de-energized).

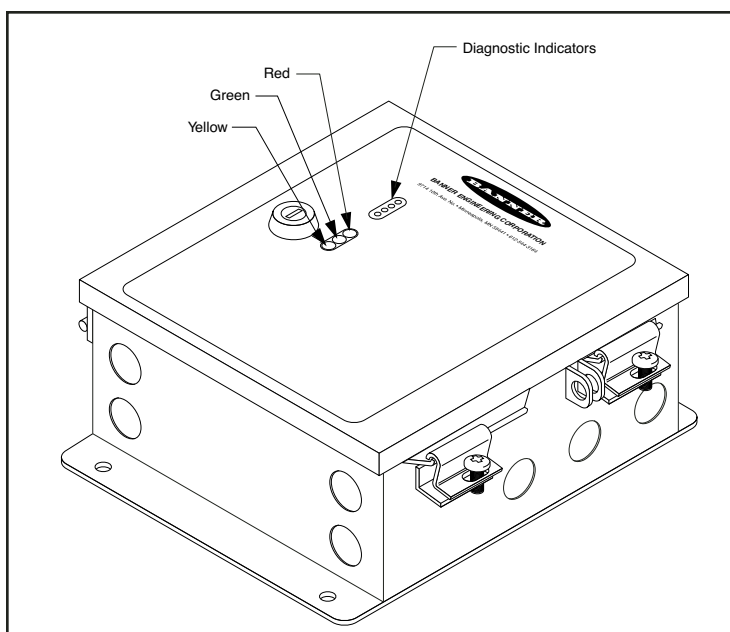

**Figure 4. Control Box Indicator LEDs**

**YELLOW (only) "on" steadily:** the key switch has been switched to the RESET position at power-up. FSD1, FSD2, and Auxiliary Monitor contacts are open (de-energized). SSD contacts are closed (energized).

\*If the TEST INPUT terminals are shorted, the YELLOW LED will be "on" steadily if the defined area is clear (see Section 3.5.7).

\*\*A flashing GREEN LED indicates the blanking is "on".

# System Overview

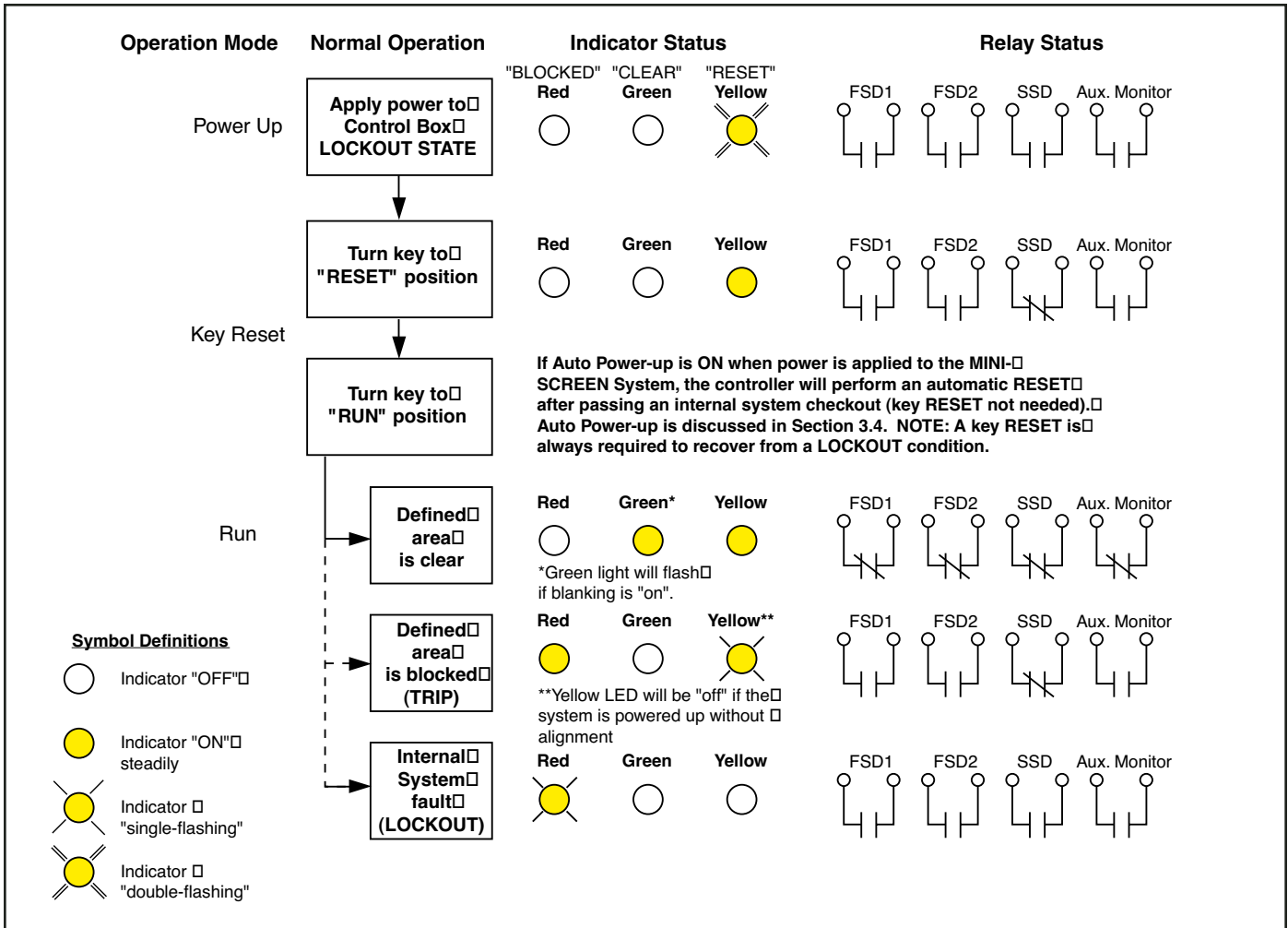

Figure 5. Operating Status Conditions

## 2.5 Diagnostic Indicator LEDs

There are four Diagnostic Indicator LEDs located on the edge of the controller module assembly. They are visible through a transparent window in the control box cover. Refer to Figure 4 (page 9).

The purpose of the Diagnostic Indicator LEDs is to assist in troubleshooting by indicating the possible causes of internal MINI-SCREEN System problems (lockouts) that are discovered as a result of the controller's self-checking function.

The green diagnostic indicator LED is always "on", as long as power is applied to the controller, except when a controller microprocessor has failed. The message of the four diagnostic indicator LEDs is interpreted using the table in Figure 24 (page 35).

## 2.6 Output Relay Operation

The MINI-SCREEN System control box has three output relays plus an Auxiliary Monitor Relay. Refer to Figure 6, below. The three output relays are labeled "FSD1", "FSD2", and "SSD". The contacts of the Final Switching Device (FSD) relays (FSD1 and FSD2) are connected to the Machine Primary Control Elements (MPCEs) of the guarded machine. An MPCE is an electrically powered element of the guarded machine that directly controls the machine's normal operating motion in such a way that it is last (in time) to operate when motion is either initiated or arrested. The Secondary Switching Device (SSD) relay contacts are connected to the guarded machine's Machine Secondary Control Element (MSCE), an electrically powered element of the guarded machine (independent of both MPCEs) that is capable of removing power from the prime mover of the dangerous part of the machine in the event of a system fault. The two MPCEs must each (alone) be capable of stopping the motion of the guarded machine in an emergency. The opening of any FSD1, FSD2, or SSD relay contact results in the removal of power to either an MPCE or MSCE (or both), which will stop the motion in the guarded machine.

Any object that blocks one or more unblanked beams will be detected, and will cause a trip condition: output relays FSD1 and FSD2 (but not SSD) in the control box open their contacts. All three output relays (FSD1, FSD2, and SSD) will open their contacts in response to any one or more of seven lockout conditions, including component failure within the MINI-SCREEN System itself (see Control Reliability, Section 2.7). The MINI-SCREEN System automatically resets itself from a trip condition when the object that caused the trip is removed, but recovery from a lockout condition requires a key reset (Section 2.3). NOTE: See warning regarding use of the MINI-SCREEN for perimeter guarding on page 13.

The Auxiliary Monitor Relay is a separate relay which follows the action of output relays FSD1 and FSD2. It is intended for non safety-related purposes, and is typically used to signal a programmable logic controller (PLC) when output relay contacts FSD1 and FSD2 open or close.

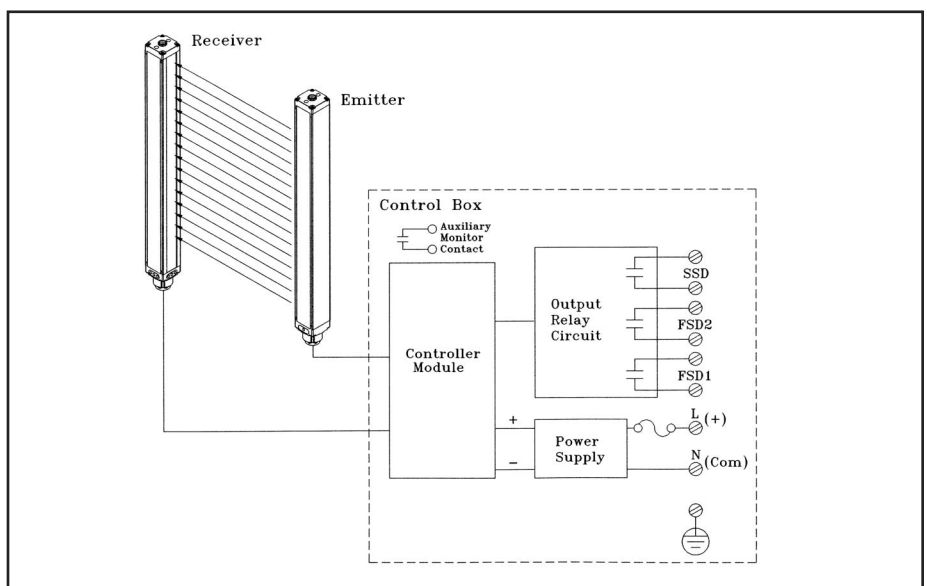

Figure 6. Banner MINI-SCREEN System Functional Schematic

### 2.7 Control Reliability: Redundancy & Self-checking

MINI-SCREEN Systems meet certain U.S. and international *control reliability* standards for safety. Banner MINI-SCREEN Systems must reliably send a "stop" signal to a guarded machine as follows:

- 1) The MINI-SCREEN System must provide a "stop" signal to the guarded machine, within 48, 60, or 72 milliseconds\*, whenever the defined area is interrupted, and
- 2) The MINI-SCREEN System must provide a "stop" signal to the guarded machine when internal component failures have occurred which compromise the integrity of the MINI-SCREEN System itself.

**Regarding the first situation:** In order for the machinery guarded by the MINI-SCREEN System to be stopped as described, *the guarded machine must be capable of stopping at any point in its machine cycle*. This means that the MINI-SCREEN System cannot be used with certain types of machinery, such as single stroke (also known as "full revolution" clutched) machinery, or any machine with inconsistent machine response time and stopping performance. If there is any doubt about whether or not your machinery is compatible, contact the Banner Factory Application Engineers.

**Regarding the second situation:** This type of component failure includes any internal MINI-SCREEN System failure which could prevent or delay the output relays of the MINI-SCREEN System from going to a *trip condition* or a *lockout condition* in response to a situation which, in normal operation, would cause them to do so. The ability of the MINI-SCREEN System to send a "stop" signal even when such a component failure has occurred depends upon the design principle of *redundancy*.

*Redundancy* requires that MINI-SCREEN System circuit components be "backed up" to the extent that, if the failure of any single component will prevent effective stopping action when needed, that component must have a redundant counterpart which will perform the same function.

The microprocessor-controlled MINI-SCREEN System is designed with *diverse redundancy*. Diverse redundant components are of different designs, and microprocessor programs used by them run from different instruction sets written by different programmers.

Redundancy must be maintained for as long as the MINI-SCREEN System is in operation. Since a redundant system is no longer redundant once a component has failed, MINI-SCREEN Systems are designed to be continuously *self-checking*. A component failure detected by or within the self-checking system causes a "stop" signal to be sent to the guarded machine *and* puts the MINI-SCREEN System into a *lockout condition*.

Recovery from this type of lockout condition requires replacement of the failed component (to restore redundancy) and a *key reset*. Possible causes of lockout conditions are listed in Section 2.3. The Diagnostic Indicator LEDs are used to diagnose internal causes of a lockout condition (Section 5.1).

\*Depending upon sensor length: see Specifications, page 52.

## 3. System Installation & Alignment

### 3.1 Appropriate Application



#### CAUTION . . .

In order for the machinery guarded by the MINI-SCREEN System to be stopped as described, *that machinery must be capable of stopping at any point in its machine cycle.* This means that the MINI-SCREEN System cannot be used with certain types of machinery (see listing, at right). **If there is any doubt about whether or not your machinery is compatible with the MINI-SCREEN System, contact Banner's Application Engineers at the factory.**

The MINI-SCREEN System may only be used to guard machinery that is *capable of stopping motion immediately* upon receiving a stop signal and at any point in its machine cycle.

The MINI-SCREEN System may *not* be used with single stroke (also called "full revolution") clutched machinery, as this type of machinery is incapable of stopping immediately.

MINI-SCREEN Systems also may not be used on certain other types of machinery. This includes any machine with inadequate or inconsistent stopping response time, and any machine that ejects materials or component parts through the defined area.

MINI-SCREEN Systems may not be used in any environment that is likely to adversely affect the efficiency of a photoelectric sensing system. For example, corrosive chemicals or fluids or unusually severe levels of smoke or dust, if not controlled, may degrade the efficiency of the MINI-SCREEN System.

MINI-SCREENS *may not* be used as tripping devices to initiate machine motion (PSDI applications) on mechanical power presses, per OSHA regulation 29 CFR 1910.217.



#### WARNING . . .

The Banner MINI-SCREEN System is a point-of-operation machine guarding device. Its ability to perform this function depends upon the appropriateness of the application and upon the MINI-SCREEN System's proper mechanical and electrical installation and interfacing to the machine to be guarded. If all mounting, installation, interfacing, and checkout procedures are not followed properly, the MINI-SCREEN System cannot provide the protection for which it was designed. The user has the responsibility to ensure that all local, state, and national laws, rules, codes, or regulations relating to the installation and use of this control system in any particular application are satisfied. Extreme care should be taken to ensure that all legal requirements have been met and that all technical installation and maintenance instructions contained in this manual are followed. ***Read Section 3 of this manual carefully before installing the system. Failure to follow the instructions in Section 3 (and its subsections) could result in serious bodily injury or death.***

The user has the sole responsibility to ensure that the Banner MINI-SCREEN System is installed and interfaced to the guarded machine by **qualified persons** in accordance with this manual and applicable safety regulations. A "qualified person" is defined as "a person or persons who, by possession of a recognized degree or certificate of professional training, or who, by extensive knowledge, training, and experience, has successfully demonstrated the ability to solve problems relating to the subject matter and work" (ANSI/ASME B30.2-1983).



#### WARNING . . .

##### Use of MINI-SCREEN Systems for Perimeter Guarding

If a MINI-SCREEN System is installed for use as a perimeter guarding system, the Machine Primary Control Elements (MPCEs) of the guarded machine must be wired such that any interruption of the defined area will cause immediate arrest of the dangerous motion of the guarded machine. Following any interruption, the dangerous machine motion must be able to be initiated *only* after actuation of a reset switch. This reset switch must be located outside of the area of dangerous motion, and must be positioned so that the area of dangerous motion may be observed by the switch operator during the reset operation. Failure to observe this warning could result in serious bodily injury or death.

# Installation & Alignment

## 3.2 Mechanical Installation Considerations

The two factors that influence the layout of the MINI-SCREEN System's mechanical installation the most are:

- *separation distance*, and
- *hard guarding*.

### 3.2.1 Separation Distance

The MINI-SCREEN System must be able to react fast enough, when a hand or other object is inserted into the defined area, to send a stop signal to the guarded machine before the object or hand reaches the closest reachable hazard point on the machine. The *separation distance* is the minimum distance that is required between the midpoint of the defined area and the closest reachable hazard point. The actual separation distance required depends upon several factors, including the *speed of the hand (or object)*, the *total system stopping time* (of which there are several response time components), and the *depth penetration factor*. The formula used to calculate the separation distance is:

$$D_s = K \times (T_s + T_r) + D_{pf}$$

where:

- D<sub>s</sub>** = the separation distance;
- K** = the OSHA-recommended hand speed constant of 63 inches per second (NOTE 1, below);
- T<sub>s</sub>** = the overall stop time of the machine measured from the application of the "stop" signal to the final ceasing of all motion (including stop times of all relevant control elements, and measured at maximum machine velocity). See the WARNINGS (right), NOTE 2 (below), and the NOTICE regarding MPCEs (page 29).
- T<sub>r</sub>** = the response time of the MINI-SCREEN System:  
.048 sec. for 4.5 in. to 16 in. emitter/receiver  
.060 sec. for 20 in. to 32 in. emitter/receiver  
.072 sec. for 36 in. to 48 in. emitter/receiver
- D<sub>pf</sub>** = the added distance due to depth penetration factor, as prescribed in OSHA 1910.217 and ANSI B11 standards:  
**D<sub>pf</sub> = 1.6 inches for 30-foot range sensors with floating blanking off**  
**D<sub>pf</sub> = 2.5 inches for 60-foot range sensors with floating blanking off**  
**D<sub>pf</sub> = 5.0 inches for 30-foot range sensors with floating blanking on**  
**D<sub>pf</sub> = 5.9 inches for 60-foot range sensors with floating blanking on**

- 1) The OSHA-recommended hand-speed constant K has been determined by various studies, and although these studies indicate speeds of 63 in/sec to over 100 in/sec, they are not conclusive determinations. The employer should consider all factors, including the physical ability of the operator, when determining the value of K to be used.
- 2) T<sub>s</sub> is usually measured by a stop-time measuring device. If the specified machine stop time is used, we recommend that at least 20% be added as a safety factor to account for clutch/brake system deterioration.
- 3) Use of floating blanking will always cause the required D<sub>s</sub> to increase.



#### WARNING. . .

Banner MINI-SCREEN System emitters and receivers must be

mounted at a distance from moving machine parts that is determined by OSHA standards found in Section 1910.217 (c)(3)(iii)(e). Failure to establish and maintain the required separation distance exactly as described in Section 3.2 of the MINI-SCREEN manual could result in serious bodily injury or death.



#### WARNING . . .

The measurement of stop time (T<sub>s</sub>) must include the response time of *all*

devices or controls that react to stop the machine. If all devices are not included, the calculated safety distance (D<sub>s</sub>) will be too short. This can lead to serious bodily injury or death. *Be sure to include the stop time of all relevant devices and controls in your calculations.*



#### CAUTION . . .

Floating blanking increases D<sub>pf</sub>. (see values at left).

You must increase the penetration factor to calculate the separation distance whenever floating blanking is used.

Always turn floating blanking "off" when the larger minimum object detection size is not required.

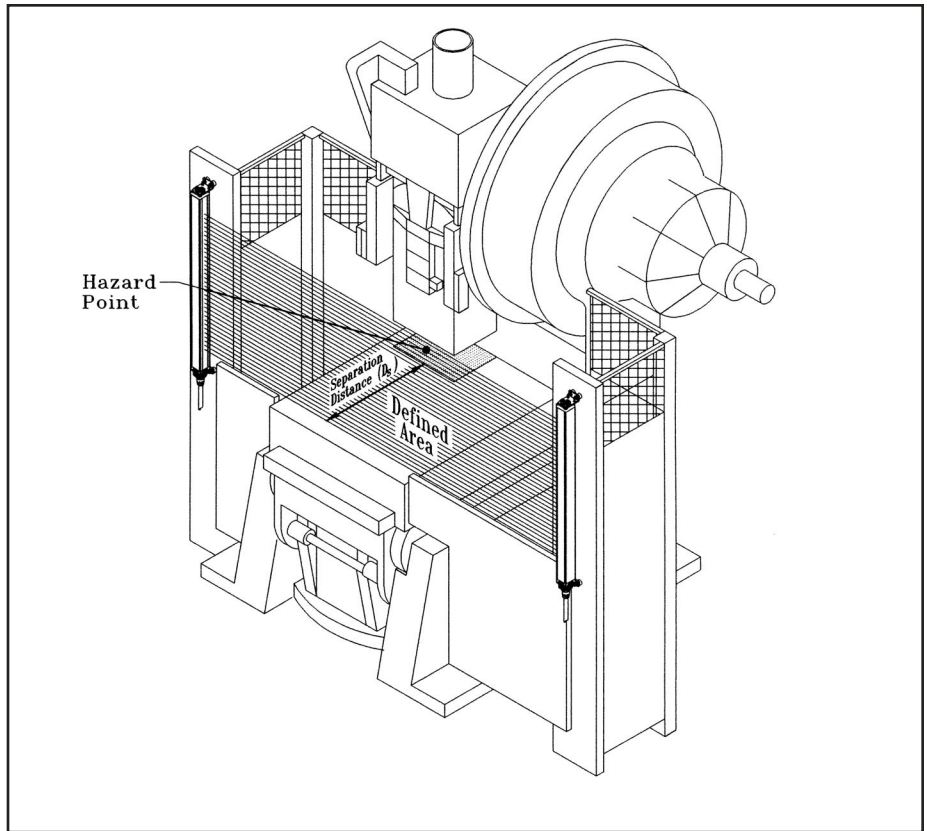

**Figure 7. Separation Distance**

## Example: Separation Distance (Ds) Calculation

The following is an example showing how to use the formula from page 14 to calculate the safety distance ( $D_S$ ). We will use these numbers for the variables in the formula:

Sensors have 9 m (30 ft) range

$K = 63$  inches per second (the hand speed constant set by OSHA)

$T_S = .250$  second (the total stop time of the example machine, specified by machine manufacturer)

$T_R = .048, .060, \text{ or } .072$  second (the specified response time of the MINI-SCREEN System; see Specifications, page 52 or page 14.)

Our example uses floating blanking, so we use a  $D_{pf}$  of 5 inches (page 14). Response time for this example is .060 second. Substitute the numbers into the formula as follows:

$$D_S = K \times (T_S + T_R) + D_{pf}$$

$$D_S = 63 \times (.250 \times 1.2^* + .060) + 5 = 28 \text{ inches}$$

Therefore, in this example, the MINI-SCREEN emitter and receiver must be mounted such that no part of the defined area will be closer than 28 inches to the closest reachable hazard point on the guarded machine.

*\*20% safety factor (see NOTE 2, on page 14)*

### 3.2.2 Hard Guarding

ANSI B11.1-1988, E6.3.2 (14) requires that "all areas of entry to the point of operation not protected by the presence-sensing device shall be otherwise safeguarded". The hazard point must be accessible *only* through the defined area. This means that mechanical barriers (screens, bars, etc.), or supplemental presence sensing devices (*supplemental guarding*) must be installed, wherever needed, to prevent any person from reaching around, under, or over the defined area and into the hazard point, and to prevent any person from standing between the defined area and the hazard point (see OSHA 1910.212). The use of mechanical barriers for this purpose is called "hard guarding" (see the WARNING on the right and the hard guarding example, below).

There must be no gaps between the hard guarding and the edges of the defined area. Also, OSHA specifies a relationship between the distance of the hard guard barrier from the point of operation and the maximum allowable size of openings in that barrier (see OSHA 1910.217, Table O-10). Openings in the hard guard material must meet OSHA criteria.

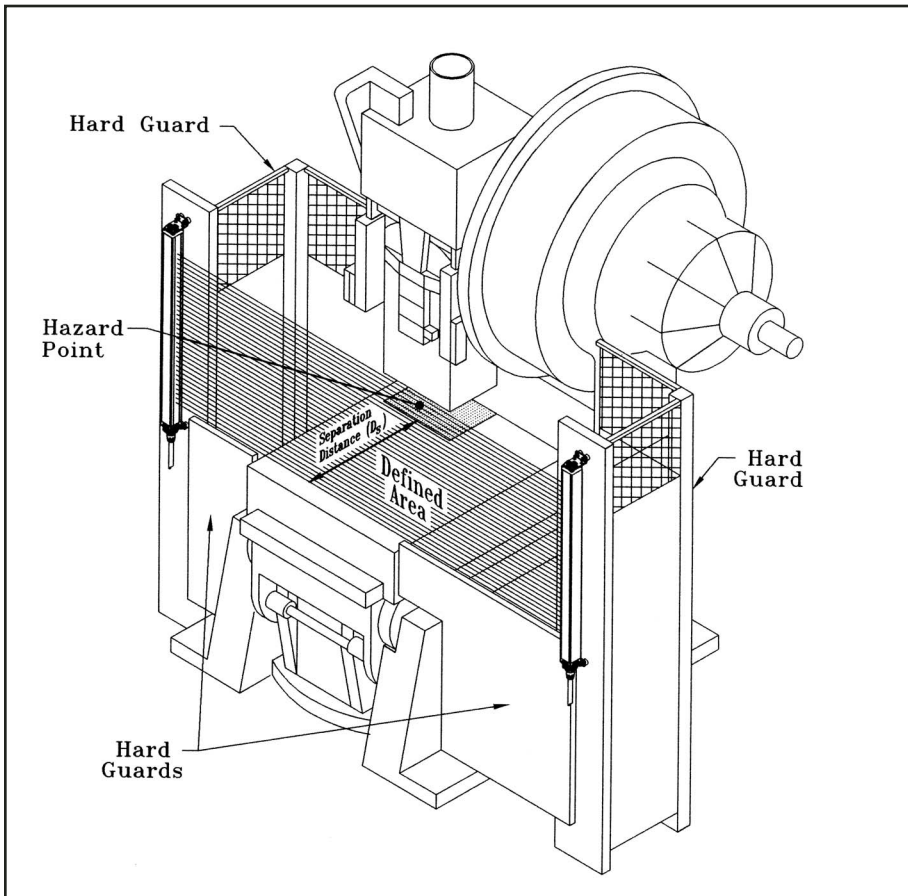

Figure 8. Example of "Hard Guarding"



#### WARNING. . .

The point of operation must be accessible *only* through the defined area. Mechanical barriers (screens, bars, etc.), or supplemental presence sensing devices (*supplemental guarding*) must be installed, wherever needed, to prevent any person from reaching around, under, or over the defined area and into the point of operation, and also to prevent any person from entering the space between the defined area and the point of operation. (See OSHA 1910.212). The use of mechanical barriers for this purpose is called "hard guarding". There must be no gaps between the hard guarding and the edges of the defined area. Openings in the hard guard material must meet OSHA criteria (see OSHA 1910.217, Table O-10).

Supplemental presence sensing devices, such as safety mats, must be used if the space between the defined area and the nearest danger point is large enough to allow a person to stand undetected by the MINI-SCREEN System.



## 3.2.3 Emitter and Receiver Orientation



### WARNING . . .

The emitters and receivers of the MINI-SCREEN System must be installed with their corresponding ends (either cabled ends or non-cabled ends) pointing in the same direction (i.e. both cabled ends "up", both cabled ends "down", etc.). Failure to do this will impair the performance of the MINI-SCREEN System and result in incomplete guarding. See Figure 10a. Failure to observe this warning could result in serious bodily injury or death.

It is absolutely necessary that the emitter and receiver are mounted such that they are perfectly parallel to each other and aligned in a common plane with both cable ends pointing in the same direction. Never mount the emitter with its cable end oriented opposite to the cable end of the receiver. If the emitter and receiver cable ends are oriented opposite to each other, there will be voids in the light curtain through which objects can pass undetected (see Figure 10a).

The emitter and receiver may be oriented in a horizontal plane, or at any angle between horizontal and vertical. However, the cable ends must always point in the same direction. Always be certain that the light screen completely covers all access to the hazard point which is not already protected by hardguarding or another means of supplemental guarding.

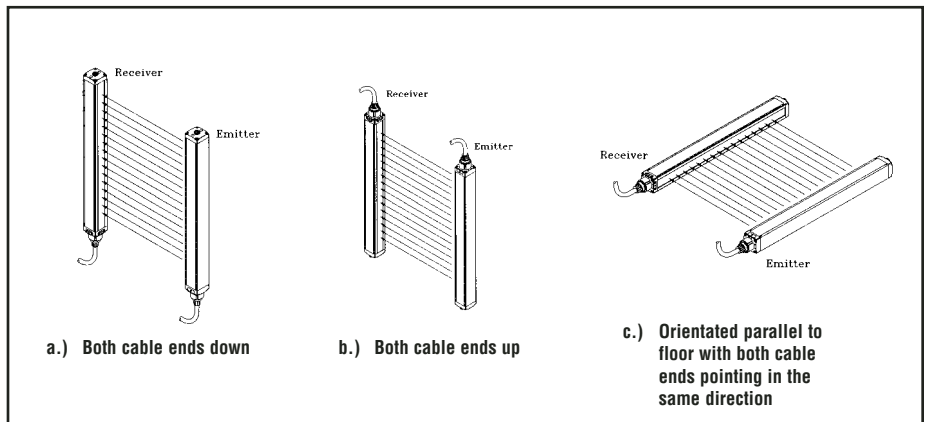

Figure 9. Examples of Correct Emitter and Receiver Orientation

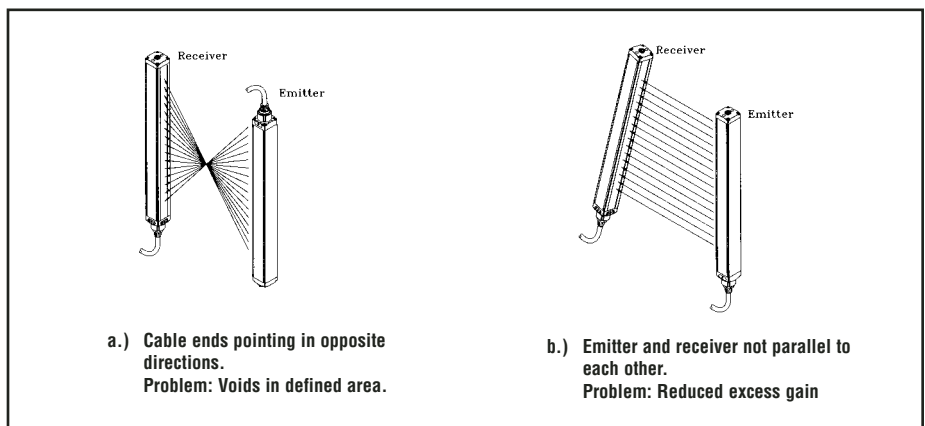

Figure 10. Examples of Incorrect Emitter and Receiver Orientation

### 3.2.4 Adjacent Reflective Surfaces

A reflective surface located adjacent to the defined area may deflect one or more beams of the light curtain around an object which is in the defined area. In the worst case, an object may pass through the defined area undetected.

A reflective surface may be a part of the machine or the workpiece and may include shiny metal or plastic or surfaces with glossy paint. Where possible, reflective surfaces which are adjacent to the defined area should be roughened or covered with a dull material. Where this is not possible (as with a reflective workpiece), the sensor mounting should include a means of restricting the field of view of the receiver or the spread of the light from the emitter (see Figure 8).

Beams deflected by reflective surfaces are discovered during the initial checkout procedure (Section 3.5.3), the final alignment and checkout procedure (Section 6.1), and also by the periodic checkout procedures (Sections 6.2, 6.3, and 6.4).

### 3.2.5 Use of Corner Mirrors

MINI-SCREEN sensors may be used with one or more corner mirrors. The use of corner mirrors somewhat reduces the maximum specified emitter/receiver separation (see page 41). Corner mirrors and stands are available from Banner. Contact the factory Applications Engineering Department for information.

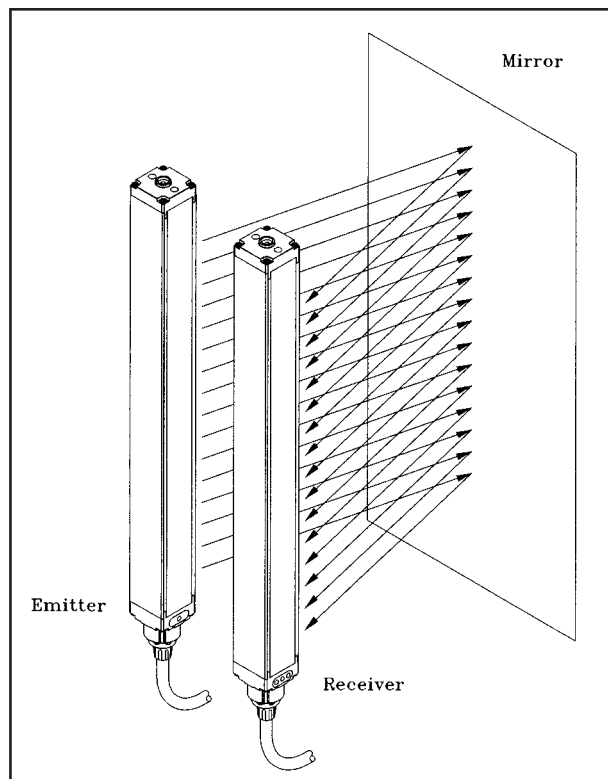

**Figure 11. Never use the MINI-SCREEN Sensors in a retroreflective mode.**



#### **WARNING. . .**

It may be possible for a highly reflective surface (such as a shiny machine surface or a shiny workpiece) to reflect sensing light around an object in the defined area, thus preventing that object from being detected. This potentially dangerous condition is discovered using the "trip test" as described in the Initial Checkout Procedure (Section 3.5.3), the Alignment Procedure (Section 6.1), and the periodic checkout procedures (Sections 6.2, 6.3, and 6.4).

When this condition is discovered, eliminate the problem reflection(s). If possible, relocate the sensors to move the curtain of light beams away from the reflective surface(s). If relocating the sensors, be careful to retain at least the required separation distance (Section 3.2.1). Otherwise, paint, mask, or roughen the interfering shiny surface to reduce its reflectivity. Use the trip test to verify that these changes have eliminated the problem reflection(s).

**NOTE:** If the workpiece is especially reflective and comes close to the curtain, perform the trip test with the shiny workpiece in place.



#### **WARNING. . .**

The MINI-SCREEN System is not designed for use in a retroreflective mode where the sensors are mounted adjacent to each other and the light from the emitter is bounced back directly to the receiver by a mirror or other reflective surface. Never use MINI-SCREEN sensors in a retroreflective mode, as illustrated in Figure 11. Sensing in this mode and could result in serious injury or death.

## 3.2.6 Installation of Multiple MINI-SCREEN Systems

Whenever the emitter and receiver pairs of two or more MINI-SCREEN Systems are adjacent to one another, there is potential for optical crosstalk to take place between systems. To minimize optical crosstalk, it is recommended to alternate emitters and receivers, as shown in Figure 12.

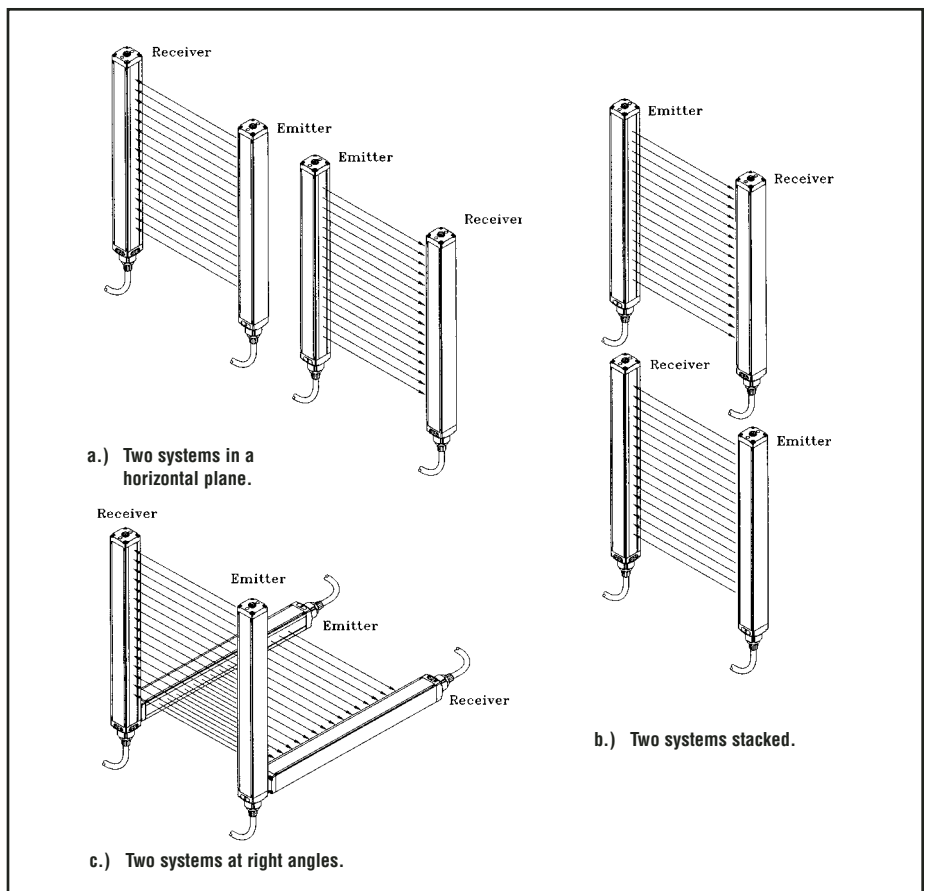

**Figure 12. Installation of Multiple MINI-SCREEN systems. Alternate Emitters and Receivers to Avoid Optical Crosstalk.**

When three or more systems are installed in a horizontal plane, (as shown for two pairs in Figure 12a.), optical crosstalk may occur between those sensor pairs which have their emitter and receiver lenses orientated in the same direction. In this situation, optical crosstalk may be controlled by mounting these sensor pairs exactly in line with each other within the same plane, or by adding a mechanical light barrier between the pairs.

## 3.3 Mounting Procedure

### Sensor Mounting

Banner MINI-SCREEN System emitters and receivers are small, lightweight, and easy to handle during mounting. The mounting brackets (supplied) allow  $\pm 30$  degrees rotation.

From a common point of reference, make measurements to locate the emitter and receiver in the same plane with their midpoints directly opposite each other. **Important: The connector ends of both sensors must point in the same direction (see drawings and WARNING, page 17).** Mount the emitter and receiver brackets using the vibration isolators and M4 Keps nuts (all supplied). See Figure 13. Standard #8-32 bolts may be substituted (and the vibration isolators eliminated) in situations where the emitter and receiver are not subjected to shock or vibration forces. While the internal circuits of the emitter and receiver are able to withstand heavy impulse forces, the vibration isolators dampen impulse forces and prevent possible damage due to resonant vibration of the emitter or receiver assembly.

Mount the emitter and receiver in their brackets and position the red lenses of the two units directly facing each other. Measure from one or more reference planes (e.g. the building floor) to the same point(s) on the emitter and receiver to verify their mechanical alignment. If the units are positioned exactly vertical or horizontal to the floor, a carpenter's level is useful for checking alignment. A straightedge or a string extended between the sensors also helps with positioning. Also check "by eye" for line-of-sight alignment. Make any necessary final mechanical adjustments, and hand-tighten the bracket hardware. A detailed alignment procedure is given in Section 6.1.

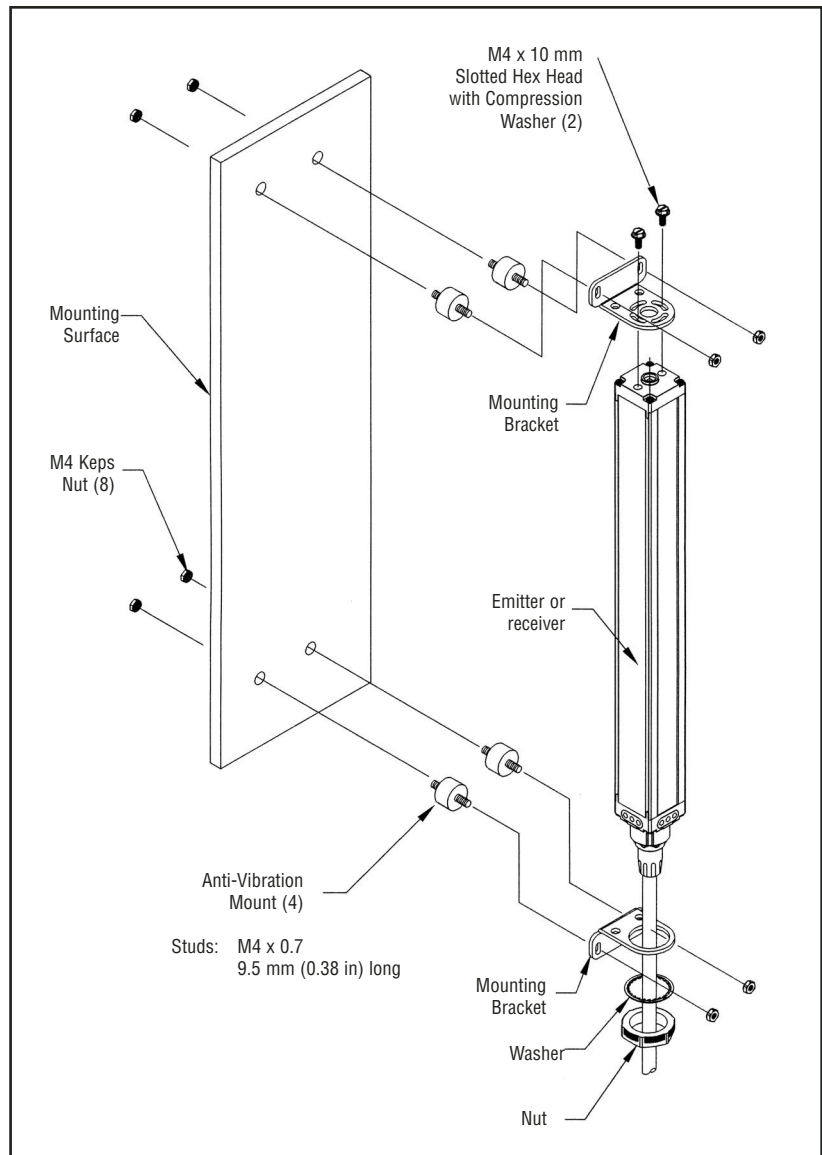

Figure 13. Emitter and Receiver Mounting Hardware

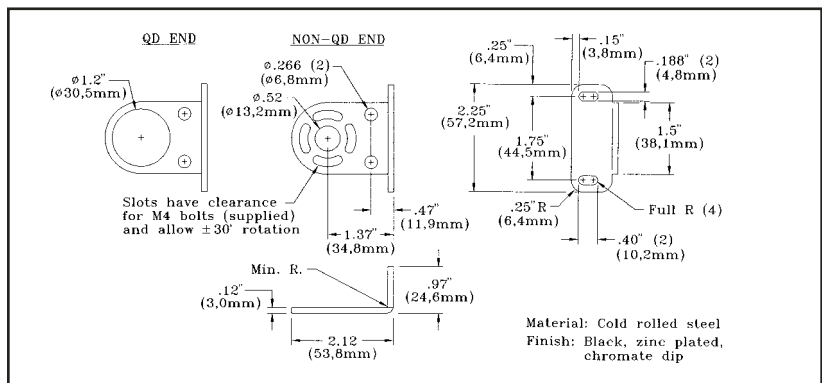

Figure 14. Emitter and Receiver Mounting Bracket Dimensions.

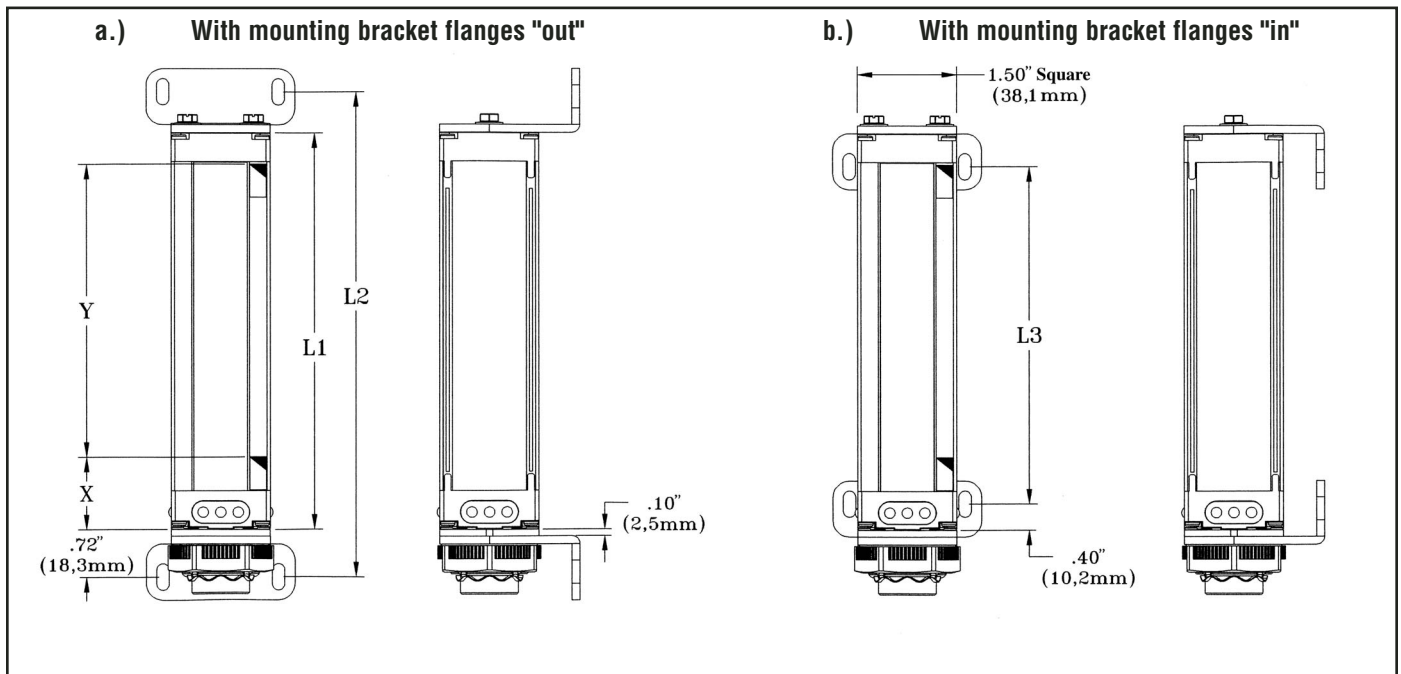

Figure 15. Emitter and Receiver Mounting Dimensions and Location of Defined Area.

Models	Housing Length		Distance Between Bracket Holes				Defined Area			
	L1		L2		L3		X		Y	
	(inch)	(mm)	(inch)	(mm)	(inch)	(mm)	(inch)	(mm)	(inch)	(mm)
MSE424 emitter MSR424 receiver	6.0	153	7.4	188	5.1	130	1.1	28	4.5	114
MSE824 emitter MSR824 receiver	10.0	254	11.3	287	9.1	231	1.1	28	8.5	215
MSE1224 emitter MSR1224 receiver	14.0	356	15.3	389	13.1	333	1.2	30	12	305
MSE1624 emitter MSR1624 receiver	18.0	457	19.3	490	17.1	434	1.2	30	16	406
MSE2024 emitter MSR2024 receiver	22.0	558	23.3	592	21.1	536	1.2	30	20	508
MSE2424 emitter MSR2424 receiver	26.0	659	27.3	693	25.1	637	1.2	30	24	610
MSE2824 emitter MSR2824 receiver	30.0	761	31.3	795	29.1	739	1.3	33	28	711
MSE3224 emitter MSR3224 receiver	33.9	862	35.3	896	33.0	838	1.3	33	32	813
MSE3624 emitter MSR3624 receiver	37.9	963	39.3	998	37.0	940	1.3	33	36	914
MSE4024 emitter MSR4024 receiver	41.9	1064	43.3	1100	41.0	1041	1.3	33	40	1016
MSE4424 emitter MSR4424 receiver	45.9	1166	47.3	1201	45.0	1143	1.3	33	44	1118
MSE4824 emitter MSR4824 receiver	49.9	1267	51.2	1300	49.0	1245	1.3	33	48	1219

## Installation & Alignment

Connect the shielded cables to the emitter and receiver and route them (per local wiring code for low-voltage dc control cables) to the control box mounting location. (NOTE: Emitter and receiver cables must be routed to the control box knockouts closest to terminal barrier TB3; see Figures 19 and 20.) The same cable type is used for both emitter and receiver (two cables required per system). Cables may be cut to length at the time of installation. Emitter and receiver cable lengths may not exceed 50 feet (each). Do not trim the cables until you are certain that you have routed all cables properly (see Figures 19 and 20). The cable braid at the control box connection points may be either removed or twisted together with the drain wire for attachment to the wiring block.

### Control Box Mounting

Mount the MINI-SCREEN System control box in a convenient location that is free from heavy impulse force and high-amplitude vibration. **The control box *must* be mounted at a location which provides an unobstructed view of the defined area.** Mounting hole information is given in Figure 17 (below). The MINI-SCREEN Controller module must be configured *before* initial checkout and use. Controller configuration is done at the row of DIP switches along the edge of the controller module (Figure 18). The controller will automatically sense the length of the emitter and receiver, and set its response time accordingly.

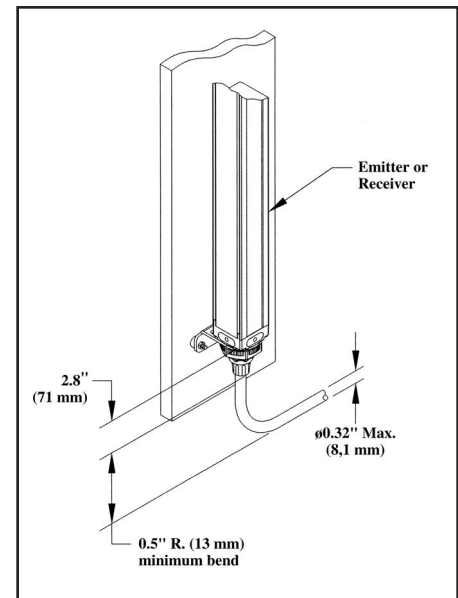

Figure 16. Quick Disconnect Cable Clearance Dimensions.

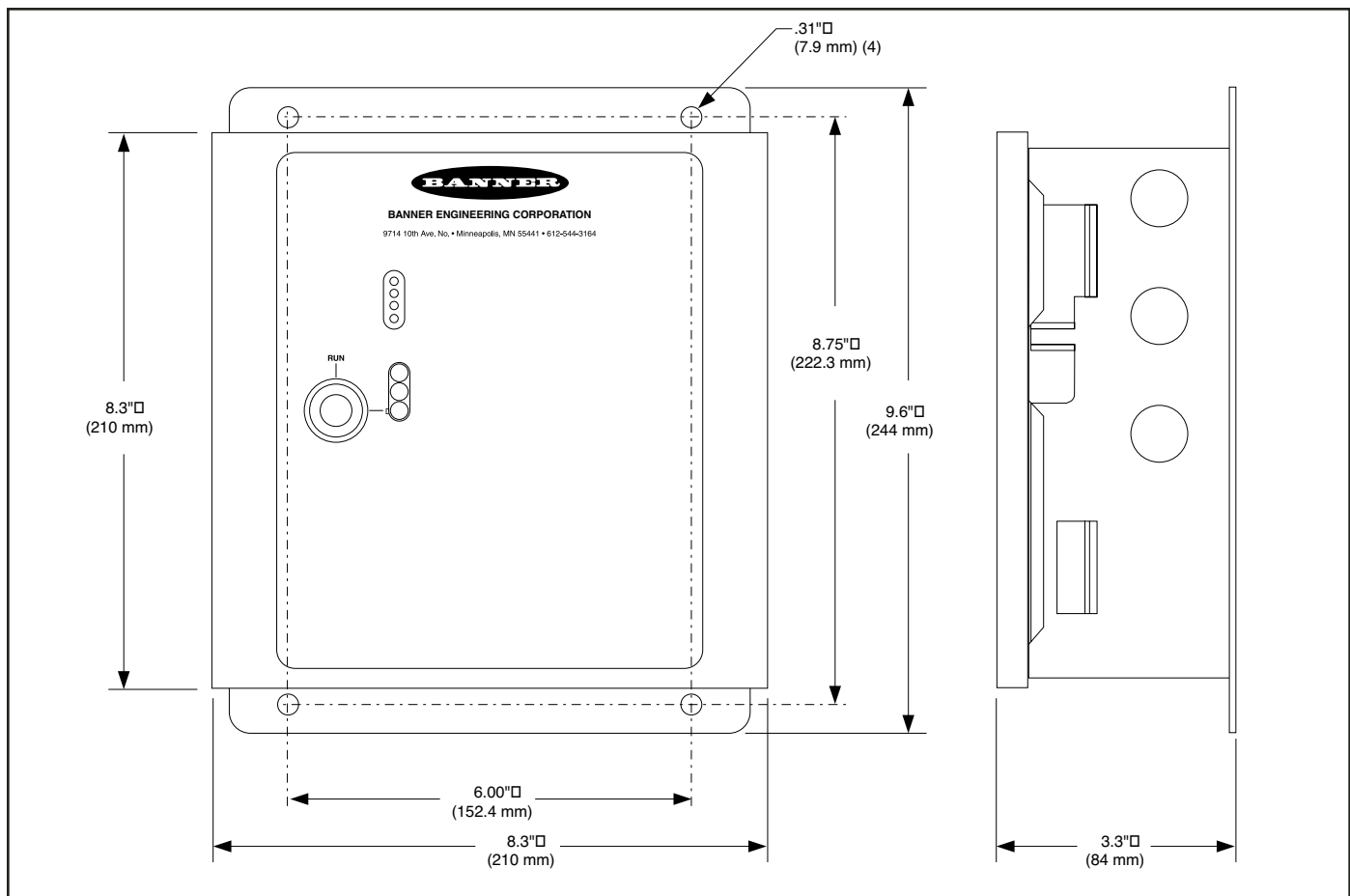
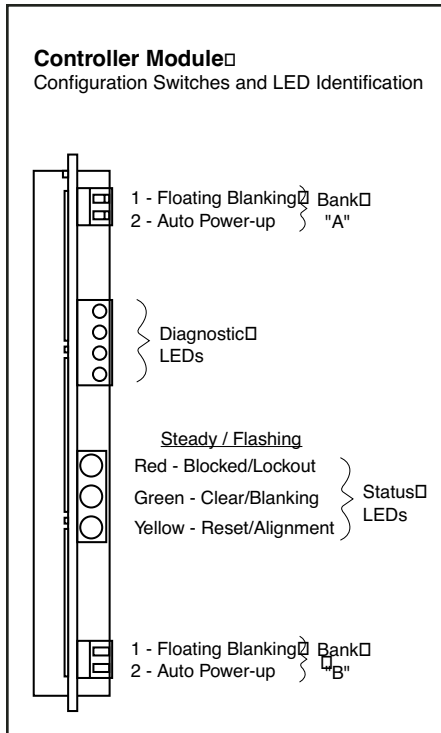

Figure 17. Control Box Mounting Hole Locations.

## 3.4 Controller Module Configuration



**Figure 18. Controller Configuration Switches**

The parameters to be manually configured are:

- Floating blanking "on" or "off".
- Auto Power-up "on" or "off".

NOTE: The factory setting for both parameters is "off".

Because it has redundant microprocessors, the controller module has two identical DIP switch banks (bank A and bank B) which must be set identically. Failure to set both banks identically will cause a lockout condition when power is applied to the control box. **Power to the MINI-SCREEN System must always be "off" when changing switch settings.** Changing switch settings with power "on" will cause a lockout condition. A switch pushed to the left is "on"; a switch pushed to the right is "off". Set the configuration switches as follows:

### Floating Blanking ON or OFF

Locate the floating blanking (FB) configuration switch in bank A (switch #1). Set the switches identically at banks A and B. Be aware of the difference in minimum object sensitivity, penetration factor, and required light screen separation distance between the "on" and "off" settings (refer to Sections 2.1 and 3.2.1).

### Maximum Object Ignore Size Using Floating Blanking

9 m (30 ft) range sensors: 20.3 mm (0.80 in)

18 m (60 ft) range sensors: 16.5 mm (0.65 in)

**Note:** Assumes that the object encounters the light screen perpendicular to the plane of light.

### Auto Power-up feature ON or OFF

Locate the Auto Power-up (AP) configuration switch (switch #2) in bank A. If Auto Power-up is "on" (switches pushed to the left) when power is applied to the MINI-SCREEN System, the controller will automatically reset after conducting and passing an internal system checkout. If the switch is "off" (pushed to the right), this initial reset is manual (via the key reset switch on the front panel). Regardless of the setting of this switch, a *key reset* is always necessary to recover from an internal *lockout condition*. To select Auto Power-up, remove the protective coating on switch #2 and push the switch to the left ("on") position. The switches must be set identically at banks A and B.

## 3.5 Electrical Hookup and Checkouts

Make the electrical connections in the order that they are presented in Sections 3.5.1 through 3.5.7. **Exercise care when removing control box knockouts, so as to not damage the contents of the control box.**

The following wiring connections are located inside the control box:

- Emitter and receiver cables,
- System power,
- Output relay connections (FSD1, FSD2, and SSD),
- Auxiliary Monitor Relay, and
- Remote devices (key switch and test input).

Several conduit knockouts are provided around the sides of the control box. As you complete the wiring in the following sections, select knockout locations that are closest to the internal control box connection points that you want to access. Refer to Figures 19 and 20. **NOTE:** Except for emitter and receiver cable entries (for which cable glands are supplied), it is the user's responsibility to maintain NEMA 13 sealing at all cable entries into the control box.

Note that the wiring barriers inside the control box can accept conductors no larger than #14 AWG. Also, the wires used should have an insulation temperature rating of at least 90°C (194°F).



### WARNING . . .

Electrical hookup must be made by a qualified electrician, and must comply with NEC (National Electrical Code) and local standards. Also, make no more connections to the MINI-SCREEN System than are described in Sections 3.5.1 through 3.5.7. Connection of other wiring or equipment to the MINI-SCREEN System could result in serious bodily injury or death.

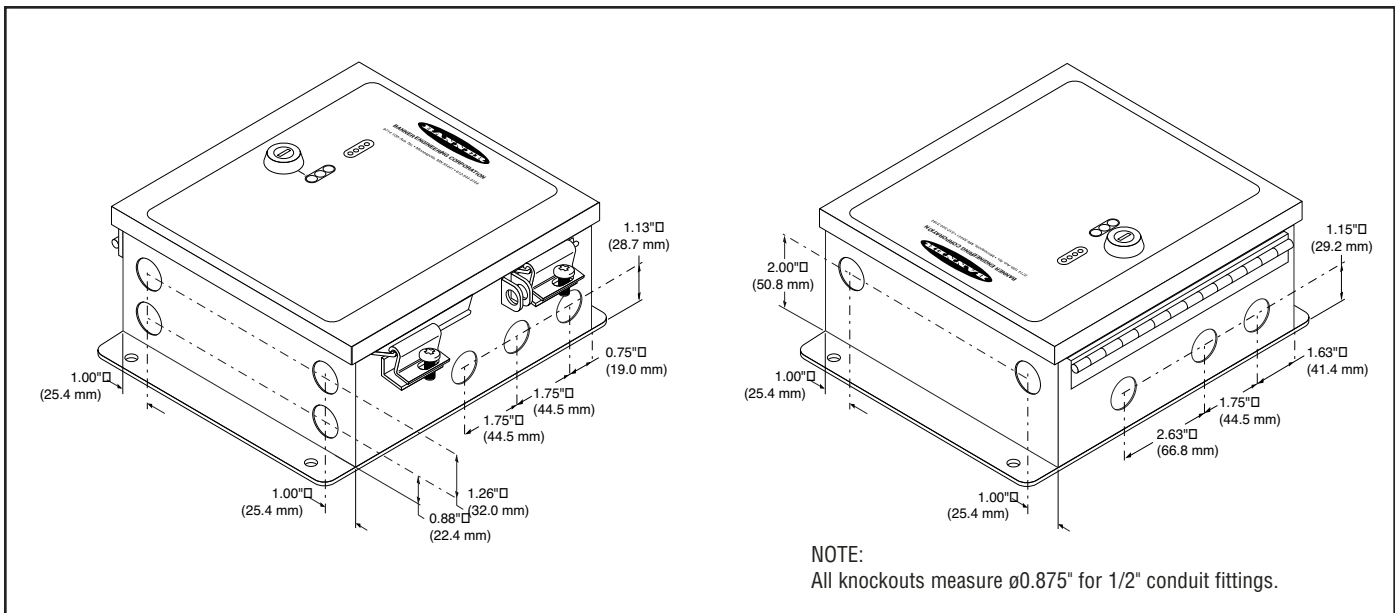

**Figure 19. MINI-SCREEN Control Box Knockout Locations.**



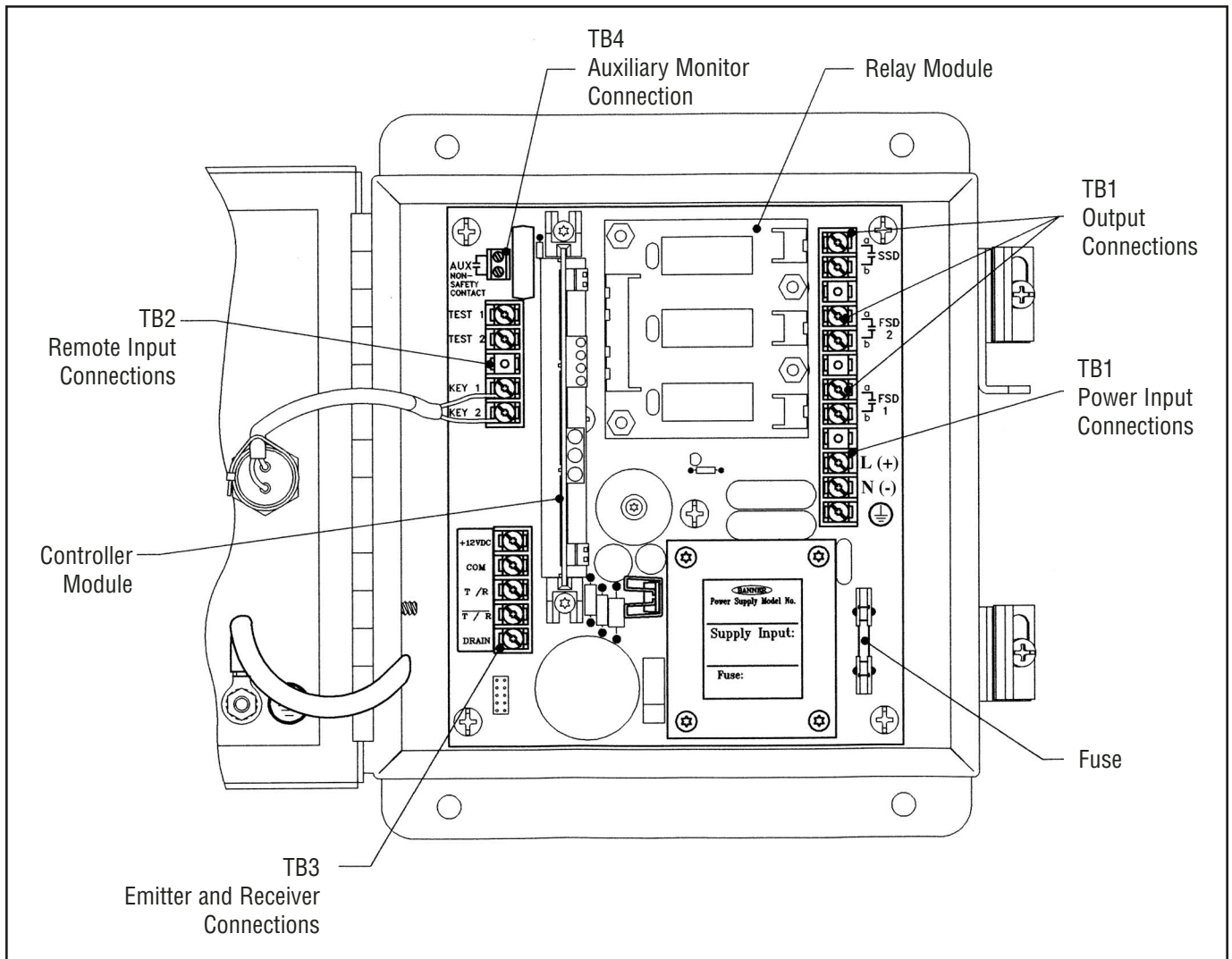
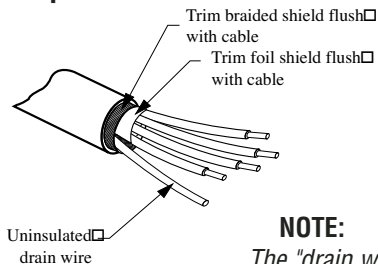

Figure 20. MINI-SCREEN System Electrical Connections

## Emitter and Receiver Cable Preparation



**NOTE:**

The "drain wire" is the uninsulated stranded wire which runs between the braided shield and the foil shield. The foil shield should be removed at the point where the wires exit the cable. The braided shield may be either removed or twisted together with the drain wire for connection to wiring barrier TB3.

## 3.5.1 Emitter and Receiver Hookup

The emitter and receiver cables require two control box knockouts. Two cable gland strain relief fittings are supplied with each control box for the entrance of emitter and receiver cables into the control box. Emitter and receiver cables both connect to wiring barrier TB3 (Figure 20, above). Route the cables through the knockouts nearest to barrier TB3. *Only the use of Banner QDC Series cables (see page 54) can ensure reliable communication of data between the controller and the sensors.* Match the color-coded terminals of wiring barrier TB3 to colors of the wires in each 5-conductor cable. **Double-check your wiring. Incorrect wiring can lead to component damage.** There are no user adjustments or connections inside the MINI-SCREEN sensors themselves.

## 3.5.2 System Power (temporary connection)

As shown in Figure 23 (page 30), the ac lines to the control box connect through the MPCE monitor contacts of the guarded machine. However, do not wire to the MPCEs at this time. Instead, *temporarily* connect power directly at the **L** and **N** terminals of control box wiring barrier TB1. Connect earth ground at the terminal provided. This will allow the MINI-SCREEN System to be checked out, by itself, before permanent power connections through the guarded machine's monitor contacts are made. *Permanent* power connection will be made after MINI-SCREEN System initial checkout, and is covered in Section 3.5.5.

## 3.5.3 MINI-SCREEN System Initial Checkout

This initial checkout procedure must be performed by a *qualified person* (see WARNING, page 13). It must be done **after** connecting the emitter and receiver (Section 3.5.1) and temporary power (Section 3.5.2) to the MINI-SCREEN control box, but **before** the MINI-SCREEN System is connected to the machine to be controlled.

This initial checkout procedure is done when the MINI-SCREEN System is first installed, and must also be performed by a **qualified person** whenever any maintenance or modification is performed on the MINI-SCREEN System or on the machinery guarded by the MINI-SCREEN System. A schedule of required checkouts is given in Section 4.2.



**CAUTION. . .**  
Electrical shock hazard exists when the MINI-SCREEN System has power applied to it and the control box door is open. **Close the hinged control box cover and secure the latches before running this checkout procedure.**

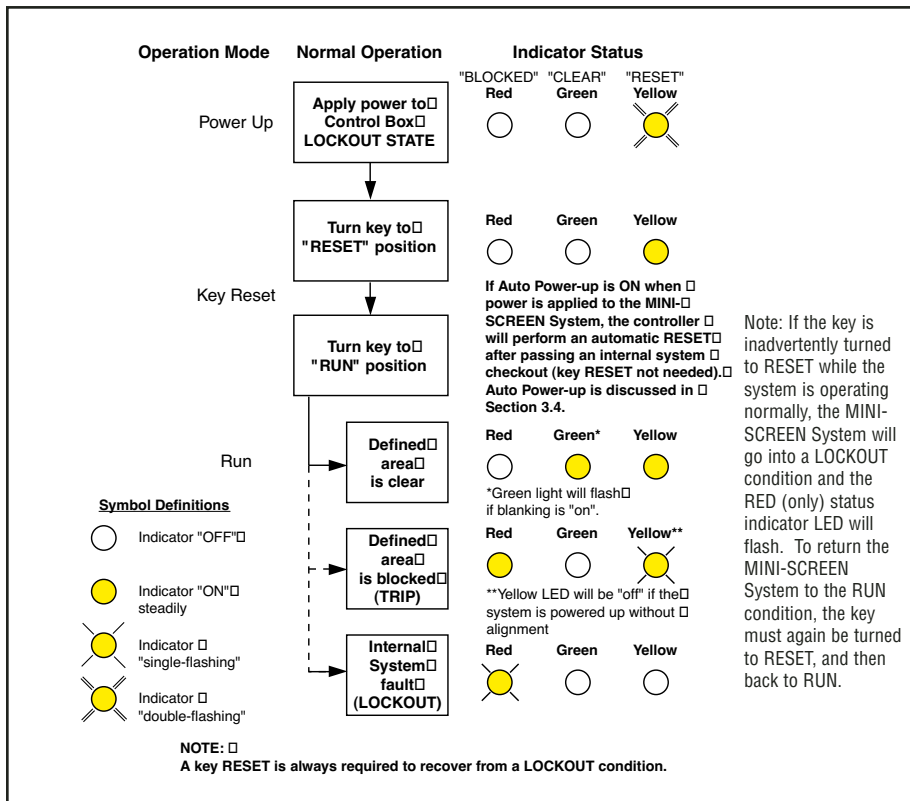

Figure 21. Operating Status LED Conditions

### INITIAL CHECKOUT PROCEDURE:

The MINI-SCREEN System has three operating modes: POWER UP, KEY RESET, and RUN. Monitor the three status LEDs (red, yellow, and green, on the control box front panel or the receiver) and refer to Figure 21.

- 1) **Enter the POWER UP mode** by applying power to the control box (see CAUTION, page 26). With Auto Power-up "off" the System will "power up" in a lockout condition (yellow LED *only* will double-flash). With Auto Power-up "on", the System will automatically enter the RUN mode (step 3).
- 2) **Enter the key RESET mode** by turning the key to the RESET position. The yellow panel LED will glow steadily.

NOTE: Hold the switch in the RESET position for at least one-half second. This allows time for the microprocessors to run a startup diagnostic check routine.

- 3) **Enter the RUN mode** by turning the key from the RESET position to the RUN position.

If the red LED (only) lights and flashes when the system is placed in the RUN mode, an *internal lockout condition* exists. Refer to Section 5.1 to determine the cause of the lockout.

If the red and yellow LEDs come "on", the defined area is not clear (one or more light beams are obstructed) or the system may be out of alignment. This is a *trip condition*. If this occurs, check the defined area for obstruction(s). The red LED will be "on" steadily. The yellow LED will be flashing to indicate the relative number of *made (cleared)* light beams; the faster the flash rate, the more beams are "made".

If the MINI-SCREEN System is properly aligned and the blanking is properly set and all obstructing objects are removed from the defined area, the green and yellow LEDs should come "on" after step #3 has been performed (the green LED will *flash* if blanking is "on", but the yellow LED should be "on" steadily). **If you are setting up the MINI-SCREEN System for the first time, or if the green and yellow LEDs do not come "on" in step #3, perform the alignment procedure in Section 6.1.** When you are certain that the emitter and receiver are aligned properly, tighten the emitter and receiver mounting hardware in position and repeat steps #1-3, above.

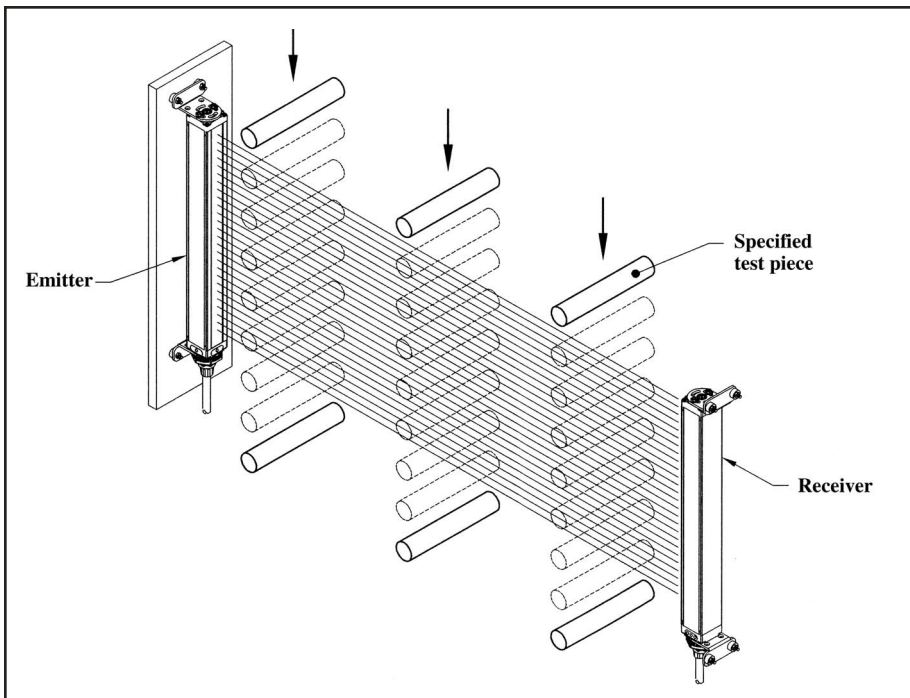

Figure 22. MINI-SCREEN System Trip Test

- 4) **Next, "trip test" the MINI-SCREEN** for object detection capability using the specified test pieces supplied with the control box. To perform the trip test, the key switch must be in the RUN position, the yellow LED must be "on" steadily, and the green LED must either be on steadily (to indicate blanking "off") or flashing (to indicate blanking "on").
- If floating blanking is "off" (green LED "on" steadily)**, use the 0.75" diameter test piece, model STP-2, in step c, if using 9 m (30 ft) range sensors, or the 1.00" diameter test piece, model STP-7, if using 18 m (60 ft) range sensors.
  - If floating blanking is "on" (green LED flashing)**, use the 1.75" diameter test piece, model STP-3, in step c, if using 9 m (30 ft) range sensors, or the 2.00" diameter test piece, model STP-8, if using 18 m (60 ft) range sensors.
  - Pass the specified test piece, very slowly, down the length of the defined area in three paths: close to the emitter unit, close to the receiver unit, and midway between the emitter and receiver units. In each case, the red indicator must come "on" and the green indicator must go "off" and remain "off" for as long as the test piece is within the defined area. If the green indicator comes "on" at any time when the test piece is within the defined area, check for reflective surfaces, and do not continue until the cause is discovered and the situation is resolved.

If the MINI-SCREEN System passes all of the checks in Section 3.5.3, go on to Section 3.5.4. If the MINI-SCREEN System fails any of these checks, *do not attempt to use it until the reason for the failure(s) is identified and the failures are corrected.*



## CAUTION. . .

Electrical shock hazard exists when the MINI-SCREEN System has power applied to it and the control box door is open.

Use extreme caution to avoid electrical shock at all times when the control box door is open. **Always disconnect all power from the MINI-SCREEN System and the guarded machine before making any connections or replacing any component.**



## WARNING. . .

The output relays of the MINI-SCREEN System must be the *final switching devices* for the machinery being guarded. **Never wire an intermediate device (for example, a programmable logic controller -PLC), other than a safety relay, between either FSD and the machine control element switches** (Reference ANSI B11.1-1988, Appendix B4). To do so could result in serious bodily injury or death.

**Connection of the output relays to the guarded machine must be direct and must produce immediate stopping action.**

## NOTICE regarding MPCEs

Each of the two Machine Primary Control Elements (MPCE 1 and MPCE 2) must be capable of immediately stopping the dangerous machine motion, irrespective of the state of the other. These two channels of machine control need not be identical, but the stop time performance of the machine ( $T_s$ , used to calculate the separation distance) must take into account the *slower* of the two channels.

Some machines offer only one primary control element. For such machines, it is necessary to duplicate the circuit of the single MPCE to add a second machine primary control element. Refer to Figure 23 (page 30) or consult the machine manufacturer for additional information.

## 3.5.4 Output Relay Connections

Output relay connections are made at the **FSD1** (Final Switching Device 1), **FSD2** (Final Switching Device 2), and **SSD** (Secondary Switching Device) terminals on wiring barrier TB1. These relays are energized (contacts closed) in normal operation with no obstructions in the defined area. **All** relays become de-energized (their contacts open) in a lockout condition. Relays **FSD1** and **FSD2** (only) de-energize in a trip condition. Before continuing, read **NOTICE regarding MPCEs**, below, left.

**The FSD1 output relay** connects to Machine Primary Control Element #1 (MPCE 1) on the guarded machine. MPCE 1 is an electrically powered element of the guarded machine that directly controls the normal operating motion of the machine in such a way that it is last (in time) to operate when motion is either initiated or arrested. The output contact of relay FSD1 must be connected, as shown in Figure 23, to control power to Machine Primary Control Element #1. The switching capacity of relay FSD1 is 250V ac max., 4 amps max. (resistive load).

**The FSD2 output relay** connects to Machine Primary Control Element #2 (MPCE 2) on the guarded machine. MPCE 2 is an electrically powered element of the guarded machine (in a different control path than MPCE 1) that directly controls the normal operating motion of the guarded machine in such a way that it is last (in time) to operate when machine motion is either initiated or arrested. The output contact of relay FSD2 must be connected, as shown in Figure 23, to control power to Machine Primary Control Element #2. The switching capacity of relay FSD2 is 250V ac max., 4 amps max. (resistive load).

Many different types of mechanisms are used to arrest dangerous machine motion. Examples include mechanical braking systems, clutch mechanisms, and combinations of brakes and clutches. Additionally, control of the arresting scheme may be hydraulic or pneumatic.

As a result, MPCEs may be of several control types, including a wide variety of contactors and electromechanical valves. If your machine documentation leaves any doubt about the proper connection points for the MINI-SCREEN System output relay contacts, *do not make any connections*. Contact the machine builder for clarification regarding connections to the MPCEs and MSCE.

**The SSD output relay** connects to the Machine Secondary Control Element (MSCE) on the guarded machine. The MSCE is an electrically powered element of the guarded machine (independent of the MPCEs) that is capable of removing power from the prime mover of the dangerous part of the machine in the event of an emergency. The output contacts of the SSD relay must be connected, as shown in Figure 23, to the Machine Secondary Control Element such that, if a lockout condition occurs, the motive power will be removed from the machine. The switching capacity of the SSD relay is 250V ac max., 4 amps max. (resistive load).

## Installation & Alignment

Figure 23 (below) shows output relay connections in a generic interfacing situation. The connections between the MINI-SCREEN System outputs and the machine primary and secondary control elements must be direct, and arranged so that any single line fault or earth fault will not result in a circuit failure to a potentially dangerous state.

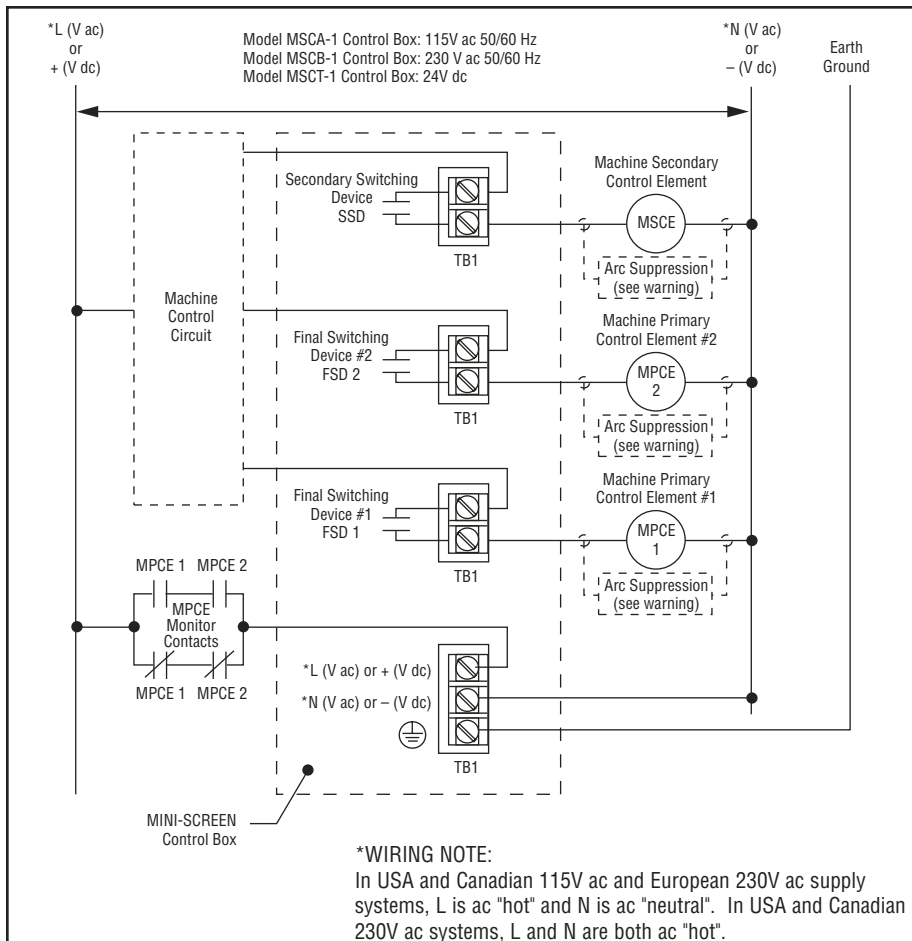

### WARNING. . . Use of MINI-SCREEN Systems for Perimeter Guarding

If a MINI-SCREEN System is installed for use as a perimeter guarding system, the Machine Primary Control Elements (MPCEs) of the guarded machine must be wired such that any interruption of the defined area will cause immediate arrest of the dangerous motion of the guarded machine. Following any interruption, the dangerous machine motion must be able to be initiated *only* by actuation of a reset switch. This reset switch must be located outside of the area of dangerous motion, and must be positioned so that the area of dangerous motion may be observed by the switch operator during the reset operation. Failure to observe this warning could result in serious bodily injury or death.



### WARNING. . .

If arc suppressors are used, they **MUST BE INSTALLED AS SHOWN ACROSS THE COILS OF THE MACHINE CONTROL ELEMENTS. NEVER INSTALL SUPPRESSORS DIRECTLY ACROSS THE CONTACTS OF THE MINI-SCREEN SWITCHING DEVICES!** It is possible for suppressors to fail as a short circuit. If installed directly across the contacts of a MINI-SCREEN switching device, a short-circuited suppressor will create an unsafe condition.



### WARNING

**All** MINI-SCREEN System output contacts (FSD1, FSD2, and SSD) must be used. The generalized wiring configuration, shown here, is provided only to illustrate the importance of proper installation. The actual details of wiring of the MINI-SCREEN system to any particular machine is solely the responsibility of the installer and end user.

Figure 23. Generic Machine Interface, MINI-SCREEN System

## NOTICE regarding MPCE Monitoring Hookup

It is strongly recommended that one normally open and one normally closed auxiliary contact of each MPCE be wired (as shown in Figure 23, page 30) as MPCE monitor contacts. If this is done, any inconsistency of action between the two MPCEs will remove power from the MINI-SCREEN System, causing a lockout condition. ***The use of MPCE auxiliary contacts as MPCE monitor contacts is necessary in order to maintain redundancy.*** MPCE auxiliary contacts used for this purpose must be rated at 55 VA minimum.

**In order to maintain redundancy, the MPCE monitor contacts must be wired as described in section 3.5.5 and Figure 23, page 30.**

### 3.5.5 System Power (permanent connection)

After the initial checkout of Section 3.5.3 has been successfully completed, the power lines to the MINI-SCREEN System must be re-routed to their permanent hookup through the MPCE monitor contacts of the guarded machine. This is important: it ensures that any inconsistency in action between the two MPCEs will remove power from the system. (This is discussed in the **NOTICE regarding MPCE Monitoring Hookup**, left).

Connection of system power is at the **L** and **N** (or + and -) terminals of control box wiring barrier TB1. The MINI-SCREEN System requires 115V ac, 50/60Hz when using control box MSCA-1, 230V ac when using model MSCB-1, or 24V dc when using model MSCT-1. Three-wire connection (ac "hot", ac "neutral", and earth ground) to ac power mains must be done according to NEC and local wiring codes. *Do not operate the MINI-SCREEN System without an earth ground connection.*

After power has been connected to the MINI-SCREEN System and the output relay contacts have been connected to the machine to be controlled, the operation of the MINI-SCREEN System with the guarded machine must be verified before the combined system may be put into service. To do this, **a qualified person must perform the Commissioning Checkout Procedure given in Section 6.2 on page 42.**

### 3.5.6 Auxiliary Monitor Relay

The action of the Auxiliary Monitor Relay contact "follows" the action of output relays FSD1 and FSD2. The Auxiliary Monitor Relay contact is a light-duty contact used for *control functions that are not safety-related*. A typical use is to communicate with a programmable logic controller (PLC). The switching capacity of the Auxiliary Monitor Relay is 125V ac or dc max., 500mA max. Connection to the Auxiliary Monitor Relay contact is made at wiring barrier TB4.

### 3.5.7 Accessory Connections at Terminal Strip TB2

Terminal Barrier TB2 at the upper left corner of the control box allows connection of remote inputs including the following:

*Optional (see page 55) MGA-KSO-1 Remote Key Switch* connects across the **KEY 1** and **KEY 2** terminals of TB2. It is functionally equivalent to the control box key switch. ***The MGA-KSO-1 must be positioned at a location that provides the switch operator with an unobstructed view of the entire defined area.*** We recommend use of shielded cable or separate wiring in a grounded conduit. See Section 5.2.

*Remote Test Input* connects to the **TEST 1** and **TEST 2** terminals of TB2 (see Figure 20, page 25). When connected together (shorted) for a minimum of 50 milliseconds, these terminals provide the MINI-SCREEN System with the equivalent of a **BLOCKED** beam condition, for testing purposes. The switch or switching device used to short the **TEST** contacts must be capable of switching 15 to 50V dc at 20 to 100 mA dc.

### 4. Operating Instructions

#### 4.1 Security Protocol

The MINI-SCREEN control box has a **lockable cover** and a **key-operated front-panel RESET switch**.

In order to prevent access by unauthorized personnel, and to ensure that all lockout conditions come to the attention of a person qualified to deal with them, a lock must be inserted in the lockable cover and the key (or combination) to this lock must be kept in the possession of a *qualified person* as defined in ANSI/ASME B30.2-1983 (see *Glossary* Section). **Qualified persons only should have access to the interior of the MINI-SCREEN System control box.**

The key to the **front-panel RESET switch** should be available to a **designated person** or persons. A designated person is one who is identified and designated in writing, by the employer, as being appropriately trained and qualified to perform a specified checkout procedure. If the machine operator meets these requirements, he/she may be a designated person.

#### 4.2 Periodic Checkout Requirements

In addition to the checkouts that are performed by a qualified person or persons at the time that the MINI-SCREEN System is installed and put into service, **the functioning of the MINI-SCREEN System and the guarded machine must be verified on a regular periodic basis to ensure proper operation. This is absolutely vital and necessary. Failure to ensure proper operation can lead to serious injury or death.**

Checkouts must be performed as follows:

- 1) By a designated person at every power-up of the MINI-SCREEN System (use checkout procedure 6.3, page 44),
- 2) By a qualified person following the correction of every lockout condition (use checkout procedure 6.3, page 44),
- 3) By a designated person at every shift change or machine setup change (use checkout procedure 6.3, page 44),
- 4) By a qualified person semi-annually (every 6 months) following installation of the MINI-SCREEN System (use checkout procedure 6.4, page 45).



#### **WARNING. . .**

The Banner MINI-SCREEN System can do the job for which it was designed only if it and the guarded machine are operating properly, both separately and together. **It is your responsibility to verify this, on a regular basis, as instructed in Section 4.2 and Section 6.**

If the MINI-SCREEN System and the guarded machine do not perform *exactly* as outlined in the checkout procedures, the cause of the problem must be found and corrected before the system is put back into service. Failure to correct such problems can result in serious bodily injury or death.



### 4.3 Normal Operation

#### Power-up

If the Auto Power-up feature is "on" when ac power is applied to the System, the controller performs a system checkout and resets itself, without the need for a key reset. If the Auto Power-up feature is "off" when ac power is applied to the MINI-SCREEN System, it is normal for it to "power up" into a lockout condition. To prepare the MINI-SCREEN System for operation after a "power-up" lockout, the designated person must perform a key reset:

- a) Turn the key to the RESET position (yellow LED goes "on" steadily).

Wait at least one-half second, then

- b) Turn the key to the RUN position.

*If the defined area is clear, the green\* and yellow LEDs will go "on" (red LED goes "off").*

*If the emitter and receiver are misaligned, the red LED will come "on". The yellow LED will single-flash at a rate that indicates the relative number of light beams established.*

*If the defined area is blocked and the emitter and receiver are in alignment, the red LED will come "on", and the yellow LED will single-flash at a rate that indicates the relative number of light beams established.*

The green and yellow LEDs should be "on" steadily\*. Now perform checkout procedure 6.2 on page 42.

#### Floating Blanking Operation

With floating blanking "on", objects of up to a specified size may enter the defined area at any point without causing a "trip" condition (see Section 2.1). With floating blanking "on", the minimum object sensitivity is increased.

The use of floating blanking increases the Penetration Depth Factor ( $D_{pf}$ ) and also, therefore, the separation distance required between the defined area and the closest machine danger point. If the separation distance was calculated on the basis of no floating blanking and you later begin to use floating blanking, OSHA regulations require the separation distance to be increased accordingly. See Section 3.2.1.

*Upon power-up (and also at every shift change or machine setup change), checkout procedure 6.3 on page 44 must be performed.*

*\* If floating blanking is "on", the green LED will be flashing.*

### 5. Troubleshooting and Maintenance

#### 5.1 Troubleshooting Lockout Conditions

A MINI-SCREEN System lockout condition occurs:

- 1) Routinely upon MINI-SCREEN System "power-up" (unless Auto Power-up is "on", see Section 4.3),
- 2) If power to the MINI-SCREEN System is interrupted, unless Auto Power-up is "on",
- 3) If the control box key switch is in the RESET position, at power-up (with auto power-up "on"), or if the key switch is switched to RESET while the system is in the RUN mode,
- 4) If an FSD (Final Switching Device) relay does not "drop out" within its specified time,
- 5) If the SSD (Secondary Switching Device) relay has de-energized,
- 6) If the controller module switch settings are inconsistent with each other or are changed while the system is in RUN mode,
- 7) If the self-checking circuits of the microprocessor detect a component failure within the MINI-SCREEN System itself.

A lockout condition causes all output relays (FSD1, FSD2, and SSD) plus the auxiliary monitor relay to open, shutting down the MPCEs and MSCE of the guarded machine. A lockout condition resulting from an internal system fault is indicated by the red status LED (only) flashing.

Power-up/power interrupt lockouts (Auto Power-up "off", conditions #1 or 2 above, yellow LED only double-flashing) are normal and require a key reset for operation to continue.

Use the following procedure to resume operation after a power interruption (condition #2):

- a) Turn the key to the RESET position (yellow Status Indicator LED should light) and wait at least one-half second, then
- b) Turn the key to the RUN position:  
If defined area is clear and the emitter and receiver are properly aligned, the green and yellow LEDs will light.

If the lockout condition was due to a momentary power interruption that has been corrected, the MINI-SCREEN System will now operate normally.

*Upon recovery from a power interruption, checkout procedure 6.3 on page 44 must be performed.*



#### **WARNING. . .**

Power failures or other MINI-SCREEN System lockout conditions should always be investigated immediately by a qualified person. *With the exception of lockout conditions #1 and #2 (left), lockout is a positive indication of a problem and should be investigated at once. Attempts to operate machinery by bypassing the MINI-SCREEN System are dangerous and could result in serious bodily injury or death.*



#### **WARNING. . .**

.Dangerous voltages are present inside the MINI-SCREEN System control box whenever ac power to the system and/or machine control elements is "on". **Exercise extreme caution whenever the control box cover is open and ac voltage is or may be present!**

If the Status Indicator LEDs will not operate, the lockout condition is due to another cause (conditions #3-7). In this case, the qualified person must note the state of the Diagnostic Indicator LEDs (refer to Fig. 24, below). If one or more of the red Diagnostic Indicator LEDs is "on", the cause of the lockout condition is *within* the MINI-SCREEN System. The MINI-SCREEN System will not operate if its self-checking circuits have detected an internal problem. Take the corrective measure(s) shown in Figure 24 for the listed Error Number and related Problem. If further assistance is required, contact your Banner field service engineer or the factory Applications Engineering Department.

If no Diagnostic Indicator LEDs are "on", power to the system *may* have been lost. The green LED on the power supply board (see Figure 20, page 25) indicates the presence (LED "on") or absence (LED "off") of **dc power at the power supply board**. It is possible for **power** to be present at the input of the power supply even if the dc power LED is "off". **Exercise care. A shock hazard may exist under these conditions.**

**Very carefully check for voltage across the L and N (or + and -) terminals of wiring barrier TB1.** If voltage is **not** present at L and N, power to the MINI-SCREEN System has been lost, and the cause is outside the system. Check for 12V dc at connector block TB3. If 12V dc is **not** present there, turn off the power to the control box and check the fuse. If the fuse is bad, replace it (Section 5.3.1). If the fuse is good, and 12V dc is still **not** present at TB3, a power supply failure has occurred.

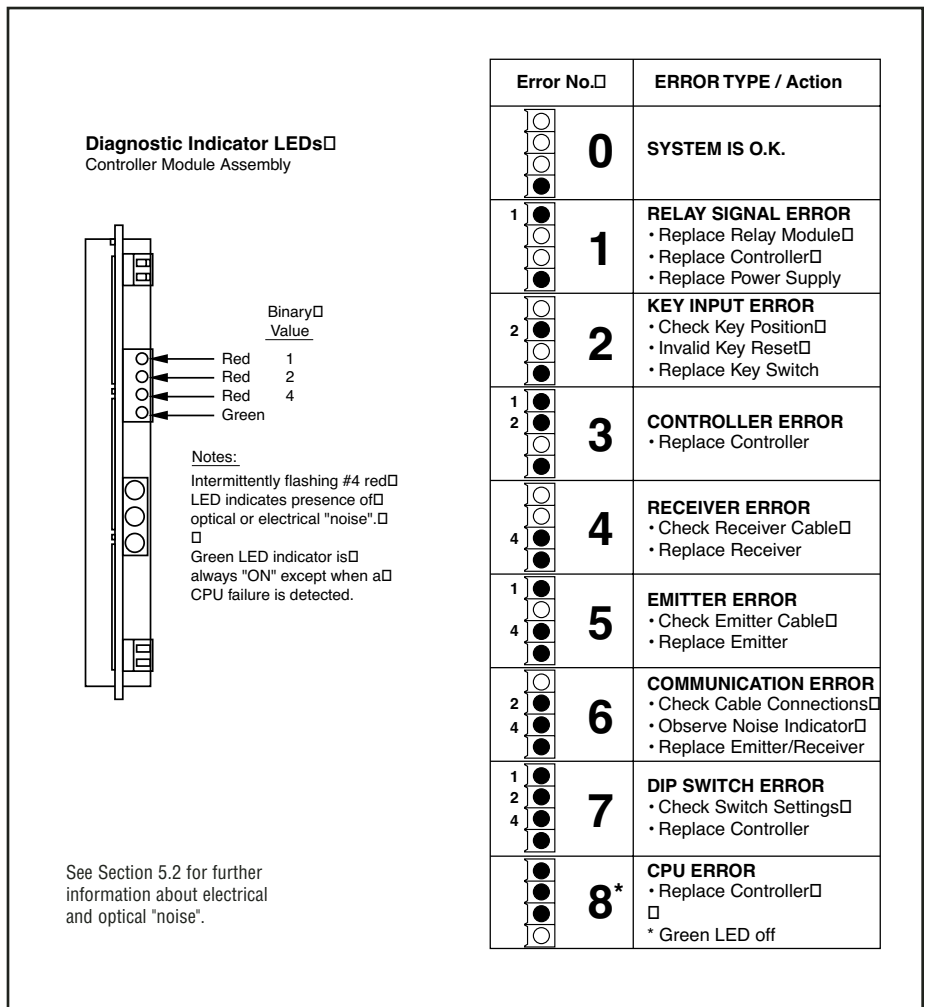

Figure 24. Interpretation of Diagnostic Indicator LEDs

### 5.2 Effects of Electrical and Optical Noise

The MINI-SCREEN System is designed and manufactured to be highly resistant to "noise" and to operate reliably in industrial settings. However, serious electrical and/or optical "noise" may cause a random "trip" condition. In *very extreme cases*, a "lockout" is possible. In order to minimize the effects of transitory noise, the MINI-SCREEN System will respond to noise only if the noise is detected on multiple consecutive scans. Red Diagnostic Indicator LED #4 will flash to indicate the presence of electrical or optical noise. This LED can be used to track down particularly offensive noise sources (see sidebar). Simply observe the LED while shutting down or isolating the suspected sources.

Whenever a remote accessory (such as the MGA-KSO-1 Remote Key Switch) is used with the MINI-SCREEN System, use of shielded cable or a separate grounded conduit is recommended.

### 5.3 Servicing and Maintenance

#### 5.3.1 Fuse Test and Replacement

**Turn off ac power to the control box before proceeding.**

The MINI-SCREEN System control box fuse is located in a fuseholder on the power supply board (see Figure 20, page 25). Remove the fuse from the holder. Visually inspect the fuse and/or test its conductivity using an ohm meter or a continuity tester. The fuse is a 3AG or 5x20 mm slow-blow type (see specifications, page 53).

#### 5.3.2 Controller Module and Relay Replacement

MINI-SCREEN Systems are designed for reliability. While replacement of the controller module and relays is not normally required, these components have been designed to be easily replaceable as a convenience to the customer. **To maintain control reliability, use only Banner-supplied replacement relays with forced-guided contacts.**

The controller module may be removed from the control box by gently "rocking" the board to loosen it and then sliding the board out of the box. To re-install the controller module, slide the board into place until snug, then push it into place.

#### Electrical and Optical Noise

Check the following if red Diagnostic Indicator LED #4 is flashing:

- Poor connection between control box and earth ground
- Drain wire of emitter and/or receiver not connected to TB3 (see Figure 20)
- Sensor wires or output wires routed too close to "noisy" wiring
- Optical interference from adjacent light curtains or other photoelectrics



#### WARNING . . .

Servicing the MINI-SCREEN System while the hazardous machinery is operational could result in serious bodily injury or death. You may be working close to the hazardous area of your machinery while servicing the MINI-SCREEN System.

**The machinery that the MINI-SCREEN System is connected to must not be operating at any time during this procedure.**



#### CAUTION . . .

Electrical shock hazard exists when the MINI-SCREEN System has power applied to it and/or the machine control elements and the control box door is open. Use extreme caution to avoid electrical shock during installation or servicing or when the control box door is open to change programming or observe the diagnostic indicators. **Always disconnect all power from the MINI-SCREEN System and the guarded machine before making any wire connections or before replacing any component.**

**The control box should be opened and/or serviced only by a qualified person (see Section 4.1).**



### **WARNING. . .**

If replacement parts are ever required, **always use only genuine Banner-supplied replacement parts** (see page 55). Do not attempt to substitute parts from another manufacturer. To do so could impair the operation of the MINI-SCREEN System and could result in serious bodily injury or death.

The output relays are configured on one module (see Figure 20, page 25). To remove the module, remove the 3/8" nylon hex nuts and gently slide the module out of the control box to disconnect it from the mother board. To reinstall, press the module firmly and evenly onto its connector pins and replace the hex nuts. Use care to avoid overtightening.

**NOTE: Do not open the emitter or receiver housing. The emitter and receiver contain no field-replaceable components.** If repair is necessary, return the unit to the factory. Do not attempt to repair an emitter or receiver yourself.

**If it ever becomes necessary to return any MINI-SCREEN component to the factory, pack it carefully.**

**Return to:  
Repair Department  
Banner Engineering Corp.  
715 North County Road 19  
Aberdeen, SD 57401**

***Damage that occurs in return shipping is not covered by warranty.***

### **5.3.3 Cleaning**

**The MINI-SCREEN System control box** is constructed of welded steel with a black polyester paint finish, and is rated NEMA 13 (IP 64). It may be cleaned using mild detergent or window cleaner and a soft cloth.

**The MINI-SCREEN System emitter and receiver units** are constructed of aluminum with a black anodized finish and are rated NEMA 4, 13 (IP65). Lens covers are acrylic. Emitters and receivers are best cleaned using mild detergent or window cleaner and a soft cloth. Avoid cleaners containing alcohol, as they may damage the acrylic lens covers.

## 6. Alignment and Checkout Procedures

Study each procedure from beginning to end to make sure that you understand each step before you start. Refer all questions to the Banner Applications Engineering Department (address, telephone, and FAX information on page 2).

Section 6.1 is a procedure for optically aligning a MINI-SCREEN System. Sections 6.2, 6.3, and 6.4 are periodic performance checkout procedures for the MINI-SCREEN System, and are performed according to the schedule given in Section 4.2.

### 6.1 MINI-SCREEN System Alignment

This alignment procedure begins with the assumption that the MINI-SCREEN System has been mechanically aligned as described in Section 3.3.

Follow the measures outlined below to maximize MINI-SCREEN System excess gain. If there are reflective surfaces near the defined area, read alignment step #5 (page 40) before proceeding further, to prevent possible reflection problems.

Only a **qualified person** may align the MINI-SCREEN System, as follows:

- 1) Turn off power to the MINI-SCREEN System and to the guarded machine. Leave power to the guarded machine "off", and power-up the MINI-SCREEN System only.
- 2) The MINI-SCREEN will power up into a *power-up lockout condition* (unless Auto Power-up is "on"). Remove all obstructions from the defined area and reset the MINI-SCREEN System as follows:
  - a. Turn the control box front-panel key reset switch to the RESET position,
  - b. Leave the key in the RESET position for at least 1/2 second to allow time for internal system checks, and
  - c. Turn the key switch to the RUN position.



#### WARNING. . .

You may be working close to the hazardous area of your machinery while aligning the MINI-SCREEN System. Aligning the MINI-SCREEN System while the hazardous machinery is operational could result in serious bodily injury. ***The machinery that the MINI-SCREEN System is connected to must not be operating at any time during the alignment procedure of Section 6.1.***

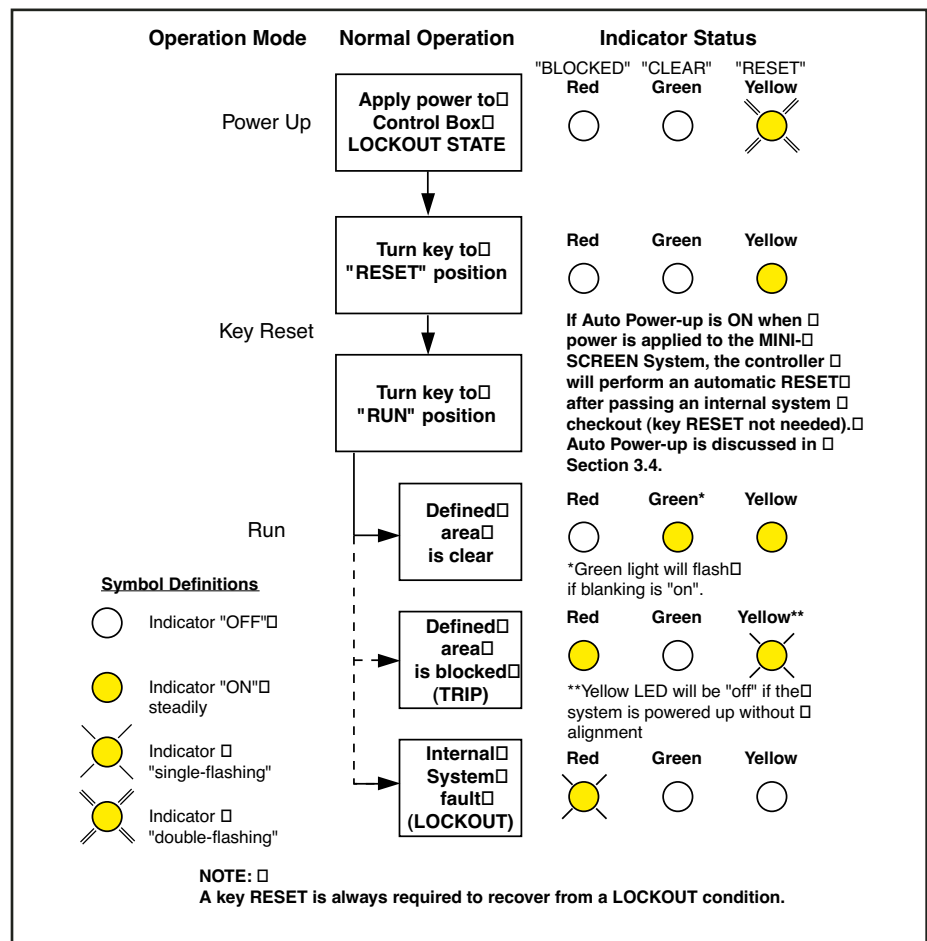

Figure 25. Operating Status LED Conditions

- 3) Upon completion of the key RESET (step #2), the MINI-SCREEN will indicate either a BLOCKED or a CLEAR condition:
  - a) A BLOCKED condition is indicated by the red LED “on” steadily and the yellow LED flashing at a rate which is proportional to the number of beams which are aligned and unblocked. Go to step #4.  
  
  - b) A CLEAR condition is indicated by the red LED “off”, and the green and yellow LEDs “on” steadily. Further alignment is not necessary.
- 4) A BLOCKED condition after RESET indicates that one or more of the beams is misaligned or interrupted. When this occurs:
  - a) Check carefully for any obstructions in the path of the beams within the defined area (the limits of which are indicated by yellow arrows on the front face of the emitter and receiver - see Figure 15).
  - b) If the defined area is completely clear of obstructions, loosen the two slotted hex head M4 bolts and the M30 nut on the cable end which fasten the receiver to its mounting brackets. Slowly rotate the receiver first to the right and then to the left while watching the LED indicators at the base of the receiver.
  - c) If the green LED does not come “on”, regardless of angular position of the receiver, then loosen the emitter and rotate both relative to each other until the green LED comes “on”. Secure the emitter and receiver in the center of the area of rotation where the yellow and green LEDs are “on” steadily. *Note: The green status LED will flash if floating blanking is “on”.*
  - d) If the green LED still fails to come “on”, then re-check the sensor mounting per the procedure in Section 3.3, and then re-align per this alignment procedure.
- 5) "Trip test" the MINI-SCREEN System for object detection capability using the test piece(s) supplied with the control box. To perform this test, the key switch must be in the RUN position and the green and yellow LEDs (only) must be "on". Reset the system (key reset), if necessary, to attain this condition.

Use the .75-inch diameter specified test piece, model STP-2, if the floating blanking feature is “off” and 9 m (30 ft) sensors are in use. Use the 1.00 inch diameter specified test piece, model STP-7, if the floating blanking feature is “off” and 18 m (60 ft) sensors are in use.

Use the 1.75-inch diameter specified test piece, model STP-3, if the floating blanking feature is “on” and 9 m (30 ft) sensors are in use. Use the 2.00 inch diameter specified test piece, model STP-8, if the floating blanking feature is “on” and 18 m (60 ft) sensors are in use. The appropriate test pieces are supplied with each control box.

## Alignment & Checkout

Perform the trip test as follows:

Pass the appropriate specified test piece downward through the defined area at three points (see Figure 26):

- a) close to the receiver,
- b) close to the emitter, and
- c) midway between the emitter and receiver.

In each case, the red indicator must come “on” and the green indicator must go “off” and remain “off” for as long as the test piece is within the defined area. If the green indicator comes “on” at any time when the test piece is within the defined area, the cause may be from light reflected from the emitter to the receiver by a nearby reflective surface (see Caution on page 18). If a reflective surface can be identified, move either the defined area (i. e. - move the sensors) or the reflective surface. Be sure to maintain at least the minimum required separation distance (see Section 3.2.1). Alternately, take measures to reduce the reflectivity of the interfering surface (i. e. by angling, painting, masking, etc.).



### WARNING. . .

If the MINI-SCREEN System does not respond properly to the trip test, do not attempt to use the System. If the MINI-SCREEN System does not respond properly to the trip test, it cannot be relied upon to stop dangerous machine motion when a person or object enters the defined area. Serious bodily injury or death could result.

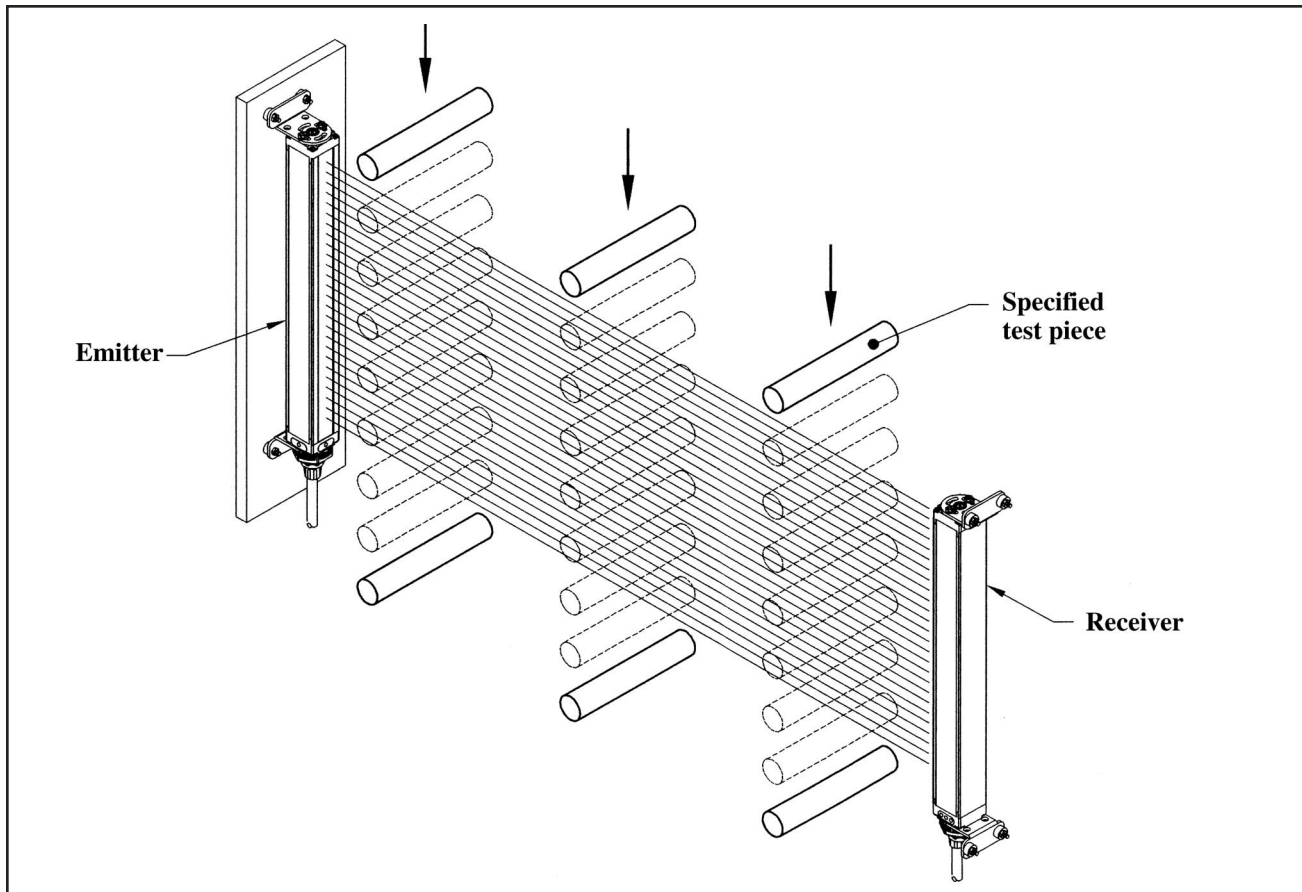

Figure 26. MINI-SCREEN Trip Test.



## Use of Corner Mirrors

MINI-SCREEN sensors may be used with one or more MSM Series corner mirrors for guarding along more than one side of an area.

The Accessories section lists the 12 available lengths of corner mirrors (see page 58). These are rear-surface glass mirrors which are rated at 85 percent efficiency. Sensing range (and therefore excess gain) is reduced when using mirrors. The following table lists the resultant range when using from one to four MSM Series corner mirrors in either sensing path.

Number of MSM Series Mirrors				
	1	2	3	4
9 meter (30 ft) range sensors	28 ft (8.5 m)	25.5 ft (7.8 m)	23.5 ft (7.2 m)	22 ft (6.7 m)
18 meter (60 ft) range sensors	55 ft (16.8 m)	51 ft (15.5 m)	47 ft (14.3 m)	43 ft (13.1 m)

Mirrors should be securely mounted to a solid surface that is free from vibration. Using a level, mount the mirror(s) exactly parallel to (i.e. in the same plane as) its (their) sensors, with the midpoint of the mirror(s) directly in line with the midpoint of the sensor's defined area. The upper and lower limits of the defined area of MINI-SCREEN sensors is marked by arrows along the edge of each sensor window, and is dimensioned in the chart on page 21.

Adjust the corner mirror(s) so that the angle of incidence of light to the mirror equal the angle of reflection from the mirror. Referring to Figure 27, below, sight from behind one of the sensors directly towards the mirror (or the first mirror in line). When alignment is correct, you will see the straight and centered reflection of the lens of the other sensor in the mirror.

Use the yellow alignment indicator corresponding to the screen being aligned for final alignment. Refer to the data sheet (P/N 43658) packed with each MSM Series corner mirror for complete information on the use of corner mirrors.



### WARNING . . .

Supplemental presence sensing devices, such as safety mats, must be used if any space between either defined area and any danger point is large enough to allow a person to stand undetected by the MINI-SCREEN System. Failure to observe this warning could result in serious injury or death.

See, also, the warning on page 30 regarding use of the MINI-SCREEN System for perimeter guarding.

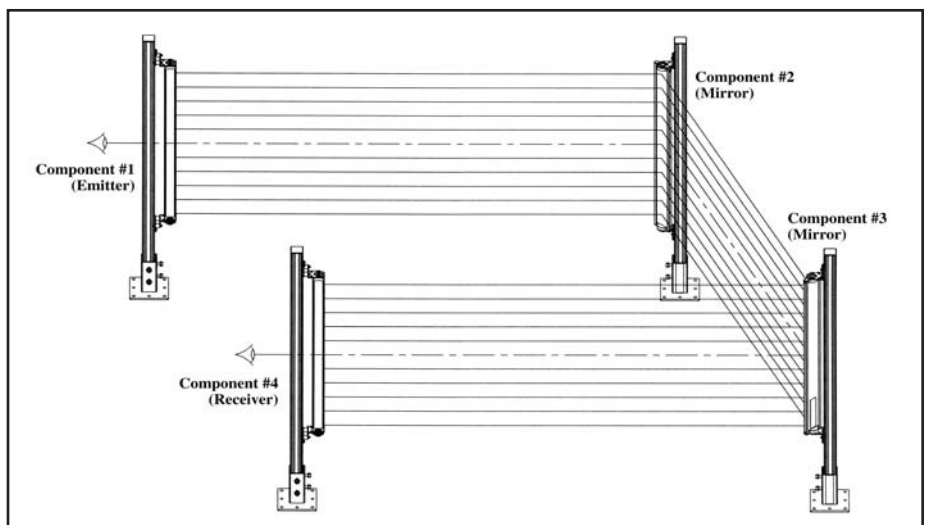

Figure 27. Corner Mirror Alignment

## Alignment & Checkout

### 6.2 Commissioning Checkout to be Performed at Time of Installation

This commissioning checkout must be done by a *qualified person* who possesses all of the manufacturer-provided information on the MINI-SCREEN® System and guarded machine and who, by possession of a recognized degree or certificate of professional training or who, by extensive knowledge, training, or experience, has successfully demonstrated the ability to solve problems relating to the installation, operation, and maintenance of optoelectronic machine guards.

A copy of checkout results should be kept in the employer's files: see OSHA 1910.217(e)(1).

#### The *qualified person* must:

- 1) Examine the guarded machine to verify that it is of a type and design that is compatible with the MINI-SCREEN System. See page 2 for a list of misapplications.
- 2) Verify that the minimum separation distance from the closest danger point of the guarded machine to the defined area is not less than the calculated distance (see figure 28, below).
- 3) Verify that access to the dangerous parts of the guarded machine is not possible from any direction not protected by the MINI-SCREEN System, hard guarding, or supplemental guarding, and verify that all supplemental guarding devices and hard guarding are in place and operating properly.
- 4) Verify that it is not possible for a person to stand between the defined area and the dangerous parts of the guarded machine. Or, verify that supplemental presence sensing devices, such as safety mats, are in place and functioning properly in any space between the defined area and any danger point which is large enough to allow a person to stand undetected by the MINI-SCREEN System.



#### WARNING. . .

**A shock hazard exists while the lockable enclosure is open. Before continuing, verify that the enclosure is closed and latched.**

The formula used to calculate the separation distance is:

$$D_s = K \times (T_s + T_r) + D_{pf}$$

where:

**D<sub>s</sub>** = the separation distance;

**K** = the OSHA-recommended hand speed constant of 63 inches per second (NOTE 1, below);

**T<sub>s</sub>** = the overall stop time of the machine measured from the application of the "stop" signal to the final ceasing of all motion (including stop times of all relevant control elements, and measured at maximum machine velocity). See NOTE 2, below.

**T<sub>r</sub>** = the response time of the MINI-SCREEN System:  
.048 seconds for 4.5 to 16 inch emitter/receiver,  
.060 seconds for 20 to 32 inch emitter/receiver  
.072 seconds for 36 to 48 inch emitter/receiver

**D<sub>pf</sub>** = the added distance due to depth penetration factor, as prescribed in OSHA 1910.217 and ANSI B11 standards:  
D<sub>pf</sub> = 1.6 inches with floating blanking "off" when using 9 m (30 ft) range sensors  
D<sub>pf</sub> = 2.5 inches with floating blanking "off" when using 18 m (60 ft) range sensors  
D<sub>pf</sub> = 5.0 inches with floating blanking "on" when using 9 m (30 ft) range sensors  
D<sub>pf</sub> = 5.9 inches with floating blanking "on" when using 18 m (60 ft) range sensors

#### NOTES:

- 1) The OSHA-recommended hand-speed constant K has been determined by various studies, and although these studies indicate speeds of 63 in/sec to over 100 in/sec, they are not conclusive determinations. The employer should consider all factors, including the physical ability of the operator, when determining the value of K to be used.
- 2) T<sub>s</sub> is usually measured by a stop-time measuring device. If the specified machine stop time is used, we recommend that at least 20% be added as a safety factor to account for clutch/brake system deterioration.
- 3) Use of floating blanking will always cause the required D<sub>s</sub> to increase.



#### WARNING. . .

Calculate the separation distance carefully. Failure to maintain appropriate separation distance can result in serious bodily injury or death.

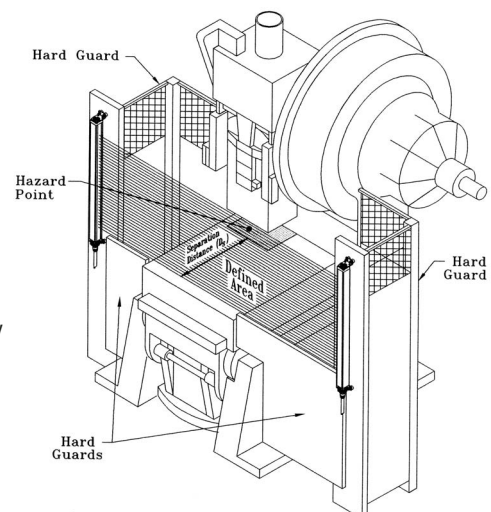

Figure 28. Calculation of D<sub>s</sub>

- 5) Examine the electrical wiring connections between the MINI-SCREEN output relays and the guarded machine's control elements to verify that the requirements stated in Section 3.5.4.
- 6) Test the effectiveness of the MINI-SCREEN System with power "on", as described in steps (a) through (d), below.

The controller includes two or four specified test pieces. Select the proper test piece based on the sensors used and the system configuration, per the following chart:

Sensors	Floating Blanking	Specified Test Piece Model	Specified Test Piece Diameter
9 m (30 ft) range	Off	STP-2	19.1 mm (0.75 in)
9 m (30 ft) range	On	STP-3	44.5 mm (1.75 in)
18 m (60 ft) range	Off	STP-7	25.4 mm (1.00 in)
18 m (60 ft) range	On	STP-8	50.8 mm (2.00 in)

- a) Verify that the MINI-SCREEN System is in the RUN mode (green and yellow Status Indicator LEDs "on").
  - b) With the guarded machine at rest, pass the *specified test piece* (supplied with the control box) downward through the defined area at three points: close to the receiver column, close to the emitter column, and midway between the emitter and receiver columns (figure 29). In each case, the red indicator must come "on" and the green indicator must go "off" and remain "off" for as long as the test piece is within the defined area. If the green indicator comes "on" at any time when the test piece is within the defined area, check for reflective surfaces, and do not continue until the cause is discovered and the situation is resolved. NOTE: Latching output models require a latch reset after each pass of the test piece.
  - c) Initiate machine motion of the guarded machine and, during motion, insert the *specified test piece* into the defined area (at right angles to the defined area). *Do not attempt to insert the test piece into the dangerous parts of the machine.* Upon insertion of the test piece into the defined area at any time during machine motion, the dangerous parts of the machine should come to a stop with no apparent delay. Upon removal of the test piece from the defined area, verify that the machine does **not** automatically restart, and that the initiation devices must be engaged to restart the machine. NOTE: Latching output models require a latch reset before the initiation devices are engaged to restart the machine.
  - d) With the guarded machine at rest, insert the *specified test piece* into the defined area and verify that it is not possible for the guarded machine to be put into motion while the specified test piece is within the defined area.
- 7) Remove electrical power to the MINI-SCREEN System. All output relays should immediately de-energize, and should not be capable of being reactivated until power is re-applied and a key reset (and a latch reset for latching output models) is performed (unless the auto power-up feature is "on").
  - 8) Test the machine stopping response time using an instrument designed for that purpose to verify that it is the same or less than the overall system response time specified by the machine manufacturer. (NOTE: Banner's Applications Engineering Department can recommend a suitable instrument.)

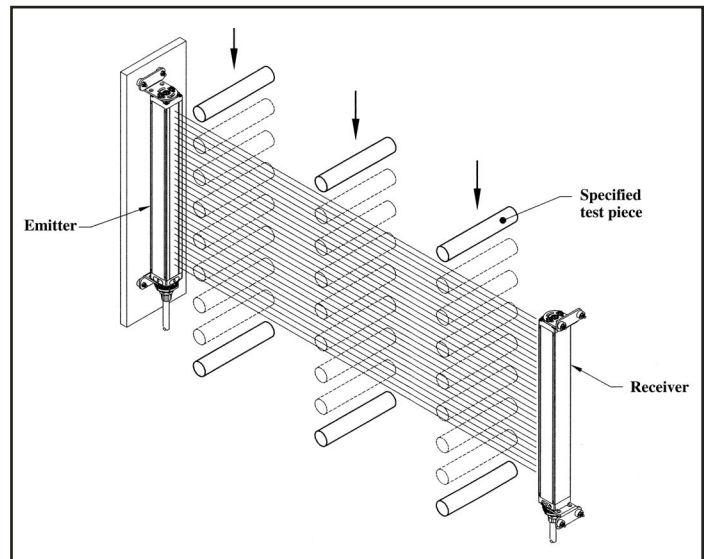

**Figure 29. Use of Test Piece**



### WARNING . . .

If *all* of the above checks cannot be verified, the MINI-SCREEN System/guarded machine should not be used until the defect or problem has been corrected (see Section 5). Attempts to use the guarded machine under such conditions could result in serious bodily injury or death.

## Alignment & Checkout - Periodic System Checks

### 6.3 To Be Performed at Every Power-up, Shift Change, and Machine Setup Change

Daily checkout and checkouts after tooling and machine changes must be performed by a *designated person* appointed and identified in writing by the employer. During continuous machine run periods, this checkout must be performed at intervals not to exceed 24 hours. A copy of checkout results should be kept on or near the machine: see OSHA 1910.217(e)(1).

#### The *designated person* must:

- 1) Verify that access to the dangerous parts of the guarded machine is not possible from any direction not protected by the MINI-SCREEN System, hard guarding, or supplemental guarding, and verify that all supplemental guarding devices and hard guarding are in place and operating properly.
- 2) Verify that the minimum separation distance from the closest danger point of the guarded machine to the defined area is not less than the calculated distance. See Section 3.2.1.
- 3) Ensure that it is not possible for a person to stand between the defined area and the dangerous parts of the guarded machine. Or, verify that supplemental presence sensing devices, such as safety mats, are in place and functioning properly in any space between the defined area and any danger point which is large enough to allow a person to stand undetected by the MINI-SCREEN System.
- 4) Verify that the enclosure for the MINI-SCREEN control module is latched and locked. The key (or combination or tool) to the locking mechanism should be in the possession of a *qualified person*.



#### **WARNING. . .**

***A shock hazard exists while the lockable enclosure is open. Before continuing, verify that the enclosure is closed and latched.***

- 5) Test the effectiveness of the MINI-SCREEN with power “on”, as described in steps (a) through (d), below.

Sensors	Floating Blanking	Specified Test Piece	
		Model	Diameter
9 m (30 ft) range	Off	STP-2	19.1 mm (0.75 in)
9 m (30 ft) range	On	STP-3	44.5 mm (1.75 in)
18 m (60 ft) range	Off	STP-7	25.4 mm (1.00 in)
18 m (60 ft) range	On	STP-8	50.8 mm (2.00 in)

- a) Verify that the MINI-SCREEN System is in the RUN mode (green and yellow Status Indicator LEDs “on”). See Section 4.3 for RESET procedure. Refer to Figure 29.
  - b) With the guarded machine at rest, pass the diameter *specified test piece* downward through the defined area at three points: close to the receiver column, close to the emitter column, and midway between the emitter and receiver columns. In each case, the red indicator must come “on” and the green indicator must go “off” and remain “off” for as long as the test piece is within the defined area. If the green indicator comes “on” at any time when the test piece is within the defined area, check for reflective surfaces (see Warning, page 45). NOTE: Latching output models require a latch reset after each pass of the test piece.
  - c) Initiate machine motion of the guarded machine and, during motion, insert the *specified test piece* into the defined area (at right angles to the defined area). *Do not attempt to insert the test piece into the dangerous parts of the machine.* Upon insertion of the test piece into the defined area at any time during machine motion, the dangerous parts of the machine should come to a stop with no apparent delay. Upon removal of the test piece from the defined area, verify that the machine does **not** automatically restart, and that the initiation devices must be engaged to restart the machine. NOTE: Latching output models require a latch reset before the initiation devices are engaged to restart the machine.
  - d) With the guarded machine at rest, insert the *specified test piece* into the defined area and verify that it is not possible for the guarded machine to be put into motion while the specified test piece is within the defined area.
- 6) Check carefully for external signs of damage to the MINI-SCREEN System, the guarded machine, and their electrical wiring. Any damage found should be immediately reported to management.

### 6.4 To Be Performed at Six Month Intervals (Semi-annually)

This semi-annual checkout must be done by a *qualified person*. A copy of test results should be kept on or near the machine.



**WARNING. . .**

*A shock hazard exists while the lockable enclosure is open. Before continuing, verify that the enclosure is closed and latched.*

**The *qualified person* must:**

- 1) Perform the Commissioning Checkout Procedure (Section 6.2). If any decrease in machine braking ability has occurred, make the necessary clutch/brake repairs, readjust  $D_S$  appropriately, and re-perform the checkout sequence of Section 6.2.
- 2) Examine and test the machine primary control elements (MPCEs) to ensure that they are functioning correctly and are not in need of maintenance or replacement.
- 3) Inspect the guarded machine to ensure that there are no other mechanical or structural problems that would prevent the machine from stopping or assuming an otherwise safe condition when signalled to do so by the MINI-SCREEN System.
- 4) Examine and inspect the machine controls and connections to the MINI-SCREEN System to ensure that no modifications have been made which adversely affect the system.



**WARNING. . .**

If *all* of the above checks cannot be verified, the MINI-SCREEN System/guarded machine should not be used until the defect or problem has been corrected (see Section 5 ). Attempts to use the guarded machine under such conditions could result in serious bodily injury or death.



**WARNING – Reflective Surfaces. . .**

It may be possible for a highly reflective surface (such as a shiny machine surface or a shiny workpiece) to reflect sensing light around an object in the defined area, thus preventing that object from being detected. This potentially dangerous condition is discovered using the “trip test” as described in the Initial Checkout Procedure (Section 3.5.3), the Alignment Procedure (Section 6.1), and the periodic checkout procedures (Sections 6.2, 6.3, and 6.4).

When this condition is discovered, eliminate the problem reflection(s). If possible, relocate the sensors to move the curtain of light beams away from the reflective surface(s). If relocating the sensors, be careful to retain at least the required separation distance (Section 3.2.1). Otherwise, paint, mask, or roughen the interfering shiny surface to reduce its reflectivity. Use the trip test to verify that these changes have eliminated the problem reflection(s).

NOTE: If the workpiece is especially reflective and comes close to the curtain, perform the trip test with the shiny workpiece in place.

### Glossary of Terms

Terms shown in *italics* in the definitions below are themselves defined elsewhere in the glossary.

**ANSI (American National Standards Institute):** the American National Standards Institute, is an association of industry representatives which develops technical standards which include safety standards. These standards comprise a consensus from a variety of industries on good practice and design. ANSI standards relevant to application of the MINI-SCREEN System include ANSI B11.1 (mechanical power presses), ANSI B11.2 (hydraulic power presses), and ANSI/RIA R15.06 (industrial robots and robot systems). See page 56

**Auxiliary monitor or Alarm contact:** a low load capacity, non safety-related relay contact within the MINI-SCREEN System whose primary purpose is to communicate system status to a PLC.

**Auto Power-up:** a feature of the MINI-SCREEN control box which, when switched “on”, enables the MINI-SCREEN to be powered up (and recover from a power interruption) without the necessity of a *key reset*. When Auto Power-up is “on”, the MINI-SCREEN control box automatically begins internal diagnostics upon power-up, and automatically resets the system if it passes the diagnostic check. With Auto Power-up “off”, a manual reset is required.

**Control reliability:** A method of ensuring the integrity of performance of a control system. Control circuits are designed and constructed so that a single failure or fault within the system does not prevent the normal stopping action from being applied to the machine when required, or does not create unintended machine action, but does prevent initiation of successive machine action until the failure is corrected.

**Control box:** contains the circuitry (internal to the MINI-SCREEN System) that provides the proper voltages to the system, controls the sensing units, receives and processes information from the sensing units and the safety monitoring means, and provides outputs to the *Final Switching Devices (FSD1 and FSD2)*, the *Secondary Switching Device (SSD)*, and the *Auxiliary Monitor Relay*.

**Control module:** a removeable printed circuit board, located within the MINI-SCREEN System control box, which contains the microprocessors and related electronic circuits.

**Defined area:** the “curtain of light” generated by the MINI-SCREEN System. When the defined area is interrupted by an opaque object of a specified cross section, a *trip condition* results (see Figure 1).

**Designated person:** a person or persons identified and designated in writing, by the employer, as being appropriately trained and qualified to perform a specified checkout procedure.

**Diverse redundancy:** in diverse redundancy, the redundant components are of different design, and any microprocessor programs used must run from different instruction sets written by different programmers.

**Emitter:** the light-emitting component of the MINI-SCREEN System, consisting of a row of synchronized modulated infrared LEDs. The emitter, together with the *receiver* (placed opposite), creates a “curtain of light” called the *defined area*.

**Final switching device (FSD):** the two output relays (FSD1 and FSD2) of the MINI-SCREEN System which respond to an interruption of the defined area by interrupting the circuit connecting them to the *Machine Primary Control Elements (MPCEs)* of the *guarded machine*.

**Floating blanking:** a feature that allows the MINI-SCREEN System to be programmed to produce an intentionally disabled light beam, within the “curtain of light”, which appears to move up and down (“float”) in order to allow the feeding of an object through the curtain (the *defined area*) at any point along the length of the curtain without causing a *trip condition*.

The MINI-SCREEN System offers two-beam floating blanking which allows **multiple** objects (usually workpiece material) up to 0.8 inch in cross section to move through the *defined area* without tripping the *final switching devices*.

**FMEA (Failure Mode and Effects Analysis):** a testing procedure by which potential failure modes in a system are analyzed to determine their results or effects on the system. Component failure modes that produce either no effect or a *lockout condition* are permitted; failures which cause an unsafe condition (a *failure to danger*) are not. Banner MINI-SCREEN Systems are extensively FMEA tested.

**Forced-guided contacts:** relay contacts that are mechanically linked together, so that when the relay coil is energized or de-energized, all of the linked contacts move together. If one set of contacts in the relay becomes immobilized, no other contact of the same relay will be able to move. The function of forced-guided contacts is to enable the safety circuit to check the status of the relay. Forced-guided contacts are also known as “positive-guided contacts”, “captive contacts”, “locked contacts”, or “safety relays”. MINI-SCREEN Systems use output relays with forced-guided contacts.

**Full-revolution devices:** a method of machine drive arranged such that, once started, the machine can only be stopped when the full cycle is complete. Examples include positive key clutches and similar mechanisms. Banner MINI-SCREEN Systems may **not** be used with full-revolution devices.

**Guarded machine:** the machine whose point of operation is guarded by a MINI-SCREEN System, and whose *MPCEs* and *MSCE* are connected to relays *FSD1*, *FSD2*, and *SSD* of the MINI-SCREEN System.

**Hard guarding:** screens, bars, or other mechanical barriers that prevent a person from reaching over, under, or around the *defined area* of an installed MINI-SCREEN System and into the *point of operation* of the *guarded machine*.

**Internal lockout:** a lockout condition that is due to an internal MINI-SCREEN System problem. Indicated by the red Status Indicator LED (only) flashing. Requires the attention of a *qualified person*.

**Key reset:** a key-operated switch that is used to restore the *Final Switching Devices (FSDs)* and *Secondary Switching Device (SSD)* to the *ON state* from a *lockout condition*. Also refers to the act of using the switch to reset the MINI-SCREEN System.

**Lockout condition:** a condition of the MINI-SCREEN System that is automatically attained both: (1) when its ac supply mains are interrupted and restored, and (2) in response to certain failure signals. When a lockout condition occurs, the MINI-SCREEN System's *FSD*, *SSD*, and *Auxiliary Monitor Relay* contacts open, and a *key reset* is required to return the system to the RUN condition.

**Machine primary control element (MPCE):** an electrically powered element, external to the MINI-SCREEN System, which directly controls the machine's normal operating motion in such a way that it is last (in time) to operate when motion is either initiated or arrested.

**Machine response time:** the time between the interruption by the *Final Switching Devices (FSDs)* of the electrical supply to the *Machine Primary Control Element(s)* (*MPCEs*) and the instant when the dangerous parts of the machine reach a safe state by being brought to rest.

**Machine secondary control element (MSCE):** a machine control element independent of the *Machine Primary Control Element(s)* (*MPCEs*), capable of removing the source of power from the prime mover of the relevant dangerous machine parts.



**Minimum object sensitivity:** the minimum-diameter object that a light curtain system can reliably detect. Objects of this diameter or greater will be detected anywhere in the sensing field. A smaller object can pass undetected through the curtain of light if it passes exactly midway between two adjacent light beams. See also *specified test piece*.

**MPCE monitor contacts:** the normally open and normally closed contacts of a *guarded machine's MPCEs* which are connected in series with the ac power supply to the MINI-SCREEN System. Any inconsistency of action between the two sets of monitor contacts will remove power from the MINI-SCREEN System and cause a *lockout condition*. See Figure 23.

**OFF state (of Final and Secondary Switching Devices):** in the OFF state, the output circuit is broken and interrupts the flow of current.

**ON state (of Final and Secondary Switching Devices):** in the ON state, the output circuit is complete and permits the flow of current.

**OSHA (Occupational Safety and Health Administration); OSHA CFR 1910.217:** Occupational Safety and Health Administration (a US Federal agency), Division of the US Department of Labor, that is responsible for the regulation of workplace safety. OSHA regulations often follow ANSI standards, including mechanical power press requirements (OSHA CFR 1910.217). These regulations become law when adopted by OSHA, and must be followed. See page 56.

**Output relays:** the devices (within the MINI-SCREEN System) that are used to initiate an emergency stop signal. The MINI-SCREEN System's output relays (*FSD1*, *FSD2*, and *SSD*) use *forced-guided contacts*.

**Point of operation:** the area of the *guarded machine* where a workpiece is positioned and a machine function (i.e. shearing, forming, punching, assembling, welding, etc.) is performed upon it.

**Power supply board:** a removable printed circuit board which contains the power supply circuit and output relays and is located inside the MINI-SCREEN System *control module*. A green LED on the power supply board lights whenever dc power is present on the board.

**Power-up/power interrupt lockout:** a *lockout condition* of the MINI-SCREEN System that, if *Auto Power-up* is "off", occurs when the system is powered up (including upon power-up after a loss of power). Indicated by the yellow Status Indicator LED (only) flashing. Requires a *key reset* by a *designated person*.

**PSDI (Presence Sensing Device Initiation):** an application in which a presence sensing device is used to actually start the cycle of a machine. In a typical situation, an operator manually positions a part in the machine for the operation. When the operator moves out of the danger area, the presence sensing device starts the machine (i.e. no start switch is used). The machine cycle runs to completion, and the operator can then insert a new part and start another cycle. The presence sensing device continually guards the machine. Single break mode is used when the part is automatically ejected after the machine operation. Double break mode is used when the part is both inserted (to begin the operation) and removed (after the operation) by the operator. PSDI is defined in OSHA CFR 1910.217. *Banner MINI-SCREEN Systems may not be used as PSDI devices on mechanical power presses, per OSHA regulation 29 CFR 1910.217.*

**Qualified person:** a person or persons who, by possession of a recognized degree or certificate of professional training, or who, by extensive knowledge, training, and experience, has successfully demonstrated the ability to solve problems relating to the subject matter and work (ANSI B30.2-1983).

**Receiver:** the light-receiving component of the MINI-SCREEN System, consisting of a row of synchronized phototransistors. The receiver, together with the *emitter* (placed opposite), creates a “curtain of light” called the *defined area*.

**Secondary switching device (SSD):** the output relay of the MINI-SCREEN System which, in a *lock-out condition*, interrupts the circuit connecting it to the *Machine Secondary Control Element (MSCE)*.

**Self-checking (circuitry):** a circuit with the capability to electronically verify that all of its own critical circuit components, along with their redundant backups, are operating properly. Banner MINI-SCREEN Systems are self-checking.

**Separation distance:** that distance, along the direction of approach, between the outermost position at which the appropriate test piece will just be detected and the nearest dangerous machine parts.

**Single-stroke press:** see *full-revolution devices*.

**Specified test piece:** an opaque object of the minimum cross section required to place the MINI-SCREEN System into a *trip condition* or a *latch condition* when inserted into any part of the *defined area*. See also *minimum object sensitivity*.

**Supplemental guarding:** additional electrosensitive safety device(s), possibly employed along with *hard guarding* measures, used for the purpose of preventing a person from reaching over, under, or around the *defined area* of an installed MINI-SCREEN System and into the *point of operation* of the *guarded machine*.

**Trip condition:** the response of the *Final Switching Device (FSD)* relays when an object equal to or greater than the diameter of the *specified test piece* enters the *defined area*. In a trip condition, FSD1 and FSD2 simultaneously de-energize and open their contacts. A trip condition clears automatically when the object is removed from the defined area.

**UL (Underwriters Laboratory):** a third-party organization which tests a manufacturer's products for compliance with appropriate Standards, electrical and/or safety codes. Compliance is indicated by their listing mark on the product.

# Specifications

Product Specifications							
Models	Defined Area		Number of Beams	Models	Defined Area		Number of Beams
	(in)	(mm)			(in)	(mm)	
<b>MSE424</b> emitter <b>MSE424</b> receiver	4.5	114	8	<b>MSE2824</b> emitter <b>MSR2824</b> receiver	28	711	56
<b>MSE824</b> emitter <b>MSR824</b> receiver	8.5	215	16	<b>MSE3224</b> emitter <b>MSR3224</b> receiver	32	813	64
<b>MSE1224</b> emitter <b>MSR1224</b> receiver	12	305	24	<b>MSE3624</b> emitter <b>MSR3624</b> receiver	36	914	72
<b>MSE1624</b> emitter <b>MSR1624</b> receiver	16	406	32	<b>MSE4024</b> emitter <b>MSR4024</b> receiver	40	1016	80
<b>MSE2024</b> emitter <b>MSR2024</b> receiver	20	508	40	<b>MSE4424</b> emitter <b>MSR4424</b> receiver	44	1118	88
<b>MSE2424</b> emitter <b>MSR2424</b> receiver	24	610	48	<b>MSE4824</b> emitter <b>MSR4824</b> receiver	48	1219	96
<b>Emitter/receiver separation:</b>	6 inches (15 cm) to 30 feet (9 m) for standard sensors 6 inches (15 cm) to 60 feet (18 m) for optional long-range sensors						
<b>Minimum object sensitivity:</b>	19.1 mm (0.75 in) with 9 m (30 ft) range sensors and floating blanking "off" 44.5 mm (1.75 in) with 9 m (30 ft) range sensors and floating blanking "on" 25.4 mm (1.00 in) with 18 m (60 ft) range sensors and floating blanking "off" 50.8 mm (2.00 in) with 18 m (60 ft) range sensors and floating blanking "on"						
<b>Response time:</b>	Less than 48 milliseconds using emitter/receiver with 4.5 to 16 inch defined area Less than 60 milliseconds using emitter/receiver with 20 to 32 inch defined area Less than 72 milliseconds using emitter/receiver with 36 to 48 inch defined area						
<b>Self-checking interval:</b>	20 milliseconds						
<b>Ambient light immunity:</b>	>10,000 lux at 5° angle of incidence						
<b>Strobe light immunity:</b>	Totally immune to one Federal Signal Corp. "Fireball" model FB2PST strobe.						
<b>Emitter elements:</b>	Infrared LEDs; 880nm peak emission						
<b>Enclosures: Emitter and receiver:</b>	<i>Size:</i> see Figure 15, page 21 <i>Material:</i> Aluminum, with black anodized finish; acrylic lens cover <i>Rating:</i> NEMA 4, 13 (IP 65)						
<b>Control box:</b>	<i>Size:</i> see Figure 17, page 22 <i>Material:</i> Welded steel box with black polyester powder paint finish <i>Rating:</i> NEMA 13 (IP 64)						
<b>Mounting hardware:</b>	Emitter and receiver are each supplied with a pair of mounting brackets. Mounting brackets are 11-gauge cold-rolled black zinc chromate finished steel. A set of four vibration dampening mounts is also supplied.						



LISTED  
Presence  
Sensing  
Device  
10Y8



Certified in compliance with  
British Standard BS6491  
Parts I & II

IEC 1496-1, -2  
EN 50100-1, -2

Product Specifications - Control Module	
<b>System power requirements</b>	Control box <b>MSCA-1</b> : 115V ac $\pm 15\%$ (50/60Hz), 55 VA; Control box <b>MSCB-1</b> : 230V ac $\pm 15\%$ (50/60Hz), 55 VA; Control box <b>MSCT-1</b> : 24V dc $\pm 15\%$ , 10% maximum ripple, 1.5 amps max.
<b>Fuse rating</b>	Control box <b>MSCA-1</b> : 1/2 amp, 250V (3AG or 5x20 mm slow blow); Control box <b>MSCB-1</b> : 1/4 amp, 250V (3AG or 5x20 mm slow blow); Control box <b>MSCT-1</b> : 2 amp, 250V (3AG or 5x20 mm slow blow)
<b>Status indicators (on control box and receiver)</b>	<p><u>Red</u> = BLOCKED    Flashing red = LOCKOUT  <u>Green</u> = CLEAR    Flashing green = BLANKING "on"  <u>Yellow</u> = RESET    Double-flashing yellow = waiting for power-up manual key reset</p> <p>ALIGNMENT Single-flashing yellow = alignment indicator: flash rate increases with the number of sensing beams "made"; solid yellow when aligned and defined area is clear.</p> <p>Emitter has green LED to indicate power"on".</p>
<b>Diagnostic indicator</b>	Four LEDs indicate 8 system status conditions (see Fig. 24, page 35). Diagnostic LEDs are visible through a window in the control box cover.
<b>Controls and adjustments</b>	Keyed RESET of system lockout conditions BLANKING selection switches AUTO POWER UP on-off switches
<b>Test input</b>	Terminals must be closed for a minimum of 0.05 seconds in order to guarantee a test input signal. The switching device used must be capable of switching 15-50V dc at 20 to 100 mA.
<b>Auxiliary monitor relay</b>	Reed relay; 125V ac or dc max., 500 mA. max. (10VA maximum, resistive load)
<b>Output configuration (FSD1, FSD2, and SSD)</b>	Forced-guided contact relays, 250V ac max., 4 amps max. (resistive load). <i>Mechanical life</i> 10,000,000 operations (minimum). <i>Electrical life</i> (at full rated load) 100,000 operations (typical). <i>Arc suppression is recommended when switching inductive loads.</i> <i>See Figure 23, page 30.</i>
<b>Operating temperature</b>	0 to +50°C (+32 to 122°F)
<b>Relative humidity</b>	95% maximum (non-condensing)
<b>FMEA tested:</b> (Failure Mode and Effects Analysis)	Per requirements of proposed first edition of UL 491 Standard and BS6491.
<b>Cables:</b>	<i>NOTE: Use only Banner cables, which incorporate a "twisted pair" for noise immunity on RS485 data communication lines. Use of other cables can result in "nuisance" lockouts.</i> Emitter and receiver cables are ordered separately. Banner 5-conductor shielded cables have a straight QD (Quick Disconnect) connector molded onto the sensor end. Cables measure .32inch (8,1 mm) in diameter, and are shielded and PVC-jacketed. Conductors are 20-gauge. Two liquid-tight cable gland/strain relief fittings are supplied with each control box to admit the emitter and receiver cables through the selected knockouts on the control box wall. Emitter and receiver cable lengths may not exceed 50 feet (each). See <i>Cables</i> , page 54. <b>See cable and sensor drawing, page 22 .</b>

## Models & Accessories

### Ordering Information

MINI-SCREEN Systems are sold as kits which include a control box, an emitter and receiver of equal length, emitter and receiver mounting hardware, and two quick-disconnect cables. Cables are interchangeable between the emitter and the receiver. Components are also available separately (below).

MINI-SCREEN Emitters (E) and Receivers (R)*				
Defined Area	Models			Number of Beams
	Black Anodized	Yellow Painted		
	Range - 9 m (30 ft)	Range - 9 m (30 ft)	Range - 18 m (60 ft)	
114 mm (4.5 in)	MSE424 MSR424	MSE424Y MSR424Y	MSXLE424Y MSXLR424Y	8
215 mm (8.5 in)	MSE824 MSR824	MSE824Y MSR824Y	MSXLE824Y MSXLR824Y	16
305 mm (12 in)	MSE1224 MSR1224	MSE1224Y MSR1224Y	MSXLE1224Y MSXLR1224Y	24
406 mm (16 in)	MSE1624 MSR1624	MSE1624Y MSR1624Y	MSXLE1624Y MSXLR1624Y	32
508 mm (20 in)	MSE2024 MSR2024	MSE2024Y MSR2024Y	MSXLE2024Y MSXLR2024Y	40
610 mm (24 in)	MSE2424 MSR2424	MSE2424Y MSR2424Y	MSXLE2424Y MSXLR2424Y	48
711 mm (28 in)	MSE2824 MSR2824	MSE2824Y MSR2824Y	MSXLE2824Y MSXLR2824Y	56
813 mm (32 in)	MSE3224 MSR3224	MSE3224Y MSR3224Y	MSXLE3224Y MSXLR3224Y	64
914 mm (36 in)	MSE3624 MSR3624	MSE3624Y MSR3624Y	MSXLE3624Y MSXLR3624Y	72
1016 mm (40 in)	MSE4024 MSR4024	MSE4024Y MSR4024Y	MSXLE4024Y MSXLR4024Y	80
1118 mm (44 in)	MSE4424 MSR4424	MSE4424Y MSR4424Y	MSXLE4424Y MSXLR4424Y	88
1219 mm (48 in)	MSE4824 MSR4824	MSE4824Y MSR4824Y	MSXLE4824Y MSXLR4824Y	96

### Control Boxes

<b>MSCA-1</b>	115V ac control box (One per system)	37931
<b>MSCB-1</b>	230V ac control box (One per system)	37932
<b>MSCT-1</b>	24V dc control box (One per system)	43536

### Cables (Two required per system)\*

<b>QDC-515C</b>	4.5 m (15 ft) cable, straight QD connector. One cable per sensor.
<b>QDC-525C</b>	7.6 m (25 ft) cable, straight QD connector. One cable per sensor.
<b>QDC-550C</b>	15 m (50 ft) cable*, straight QD connector. One cable per sensor.

\* Contact factory Applications Department for information on cable lengths greater than 50 feet.

### Pigtail Quick Disconnect Option

Any yellow emitter or receiver may be ordered with a 305 mm (12 in) cable pigtail terminated in the 5-pin male mini-style quick disconnect connector. This option accommodates requirements for right-angle exit of the cable from the base of the emitter and receiver. The same mating quick disconnect cables, as listed on page 54, are used (ordered separately). To specify a pigtail quick disconnect cable, add suffix "P" to the model number of the emitter or receiver, for example: **MSE1624YP**.

**Light Screen Kits Which Include Model MSCA-1 115V ac Control Box**

Defined Area	Black Anodized Emitters and Receivers with 9-meter (30-foot) Sensing Range (Available in Yellow Painted Finish by adding "Y" at end of model number e.g. MSKA424C1Y)			Yellow Painted Emitters and Receivers with 18-meter (60-foot) Sensing Range		
	Two - 15-ft Cables	Two - 25-ft Cables	One - 15-ft Cable & One - 25-ft Cable	Two - 15-ft Cables	Two - 25-ft Cables	One - 15-ft Cable & One - 25-ft Cable
114 mm (4.5 in)	MSKA424C1	MSKA424C2	MSKA424C3	MSXLKA424C1Y	MSXLKA424C2Y	MSXLKA424C3Y
215 mm (8.5 in)	MSKA824C1	MSKA824C2	MSKA824C3	MSXLKA824C1Y	MSXLKA824C2Y	MSXLKA824C3Y
305 mm (12 in)	MSKA1224C1	MSKA1224C2	MSKA1224C3	MSXLKA1224C1Y	MSXLKA1224C2Y	MSXLKA1224C3Y
406 mm (16 in)	MSKA1624C1	MSKA1624C2	MSKA1624C3	MSXLKA1624C1Y	MSXLKA1624C2Y	MSXLKA1624C3Y
508 mm (20 in)	MSKA2024C1	MSKA2024C2	MSKA2024C3	MSXLKA2024C1Y	MSXLKA2024C2Y	MSXLKA2024C3Y
610 mm (24 in)	MSKA2424C1	MSKA2424C2	MSKA2424C3	MSXLKA2424C1Y	MSXLKA2424C2Y	MSXLKA2424C3Y
711 mm (28 in)	MSKA2824C1	MSKA2824C2	MSKA2824C3	MSXLKA2824C1Y	MSXLKA2824C2Y	MSXLKA2824C3Y
813 mm (32 in)	MSKA3224C1	MSKA3224C2	MSKA3224C3	MSXLKA3224C1Y	MSXLKA3224C2Y	MSXLKA3224C3Y
914 mm (36 in)	MSKA3624C1	MSKA3624C2	MSKA3624C3	MSXLKA3624C1Y	MSXLKA3624C2Y	MSXLKA3624C3Y
1016 mm (40 in)	MSKA4024C1	MSKA4024C2	MSKA4024C3	MSXLKA4024C1Y	MSXLKA4024C2Y	MSXLKA4024C3Y
1118 mm (44 in)	MSKA4424C1	MSKA4424C2	MSKA4424C3	MSXLKA4424C1Y	MSXLKA4424C2Y	MSXLKA4424C3Y
1219 mm (48 in)	MSKA4824C1	MSKA4824C2	MSKA4824C3	MSXLKA4824C1Y	MSXLKA4824C2Y	MSXLKA4824C3Y

**Light Screen Kits Which Include Model MSCB-1 230V ac Control Box**

Defined Area	Black Anodized Emitters and Receivers with 9-meter (30-foot) Sensing Range (Available in Yellow Painted Finish by adding "Y" at end of model number e.g. MSKB424C1Y)			Yellow Painted Emitters and Receivers with 18-meter (60-foot) Sensing Range		
	Two - 15-ft Cables	Two - 25-ft Cables	One - 15-ft Cable & One - 25-ft Cable	Two - 15-ft Cables	Two - 25-ft Cables	One - 15-ft Cable & One - 25-ft Cable
114 mm (4.5 in)	MSKB424C1	MSKB424C2	MSKB424C3	MSXLKB424C1Y	MSXLKB424C2Y	MSXLKB424C3Y
215 mm (8.5 in)	MSKB824C1	MSKB824C2	MSKB824C3	MSXLKB824C1Y	MSXLKB824C2Y	MSXLKB824C3Y
305 mm (12 in)	MSKB1224C1	MSKB1224C2	MSKB1224C3	MSXLKB1224C1Y	MSXLKB1224C2Y	MSXLKB1224C3Y
406 mm (16 in)	MSKB1624C1	MSKB1624C2	MSKB1624C3	MSXLKB1624C1Y	MSXLKB1624C2Y	MSXLKB1624C3Y
508 mm (20 in)	MSKB2024C1	MSKB2024C2	MSKB2024C3	MSXLKB2024C1Y	MSXLKB2024C2Y	MSXLKB2024C3Y
610 mm (24 in)	MSKB2424C1	MSKB2424C2	MSKB2424C3	MSXLKB2424C1Y	MSXLKB2424C2Y	MSXLKB2424C3Y
711 mm (28 in)	MSKB2824C1	MSKB2824C2	MSKB2824C3	MSXLKB2824C1Y	MSXLKB2824C2Y	MSXLKB2824C3Y
813 mm (32 in)	MSKB3224C1	MSKB3224C2	MSKB3224C3	MSXLKB3224C1Y	MSXLKB3224C2Y	MSXLKB3224C3Y
914 mm (36 in)	MSKB3624C1	MSKB3624C2	MSKB3624C3	MSXLKB3624C1Y	MSXLKB3624C2Y	MSXLKB3624C3Y
1016 mm (40 in)	MSKB4024C1	MSKB4024C2	MSKB4024C3	MSXLKB4024C1Y	MSXLKB4024C2Y	MSXLKB4024C3Y
1118 mm (44 in)	MSKB4424C1	MSKB4424C2	MSKB4424C3	MSXLKB4424C1Y	MSXLKB4424C2Y	MSXLKB4424C3Y
1219 mm (48 in)	MSKB4824C1	MSKB4824C2	MSKB4824C3	MSXLKB4824C1Y	MSXLKB4824C2Y	MSXLKB4824C3Y

## Models & Accessories

### Light Screen Kits Which Include Model MSCT-1 24V dc Control Box

Defined Area	Black Anodized Emitters and Receivers with 9-meter (30-foot) Sensing Range (Available in Yellow Painted Finish by adding "Y" at end of model number e.g. MSKT424C1Y)			Yellow Painted Emitters and Receivers with 18-meter (60-foot) Sensing Range		
	Two - 15-ft Cables	Two - 25-ft Cables	One - 15-ft Cable & One- 25-ft Cable	Two - 15-ft Cables	Two - 25-ft Cables	One - 15-ft Cable & One- 25-ft Cable
114 mm (4.5 in)	MSKT424C1	MSKT424C2	MSKT424C3	MSXLKT424C1Y	MSXLKT424C2Y	MSXLKT424C3Y
215 mm (8.5 in)	MSKT824C1	MSKT824C2	MSKT824C3	MSXLKT824C1Y	MSXLKT824C2Y	MSXLKT824C3Y
305 mm (12 in)	MSKT1224C1	MSKT1224C2	MSKT1224C3	MSXLKT1224C1Y	MSXLKT1224C2Y	MSXLKT1224C3Y
406 mm (16 in)	MSKT1624C1	MSKT1624C2	MSKT1624C3	MSXLKT1624C1Y	MSXLKT1624C2Y	MSXLKT1624C3Y
508 mm (20 in)	MSKT2024C1	MSKT2024C2	MSKT2024C3	MSXLKT2024C1Y	MSXLKT2024C2Y	MSXLKT2024C3Y
610 mm (24 in)	MSKT2424C1	MSKT2424C2	MSKT2424C3	MSXLKT2424C1Y	MSXLKT2424C2Y	MSXLKT2424C3Y
711 mm (28 in)	MSKT2824C1	MSKT2824C2	MSKT2824C3	MSXLKT2824C1Y	MSXLKT2824C2Y	MSXLKT2824C3Y
813 mm (32 in)	MSKT3224C1	MSKT3224C2	MSKT3224C3	MSXLKT3224C1Y	MSXLKT3224C2Y	MSXLKT3224C3Y
914 mm (36 in)	MSKT3624C1	MSKT3624C2	MSKT3624C3	MSXLKT3624C1Y	MSXLKT3624C2Y	MSXLKT3624C3Y
1016 mm (40 in)	MSKT4024C1	MSKT4024C2	MSKT4024C3	MSXLKT4024C1Y	MSXLKT4024C2Y	MSXLKT4024C3Y
1118 mm (44 in)	MSKT4424C1	MSKT4424C2	MSKT4424C3	MSXLKT4424C1Y	MSXLKT4424C2Y	MSXLKT4424C3Y
1219 mm (48 in)	MSKT4824C1	MSKT4824C2	MSKT4824C3	MSXLKT4824C1Y	MSXLKT4824C2Y	MSXLKT4824C3Y

#### Pigtail Quick Disconnect Option

Any yellow emitter or receiver may be ordered with a 305 mm (12 in) cable pigtail terminated in the 5-pin male mini-style quick disconnect connector. This option accommodates requirements for right-angle exit of the cable from the base of the emitter and receiver. The same mating quick disconnect cables, as listed on page 54, are used (ordered separately). To specify a pigtail quick disconnect cable, add suffix "P" to the model number of the emitter or receiver, for example: **MSE1624YP**.



## Documentation

The following documentation is supplied with each **MINI-SCREEN** System Control Box. Additional copies are available at no charge.

**Instruction Manual for MINI-SCREEN Systems:** order p/n 39022 (this manual).

**Checkout Procedure Card (Daily):** order p/n 39020

**Checkout Procedure Card (Semi-annual):** order p/n 39021

## Replacement Parts, MINI-SCREEN Systems

40091	<b>BA2MB</b>	Mounting Hardware Kit for one emitter or receiver
27850	<b>MGA-GSA-1</b>	Ground strap, control box door
28513	<b>MGA-K-1</b>	Replacement key
30140	<b>MGA-KSO-1</b>	Key switch, only (no wires)
39029	<b>MSAB-1</b>	Microprocessor control module
39023	<b>MSA-KS-1</b>	Key switch, pre-wired
39027	<b>MSA-PSA-1</b>	Replacement power supply board (115V ac)
39028	<b>MSA-PSB-1</b>	Replacement power supply board (230V ac)
43738	<b>MSA-PST-1</b>	Replacement power supply board (24V dc)
39024	<b>MSA-MH-1</b>	Control box mounting hardware
39025	<b>MSA-RM-1</b>	Relay module
39026	<b>STP-2</b>	Specified test piece (.75" dia.)
39911	<b>STP-3</b>	Specified test piece (1.75" dia.)
48981	<b>STP-7</b>	Specified test piece (1.00" dia.)
49162	<b>STP-8</b>	Specified test piece (2.00" dia.)

## MSA Series Lens Shields

Model MSSxx is a replaceable protective cover for the lens of a MINI-SCREEN sensor. The shield is made of 1.5 mm (0.06 in) clear polycarbonate.

Shield models are available for every length of sensor from 4 inches to 48 inches (see chart, below). The shields attach to the sensor using two adhesive-backed Neoprene foam strips.

*Application Note: When shields are installed on both the emitter and receiver, excess gain is reduced by 36 percent (and maximum operating range is reduced by 20 percent).*

Protective-Shield	Model Number	Assembly Number	Length
4"	<b>MSS4</b>	44308	5.4"
8"	<b>MSS8</b>	44308	9.4"
12"	<b>MSS12</b>	44310	13.4"
16"	<b>MSS16</b>	44311	17.4"
20"	<b>MSS20</b>	44312	21.4"
24"	<b>MSS24</b>	44313	25.3"
28"	<b>MSS28</b>	44314	29.3"
32"	<b>MSS32</b>	44315	33.3"
36"	<b>MSS36</b>	44316	37.3"
40"	<b>MSS40</b>	44317	41.3"
44"	<b>MSS44</b>	44318	41.3"
48"	<b>MSS48</b>	44319	49.3"

## Accessories

### MSM Series Corner Mirrors

Mirror Model	Part Number	Reflective Area Y	Mounting L1	Height L2
MSM4A	43162	6.5 in (16.5 cm)	8.7 in (22.1 cm)	7.5 in (19.1 cm)
MSM8A	43163	10.5 in (26.7 cm)	12.7 in (32.3 cm)	11.5 in (29.2 cm)
MSM12A	43164	14 in (35.6 cm)	16.2 in (41.1 cm)	15 in (38.1 cm)
MSM16A	43165	18 in (45.7 cm)	20.2 in (51.3 cm)	19 in (48.3 cm)
MSM20A	43166	22 in (55.9 cm)	24.2 in (61.5 cm)	23 in (58.4 cm)
MSM24A	43167	26 in (66.0 cm)	28.2 in (71.6 cm)	27 in (68.6 cm)
MSM28A	43168	30 in (76.2cm)	32.2 in (81.8 cm)	31 in (78.7 cm)
MSM32A	43169	34 in (86.4 cm)	36.2 in (91.9 cm)	35 in (88.9 cm)
MSM36A	43170	38 in (96.5 cm)	40.2 in (102.1 cm)	39 in (99.1 cm)
MSM40A	43171	42 in (106.7 cm)	44.2 in (112.3 cm)	43 in (109.2 cm)
MSM44A	43172	46 in (116.8 cm)	48.2 in (122.4 cm)	47 in (119.4 cm)
MSM48A	43173	50 in (127.0 cm)	52.2 in (132.6 cm)	51 in (129.5 cm)

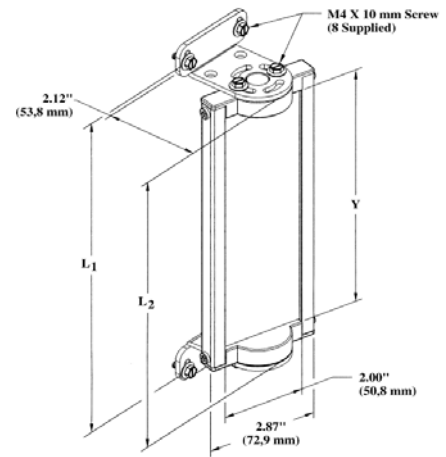

### MSA Series Stands

Model of Stand	Part Number	Stand Height	Mirror Length (Brackets Outward)	Mirror Length (Brackets Inward)
MSA-S24-1	43174	24 inches	4 to 8 inches	4 to 12 inches
MSA-S42-1	43175	42 inches	4 to 24 inches	4 to 28 inches
MSA-S66-1	43176	66 inches	4 to 48 inches	4 to 48 inches

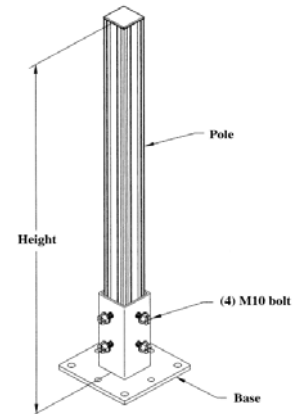

**Warranty:** Banner Engineering Corporation warrants its products to be free from defects for a period of one year. Banner Engineering Corporation will repair or replace, free of charge, any product of its manufacture found to be defective at the time it is returned to the factory during the warranty period. This warranty is necessarily limited to the quality of materials and workmanship in MINI-SCREEN Systems as they are supplied to the original purchaser. Proper installation, operation, and maintenance of the MINI-SCREEN System becomes the responsibility of the user upon receipt of the system. This warranty does not cover damage or liability for the improper application of the MINI-SCREEN System. This warranty is in lieu of any other warranty either expressed or implied.

**See also warranty-related return shipping information, page 37.**

**U.S. Federal Regulations Applicable to Use of Safety Light Curtains**

**OSHA 29 CFR 1910.212**

General Requirements for (guarding of) All Machines

**OSHA 29 CFR 1910.217**

(Guarding of) Mechanical Power Presses

Part of:

Code of Federal Regulations  
Title 29, Parts 1900 to 1910

Address:

Superintendent of Documents  
Government Printing Office  
Washington, D.C. 20402-9371  
Telephone: 202-783-3238

**Standards Applicable to Design of Safety Light Curtains**

**UL 491**

The Standard for Power-operated Machine Controls and Systems

Address:

Underwriters Laboratories Inc.  
333 Pfingsten Road  
Northbrook, IL 60062-2096  
Telephone: 708-272-8800

**BS 6491**

General Requirements for Electro-sensitive Safety Systems for Industrial Machines

Address:

British Standards Association  
2 Park Street  
London W1A 2BS  
England  
Telephone: 011-44-908-1166

**ANSI B11 Standards: Standards Applicable to Use of Safety Light Curtains**

**ANSI B11.1-1988**

Mechanical Power Presses

**ANSI B11.2-1982**

Hydraulic Power Presses

**ANSI B11.3-1982**

Power Press Brakes

**ANSI B11.4-1993**

Shears

**ANSI B11.5-1988**

Iron Workers

**ANSI B11.6-1984**

Lathes

**ANSI B11.7-1995**

Cold Headers and Cold Formers

**ANSI B11.8-1983**

Drilling, Milling, and Boring Machines

**ANSI B11.9-1975**

Grinding Machines

**ANSI B11.10-1990**

Metal Sawing Machines

**ANSI B11.11-1985**

Gear Cutting Machines

**ANSI B11.12-1983**

Roll Forming and Roll Bending Machines

**ANSI B11.13-1992**

Single- and Multiple-Spindle Automatic Bar and Chucking Machines

**ANSI B11.14-1983**

Coil Slitting Machines/Systems

**ANSI B11.15-1984**

Pipe, Tube, and Shape Bending Machines

**ANSI B11.16-1988**

Metal Powder Compacting Presses

**ANSI B11.17-1982**

Horizontal Extrusion Presses

**ANSI B11.18-1992**

Machinery and Machine Systems for the Processing of Coiled Strip, Sheet, and Plate

**ANSI B11.19-1990**

Performance Criteria for the Design, Construction, Care, and Operation of Safeguarding when Referenced by the Other B11 Machine Tool Safety Standards

**ANSI B11.20-1991**

Manufacturing Systems/Cells

**ANSI/RIA 15.06**

Safety Requirements for Industrial Robots and Robot Systems

**ANSI B11 Documents**

*American National Standards Institute  
11 West 42nd Street  
New York, NY 10036*

*-or-*

**Safety Director**

*National Machine Tool Builders Assn.  
7901 Westpark Drive  
McLean, VA 22102-4269*

**ANSI/RIA Documents**

*Obtain from ANSI (above) or:*

*Robotic Industries Association  
900 Victors Way, P.O. Box 3724  
Ann Arbor, MI 48106  
Telephone: 313-994-6088*

