



**ISO9002**  
DOCUMENTED QUALITY

# BEAM-ARRAY™

# MACHINE-GUARD System

## Instruction Manual

- An optoelectronic point-of-operation guarding device for production machinery such as hydraulic and pneumatic power presses, molding presses, and automated production equipment (see page 3)
- Creates a curtain of synchronized, modulated infrared sensing beams from 6 inches to 6 feet high (12 length increments, see page 19); system has 3x excess gain remaining at the specified maximum range of 45 feet
- FMEA tested to ensure control reliability
- Opposed mode configuration with many times the sensing power of competitive units: reliably penetrates dust, dirt, oil, fog, and mist
- Replaceable redundant output relays with "forced guided" contacts to ensure control reliability
- Features *floating blanking*, easily configured inside control box
- Controller uses "diverse redundancy" design concept to achieve a higher level of control reliability
- Highly immune to EMI, RFI, and ambient light; highly immune to strobe light
- Modular design with no "matched sets" necessary: any emitter and receiver (of equal length) and any control box may be used together
- Epoxy-encapsulated, vibration-tolerant, factory burned-in emitter and receiver circuitry for toughness and dependability
- Versatile swivel mounting brackets and small, light-weight tubular sensors for easy installation and alignment both on new equipment and in retrofit applications



Certified in compliance with  
**British Standard**  
BS6491 PARTS I & II

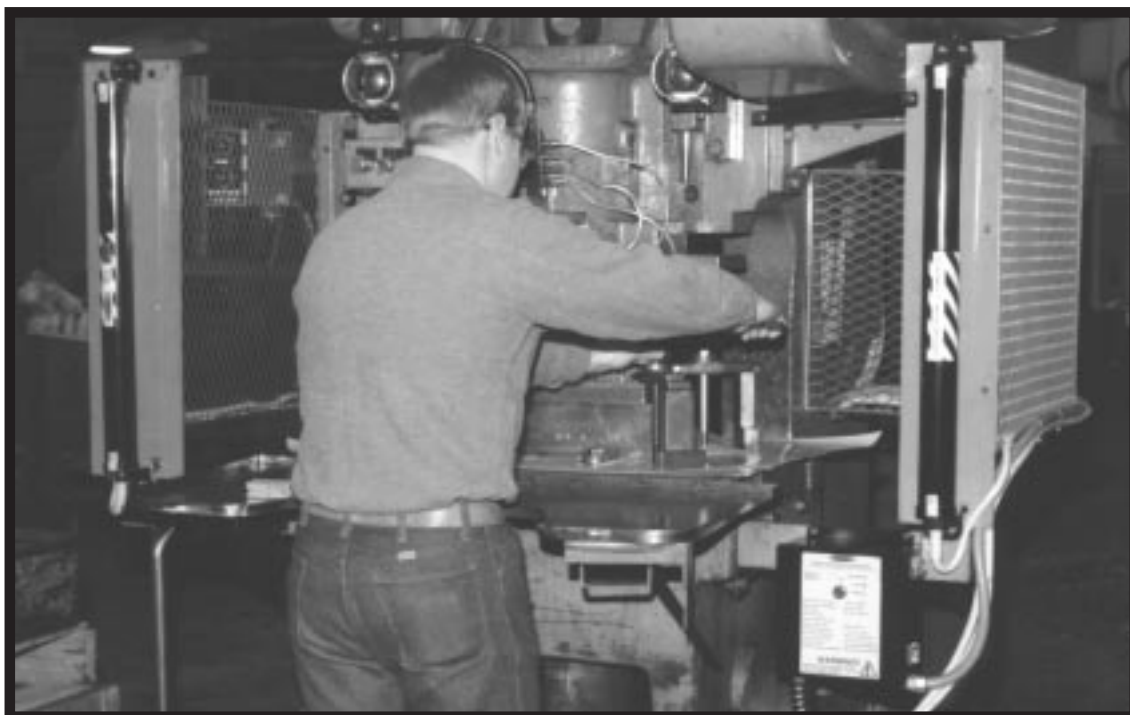

Spanish language instruction manuals and product labels are available by request. See page 35.

Los manuales de instrucciones y las etiquetas de los productos están disponibles en español si usted lo pide. Ver la pagina 35.

**Banner MACHINE-GUARD Systems are designed and built in the U.S.A.**

# Important... read this page first!



In the United States, the *functions* that the Banner BEAM-ARRAY™ MACHINE-GUARD System is intended to perform are regulated by the Occupational Safety and Health Administration (OSHA). However, whether or not any particular MACHINE-GUARD System *installation* meets all applicable OSHA requirements depends upon factors that are beyond the control of Banner Engineering Corporation. These factors include the details of how the MACHINE-GUARD System is applied, installed, wired, operated, and maintained.

Banner Engineering Corp. has made every effort to provide complete application, installation, operation, and maintenance instructions. In addition, we suggest that any questions regarding application or use of the MACHINE-GUARD System be directed to the factory applications department at the telephone numbers or address shown at the bottom of this page.

Banner MACHINE-GUARD Systems can guard against accidents *only* when they are properly installed and integrated into the machine, properly operated, and properly maintained. See Section 3 of this manual for installation procedures, considerations, and precautions. See Sections 4 and 5 for operating and maintenance information. It is the responsibility of the purchaser and/or user to apply this MACHINE-GUARD System in full compliance with OSHA regulations.

The user of the MACHINE-GUARD System shall ensure that all machine operators, maintenance personnel, electricians, and supervisors are thoroughly familiar with and understand all instructions regarding the use and maintenance of the MACHINE-GUARD System and the machinery upon which it is installed, as well as all appropriate safety regulations.

In addition to OSHA regulations, several other organizations provide informational material on the use of machine guard devices (see information box, below right). The user is referred to ANSI B11, the Robotics Institute of America (RIA), the American Metal Stamping Association (AMSA), and others. Banner Engineering Corp. makes no claim regarding a specific recommendation of any organization, the accuracy or effectiveness of any information provided, or the appropriateness of the provided information for a specific application.

The user has the responsibility to ensure that all local, state, and national laws, rules, codes, and regulations relating to the use of this machine guarding system in any particular application are satisfied. Extreme care is urged to ensure that all legal requirements have been met and that all installation and maintenance instructions contained in this manual are followed.

## Caution!!

Banner BEAM-ARRAY™ MACHINE-GUARD Systems are for use only on machinery that can be stopped immediately after a stop signal is issued. They may be used with part-revolution clutched machines that have the ability to stop at any point in their stroke. *Under no circumstances may the BEAM-ARRAY MACHINE-GUARD System be used on full-revolution clutched machinery. Banner MACHINE-GUARD Systems may not be used as tripping devices to initiate machine motion in PSDI (Presence Sensing Device Initiation) applications on mechanical power presses, per OSHA regulation 29 CFR 1910.217.*

<b>U.S. Standards Applicable to Use of MACHINE-GUARD™ Systems</b>	
<b>ANSI B11.19</b>	<b>Safeguarding of Machine Tools</b>
<b>ANSI/RIA 15.06</b>	<b>Safety Requirements for Robot Systems</b>
Copies are available from: Safety Director National Machine Tool Builders Association 7901 Westpark Drive McLean, VA 22101-4269	
See page 32 for a detailed listing of applicable standards and requirements	

## *Applications and Limitations of MACHINE-GUARD Systems*

### **MACHINE-GUARD Systems are typically used in the following applications:**

#### **Hydraulic and pneumatic power presses**

Punch presses (stamping, blanking, piercing)  
Press brakes  
Drawing presses  
Forming presses  
Forming rolls  
Shears

#### **Molding presses**

Thermoplastic  
Thermoset  
Die casting  
Powdered metal

#### **Automated production equipment**

Machining centers  
Saws  
Powered assembly equipment  
Automatic welding stations  
Packaging machinery  
Palletizers  
Robotic assembly stations  
Extruders  
Slitters  
Riveters

### **MACHINE-GUARD Systems may NOT be used with the following machinery:**

Any machine that cannot be stopped immediately after a stop signal is issued, such as single stroke (also known as "full-revolution") clutched machinery.

Any machine with inadequate or inconsistent machine response time and stopping performance.

Any machine that ejects materials or component parts through the defined area.

MACHINE-GUARD Systems may not be used in any environment that is likely to adversely affect the efficiency of a photoelectric sensing system. For example, corrosive chemicals or fluids or unusually severe levels of smoke or dust, if not controlled, may degrade the efficiency of Banner MACHINE-GUARD Systems.

*Banner MACHINE-GUARD Systems may not be used as tripping devices to initiate machine motion (PSDI applications) on mechanical power presses, per OSHA regulation 29 CFR 1910.217.*

## **Table of Contents**

Warnings and Important Information .....	page 2
Applications & Limitations Notices, Banner MACHINE-GUARD Systems .....	page 3
<b>1. MACHINE-GUARD System Introduction .....</b>	<b>page 4</b>
<b>2. Overview of Operation .....</b>	<b>page 5</b>
2.1 Output Relay Operation .....	page 5
2.2 Floating Blanking .....	page 6
2.3 Lockout Conditions and Key Resets .....	page 7
2.4 Operating Status Indicator Lights .....	page 7
2.5 Control Reliability:	
Redundancy & Self-checking .....	page 7
2.6 Diagnostic Indicator LEDs .....	page 9
<b>3. System Installation and Alignment .....</b>	<b>page 9</b>
3.1 Appropriate Applications .....	page 9
3.2 Mechanical Installation Considerations .....	page 9
3.2.1 Separation Distance .....	page 9
3.2.2 Hard Guarding .....	page 10
3.3 Mounting Procedure .....	page 11
3.4 Control Module Configuration .....	page 12
3.5 Electrical Hookup .....	page 13
3.5.1 Emitter and Receiver .....	page 13
3.5.2 AC Power (temporary) .....	page 13
3.5.3 M-G System Initial Checkout .....	page 15
3.5.4 Output Relay Connection .....	page 16
3.5.5 AC Power (permanent) .....	page 20
3.5.6 Auxiliary Monitor Relay .....	page 20
3.5.7 Accessory Connections .....	page 20
3.6 Control Box Latch Adjustment .....	page 20
<b>4. Operating Instructions .....</b>	<b>page 20</b>
4.1 Security Protocol .....	page 20
4.2 Periodic Checkout Requirements .....	page 21
4.3 Normal Operation .....	page 21
4.3.1 Power-up .....	page 21
4.3.2 Floating Blanking .....	page 22
<b>5. Troubleshooting and Maintenance .....</b>	<b>page 22</b>
5.1 Troubleshooting Lockout Conditions .....	page 22
5.2 Effects of Electrical and Optical Noise .....	page 23
5.3 Servicing and Maintenance .....	page 24
5.3.1 Fuse Testing and Replacement .....	page 24
5.3.2 Relay Replacement .....	page 24
5.3.3 Emitter and Receiver Alignment .....	page 24
5.3.4 Cleaning .....	page 24
<b>6. Alignment and Checkout Procedures .....</b>	<b>page 25</b>
6.1 Alignment with Corner Mirrors .....	page 25
6.2 Commissioning Checkout .....	page 28
6.3 Shift Change & Machine Setup Change .....	page 29
6.4 Semi-annual Checkout .....	page 29
(Initial Checkout: MACHINE-GUARD only .....	page 14)
<b>Glossary of Terms .....</b>	<b>page 30</b>
<b>Specifications, Accessories, Replacement Parts ...</b>	<b>page 33</b>
Specifications .....	page 33
Available Models .....	page 33
Replacement Parts .....	pp 34-35
Quick-Disconnect Cable Information .....	page 34
<b>System Dimension Drawing .....</b>	<b>page 18</b>

# 1. MACHINE-GUARD System Introduction

The Banner MACHINE-GUARD System is a microprocessor-controlled opposed mode optoelectronic "curtain of light". It is designed for use as a point-of-operation guarding device on production machinery.

Banner's microprocessor-based circuit establishes a higher level of control reliability in machine guard design. The MACHINE-GUARD System uses the design concept of "diverse redundancy", in which two microprocessors of different design, running from different instruction sets, constantly check all system components, including each other. MACHINE-GUARD Systems are extensively FMEA (Failure Mode and Effects Analysis) tested to establish an extremely high degree of confidence that no system component will ever, even if it does fail, cause a *failure to danger*.

In typical operation, if any part of an operator's body (or any opaque object) of more than 1.50 inch in cross section enters the guarded area of the machine, the MACHINE-GUARD's output relays will open. The contacts of the output relays are connected to the guarded machine's primary control elements (MPCEs) which immediately stop the motion of the guarded machine.

The output relays have forced-guided contacts for enhanced control reliability.

Using the *floating blanking* feature, one sensing beam of the curtain may be blanked (made "blind") to allow for the movement of a workpiece of up to one inch in cross section through the curtain at any point

The Banner MACHINE-GUARD is a modular machine guard system. Each system is made up of an MGE Series emitter unit, an MGR Series receiver unit, and a model MGCA-5A or MGCB-5A control box (see Figure 1 and cover photo). Emitter units consist of a row of synchronized modulated infrared (invisible) light emitting diodes (LEDs) in a tubular metal housing. Receiver units consist of a corresponding row of synchronized phototransistors in a tubular metal housing. Emitters and receivers are available in a range of sizes (based on the height of the defined area), in 12 models ranging in length from 6 inches to 6 feet. The tubular sensor design includes a swivel bracket at each end for quick mounting and easy alignment. A listing of available models is given on page 33. Optional corner mirrors enable a single emitter/receiver pair to

**Figure 1. Banner MACHINE-GUARD System: emitter, receiver, control box, and QD-style interconnecting cable (cable is purchased separately)**

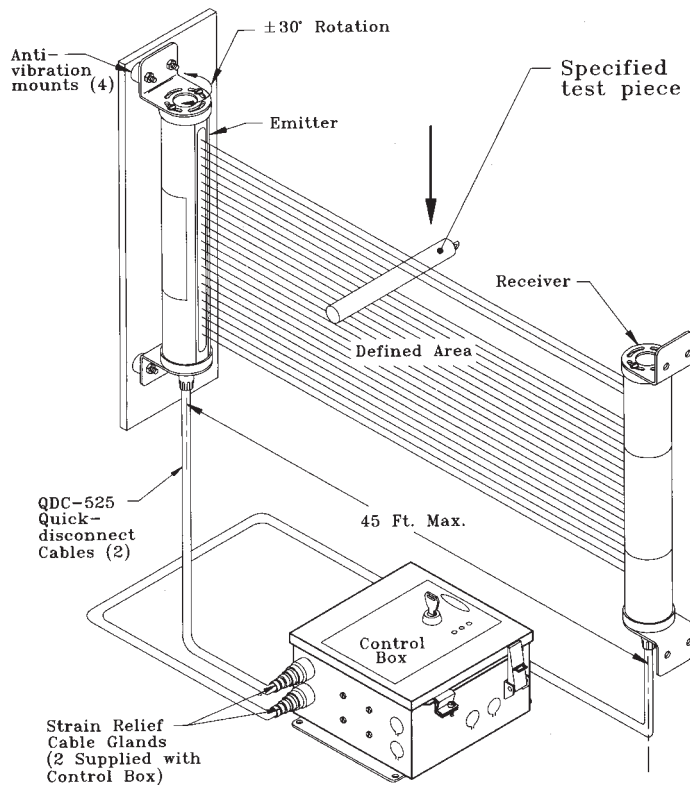

**WARNING** The MACHINE-GUARD System uses **one pair** of sensors connected to **one** control box. Connection of multiple pairs of sensors to a single control box can result in a dangerous situation, and is prohibited.

*MACHINE-GUARD Systems support the use of corner mirrors, which enable sensing along more than one side of an area using only one emitter and one receiver. See page 33.*

---

guard more than one side of an area (see Section 6.1).

The control box contains a power supply (to power the control box itself along with an emitter and receiver), a plug-in microprocessor controller module to control sensing logic, and a relay board which holds replaceable output relays. Three panel-mounted LEDs indicate the operating status of the system. Diagnostic LEDs located on the controller module identify seven different trouble causes. There is a keyed panel switch for resetting the system from fault (lock-out) conditions. The three MACHINE-GUARD System units are interconnected using two 5-wire cables with QD (Quick Disconnect) cable connectors on their emitter and receiver ends.

Banner Engineering Corp. is the photoelectric industry leader in the design of high-power modulated infrared presence sensors. The MACHINE-GUARD System is conservatively rated at a sensing range of 45 feet, at which point there remains a reserve of optical sensing energy\*. MACHINE-GUARD Systems produce many times the optical sensing power of competitive units to reliably penetrate the dust, dirt, oil, fog, and mist that are often present in industrial applications. The patented modulated receiver design produces exceptionally high immunity to ambient light interference.

## 2. Overview of MACHINE-GUARD System Operation

In operation, an emitter and receiver (of equal length) are mounted and aligned opposite each other at a separation distance of from 6 inches to 45 feet (14 meters)\*. This establishes a curtain of invisible infrared light beams called the *defined area* (Figure 1). Center-to-center spacing between adjacent sensing beams is .75 inch.

The following features of the MACHINE-GUARD System are discussed in the listed sections:

- Output Relay Operation (Section 2.1)
- Floating Blanking (Section 2.2)
- Lockout Conditions and Key Resets (Section 2.3)
- Operating Status Indicator Lights (Section 2.4)
- Control Reliability: Redundancy & Self-checking (Section 2.5)
- Diagnostic Indicator LEDs (Section 2.6)

### 2.1 Output Relay Operation

The MACHINE-GUARD System control box has three output relays plus an Auxiliary Monitor Relay. Refer to Figure 2 (page 6). The three output relays are labeled "FSD1", "FSD2", and "SSD". The contacts of the Final Switching Device (FSD) relays (FSD1 and FSD2) are connected to the Machine Primary Control Elements (MPCEs) of the guarded machine. An MPCE is an electrically powered element of the guarded machine that directly controls the machine's

Banner MACHINE-GUARD Systems are designed for convenient and dependable operation in difficult industrial environments. The microprocessor controller module has UL recognized conformal coating and a plug-in design for easy configuring or replacement. Output relays are easily replaceable. The control box enclosure is rated NEMA 13 (IP 64) and features a lockable latch.

Emitter and receiver circuits are epoxy-encapsulated to meet high standards for vibration resistance. Every MACHINE-GUARD System emitter, receiver, and controller module is serialized and undergoes extensive burn-in testing at the factory.

Any MACHINE-GUARD System emitter and receiver (of equal length) may be used together with the appropriate model control box. Unlike some competitive systems, factory-matched sets are *not* required.

A functional schematic diagram of the MACHINE-GUARD System appears on the next page. For a MACHINE-GUARD System dimension drawing, see pages 18 and 19. For specifications, see page 33.

*\* The MACHINE-GUARD System has 3X excess gain remaining at an emitter-receiver separation distance of 45 feet.*

normal operating motion in such a way that it is last (in time) to operate when motion is either initiated or arrested. The Secondary Switching Device (SSD) relay contacts are connected to the guarded machine's Machine Secondary Control Element (MSCE), an electrically powered element of the guarded machine (independent of both MPCEs) that is capable of removing power from the prime mover of the dangerous part of the machine in the event of a system fault. The two MPCEs must each (alone) be capable of stopping the motion of the guarded machine in an emergency. The opening of any output relay contact results in the removal of power to either an MPCE or MSCE (or both), which will stop the motion in the guarded machine.

Any object that blocks one or more *unblanked* beams will be detected, and will cause a *trip condition*: output relays FSD1 and FSD2 (but not SSD) in the control box open their contacts. *All three* output relays (FSD1, FSD2, and SSD) will open their contacts in response to any one or more of six *lockout conditions*, including component failure within the MACHINE-GUARD System itself (see Section 2.5). The MACHINE-GUARD System automatically resets itself from a *trip condition* when the object that caused the trip is removed, but recovery from a *lockout condition* requires a *key reset* (Section 2.3).

**Figure 2. Banner MACHINE-GUARD System Functional Schematic**

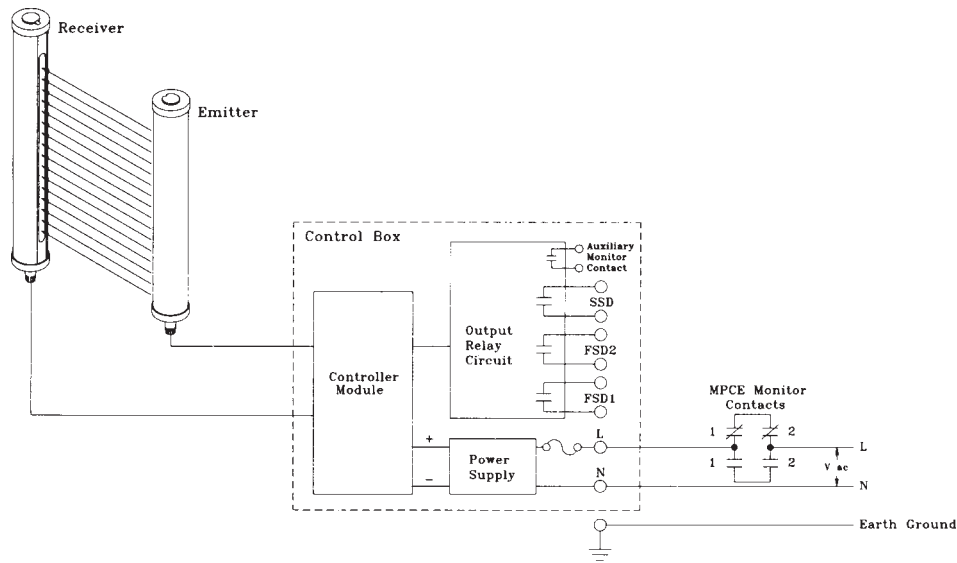

The Auxiliary Monitor Relay is a separate relay that follows the action of output relays FSD1 and FSD2. It is intended for non safety-related purposes, and is typically used to signal a programmable logic controller (PLC) when output relay contacts FSD1 and FSD2 open or close.

## 2.2 Floating Blanking

MACHINE-GUARD Systems may be configured to be "blind" to the *passage* through the defined area of an object of limited size. This feature is called *floating blanking*.\*

*Floating blanking* (Figure 3A) is the "blinding" of one sensing beam, which will appear to change position ("float") in order to allow an object (usually workpiece material of less than 1 inch in cross section) to move through the defined area, *at any point*, without tripping the final switching device (FSD relays) of the MACHINE-GUARD System. Use of floating blanking changes the *minimum object sensitivity* of the system (discussed in Sec. 3.2). A typical application of floating blanking is metal forming in a press brake (Figure 3B).

Floating blanking parameters are set (configured) at a row of DIP switches on the controller module inside the control box (see Section 3.4 and Figure 10, page 14, for details). The control box is supplied with a lockable latch to prevent unauthorized access to blanking settings.

## 2.3 Lockout Conditions and Key Resets

A *lockout condition* of the MACHINE-GUARD System causes *all* of its output relays to open, sending a "stop" signal to the guarded machine. A lockout condition will occur:

**Figure 3A. Floating Blanking Concept**

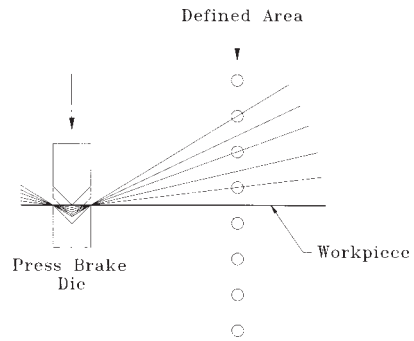

**Figure 3B. Floating Blanking in Press Brake Application**

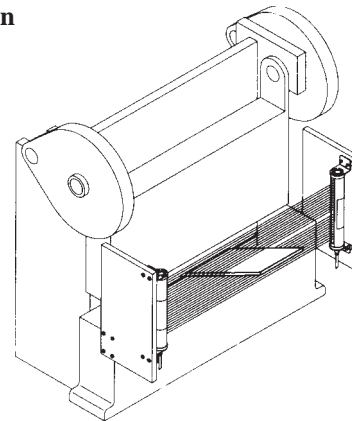

\*Floating blanking "on" is indicated by a *flashing* green front panel Operating Status Indicator LED.

- 1) Upon "power-up" of the MACHINE-GUARD System,
- 2) If ac power to the MACHINE-GUARD System is interrupted,
- 3) If only one FSD (Final Switching Device) relay has gone to the "off" state (de-energized),
- 4) If the SSD (Secondary Switching Device) relay has de-energized,
- 5) If the controller module internal switch settings are inconsistent with each other or incorrect for the emitter/receiver array length in use, or
- 6) If the self-checking circuits of the microprocessor detect a component failure.

The existence of a lockout condition is indicated by the flashing red LED on the control box panel. Green and yellow LEDs will be "off". See Figure 4, and also Figure 5 (page 8). Diagnostic Indicator LEDs (located inside the control box on the controller module) will indicate the cause of the lockout (Section 2.6).

Some lockout conditions result from component failures, which must be corrected before the system will allow operation to continue (Section 2.5). Whatever the cause, lockout conditions always require a RESET of the keyed switch on the control box cover (a *key reset*) to return the system to the RUN mode (explained in Section 2.4). A valid *key reset* consists of turning the key switch to the RESET position for at least 1/2 second, and then returning the key switch to the RUN position.

## 2.4 Operating Status Indicator lights

The control box panel has three Operating Status Indicator LEDs (see Figures 4 and 5): green (CLEAR), red (BLOCKED), and yellow (RESET). Their indications are as follows:

**RED (only) "on" and flashing:** a lockout condition due to an internal MACHINE-GUARD System problem exists. SSD, FSD1, FSD2, and Auxiliary Monitor contacts are all open (de-energized).

**YELLOW (only) "on" and flashing:** a power-up or power interrupt lockout condition exists. *These lockouts occur in the normal course of powering up the System or after an interruption of power to the System.* SSD, FSD1, FSD2, and Auxiliary Monitor contacts are open (de-energized).

**YELLOW (only) "on"steadily:** key switch is in the RESET position. FSD1, FSD2, and Auxiliary Monitor contacts open (de-energized). SSD contacts are closed (energized).

**RED and YELLOW "on" steadily (blocked condition):** the MACHINE-GUARD System has been reset and is in the RUN mode, but either there is an obstruction in the defined area or the emitter and receiver are misaligned. FSD1, FSD2, and Auxiliary Monitor contacts are open (de-energized). SSD relay is closed (energized). If alignment is correct, the GREEN\* light

**Figure 4. A MACHINE-GUARD System Control Box. The system described in this manual uses model MGCA-5A or MGCB-5A.**



will come "on" (to join YELLOW), and the RED light will go "off" when the obstruction is removed. If alignment is not correct, the GREEN light will remain "off" when the obstruction is removed. NOTE: The GREEN light is used to align the system (Section 5.2.3).

**GREEN\* and YELLOW "on" steadily:** the MACHINE-GUARD System has been reset and is in the RUN mode, the defined area is clear of obstructions, and the emitter and receiver are aligned. All output relays are closed.

**All three Status Indicator LEDs flashing:** the key reset switch has been turned to the RESET position while the MACHINE-GUARD System was operating normally. To resume operation, turn the key reset switch to RUN, then to RESET, and then back to the RUN position.

\*The GREEN LED *flashes* if blanking is "on".

## 2.5 Control Reliability: Redundancy & Self-checking

MACHINE-GUARD Systems meet certain U.S. and international *control reliability* standards for safety.

MACHINE-GUARD Systems must reliably send a "stop" signal to a guarded machine as follows:

- 1) The MACHINE-GUARD System must provide a "stop" signal to the guarded machine, within 40 or 55 milliseconds (see Specifications, page 33), whenever the defined area is interrupted, and
- 2) The MACHINE-GUARD System must provide a "stop" signal to the guarded machine when internal component failures have occurred which compromise the integrity of the MACHINE-GUARD System itself.

**Regarding the first situation:** In order for the machinery guarded by the MACHINE-GUARD System to be stopped as described, *the guarded machine must be capable of stopping at any point in its machine cycle.* This means that the MACHINE-GUARD System cannot be used with certain types of machinery (see listing, page 3). If there is any doubt about whether or not your machinery is compatible, contact the Banner Factory Application Engineers.

**Regarding the second situation:** This type of component failure includes any internal MACHINE-GUARD System failure which could prevent or delay the output relays of the MACHINE-GUARD System from going to a *trip condition* or a *lockout condition* in response to a situation which, in normal operation, would cause them to do so. The ability of the MACHINE-GUARD System to send a "stop" signal even when such a component failure has occurred depends upon the design principle of *redundancy*.

*Redundancy* requires that MACHINE-GUARD System circuit components be "backed up" to the extent that, if the failure of any single component will prevent effective stopping action when needed, that component must have a redundant counterpart which will perform the same function.

The microprocessor-controlled MACHINE-GUARD System is designed with *diverse redundancy*. Diverse redundant components are of different designs, and microprocessor programs used by them run from different instruction sets written by different programmers.

Redundancy must be maintained for as long as the MACHINE-GUARD System is in operation. Since a redundant system is no longer redundant once a component has failed, MACHINE-GUARD Systems are designed to be continuously *self-checking* (see Sections 2.6 and 5.1). A component failure detected by or within the self-checking system causes a "stop" signal to be sent to the guarded machine *and* puts the MACHINE-GUARD System into a *lockout condition*. Recovery from this type of lockout condition requires replacement of the failed component (to restore redundancy) and a *key reset*. Possible causes of lockout conditions are listed in Section 2.3. The MACHINE-GUARD System's Diagnostic Indicator LEDs (Figure 15, page 23) are used to diagnose internal causes of a lockout condition (Section 5.1).

## 2.6 Diagnostic Indicator LEDs

There are four Diagnostic Indicator LEDs located on the edge of the controller module assembly. Refer to Figure 8 (page 12) and Figure 15 (page 23). The function of these

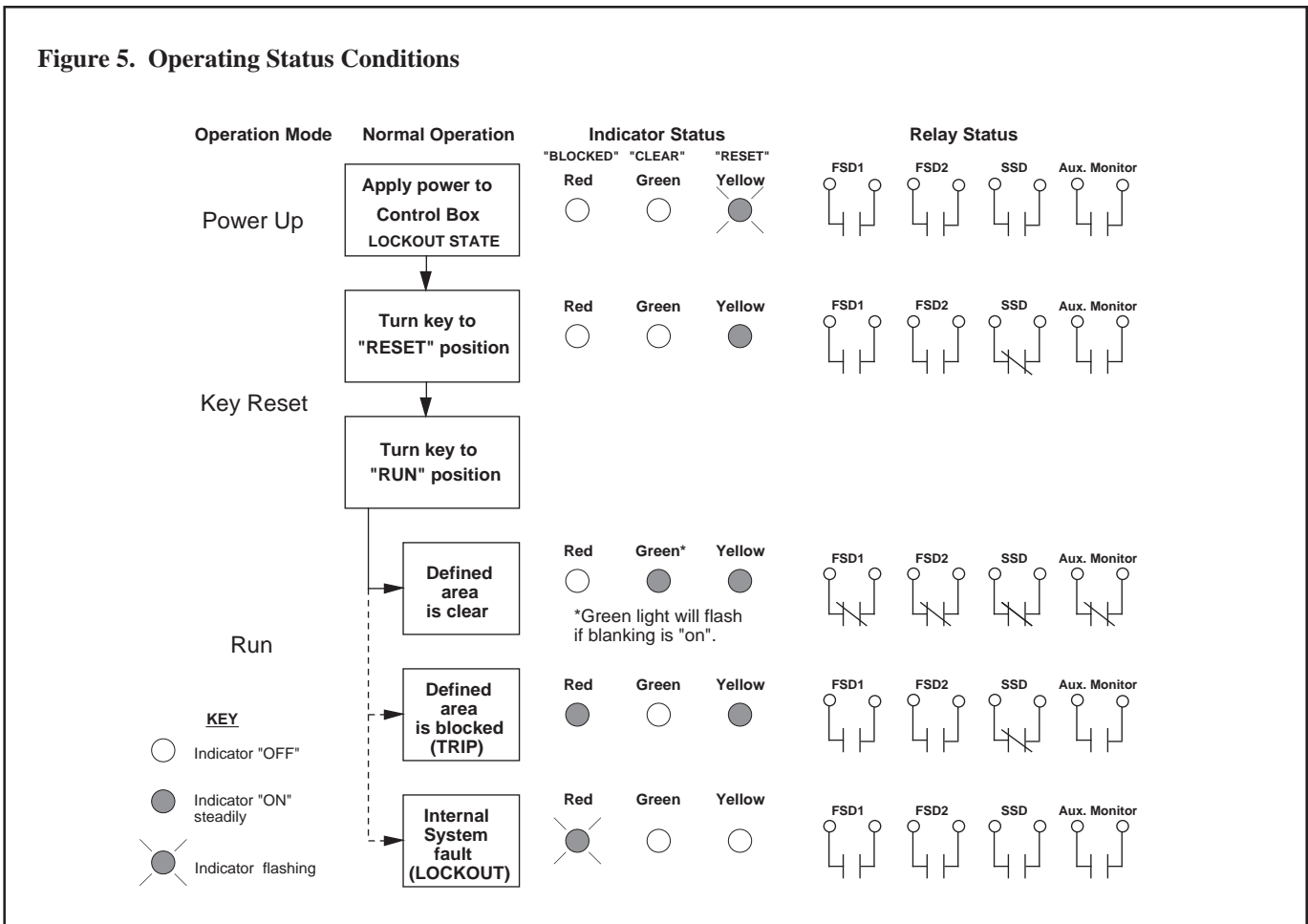



LEDs is to indicate the causes of internal MACHINE-GUARD System problems (lockouts) that are discovered as a result of the controller's self-checking function.

The green diagnostic LED is always "on", as long as power is applied to the controller, *except* when a controller micro-processor has failed. The message of the four Diagnostic Indicator LEDs is interpreted using the table in Figure 15 (page 23).

## 3. System Installation & Alignment

### 3.1 Appropriate Application

The MACHINE-GUARD System may only be used to guard machinery that is *capable of stopping motion immediately* upon receiving a stop signal and at any point in its machine cycle.

The MACHINE-GUARD System may *not* be used with single stroke (also called "full revolution") clutched machinery, as this type of machinery is incapable of stopping immediately.

Banner MACHINE-GUARD Systems may also not be used on certain other types of machinery. See page 3 for application limitations.

MACHINE-GUARDS *may not* be used as tripping devices to initiate machine motion (PSDI applications) on mechanical power presses, per OSHA regulation 29 CFR 1910.217.

### 3.2 Mechanical Installation Considerations

The two factors that influence the layout of the MACHINE-GUARD System's mechanical installation the most are:



## WARNING

Banner MACHINE-GUARD System emitters and receivers must be mounted at a distance from moving machine parts that is determined by OSHA standards found in Section 1910.217 (c)(3)(iii)(e). Failure to accurately calculate the required separation distance exactly as described in Section 3.2 of the MACHINE-GUARD manual could lead to serious injury or death.

*separation distance*, and  
*hard guarding*.

#### 3.2.1 Separation Distance

The MACHINE-GUARD System must be able to react fast enough, when a hand or other object is inserted into the defined area, to send a stop signal to the guarded machine before the object or hand reaches the closest reachable danger point on the machine. The *separation distance* is the minimum distance that is required between the midpoint of the defined area and the closest reachable danger point. The actual separation distance required depends upon several factors, including the *speed of the hand (or object)*, the *total system stopping time* (of which there are several response time components), and the *penetration depth factor*.

The formula used to calculate the separation distance is:

$$D_s = K \times (T_s + T_r) + D_{pf}$$



## WARNING

The Banner MACHINE-GUARD System is a point-of-operation machine guarding device. Its ability to perform this function depends upon the appropriateness of the application and upon the MACHINE-GUARD System's proper mechanical and electrical installation and interfacing to the machine to be guarded. If all mounting, installation, interfacing, and checkout procedures are not followed properly, the MACHINE-GUARD System cannot provide the protection for which it was designed. The user has the responsibility to ensure that all local, state, and national laws, rules, codes, or regulations relating to the installation and use of this control system in any particular application are satisfied. Extreme care should be taken to ensure that all legal requirements have been met and that all technical installation and maintenance instructions contained in this manual are followed. ***Read Section 3 of this manual carefully before installing the system. Failure to follow the instructions in Section 3 (and its subsections) could result in a dangerous situation and possible injury.***

The user has the sole responsibility to ensure that the Banner MACHINE-GUARD System is installed and interfaced to the guarded machine by **qualified persons** in accordance with this manual and applicable safety regulations. A "qualified person" is defined as "a person or persons who, by possession of a recognized degree or certificate of professional training, or who, by extensive knowledge, training, and experience, has successfully demonstrated the ability to solve problems relating to the subject matter and work" (reference ANSI/ASME B30.2-1983).

$$D_s = K \times (T_s + T_r) + D_{pf}$$

where:

- $D_s$  = the separation distance;
- $K$  = the OSHA-recommended hand speed constant of 63 inches per second (see NOTE 1, below);
- $T_s$  = the overall stop time of the machine measured from the application of the "stop" signal to the final ceasing of all motion (including stop times of all relevant control elements, and measured at maximum machine velocity). See WARNINGS (pages 9 & 10), and NOTICE regarding MPCEs (page 16)
- $T_r$  = the response time of the MACHINE-GUARD System, .040 seconds (40 milliseconds) or .055 seconds (55 milliseconds), see Specifications;
- $D_{pf}$  = the added distance due to penetration depth factor, as recommended in the table, page 11. Minimum object sensitivity is 1.50". If floating blanking is used, the penetration depth factor must be adjusted as shown in the table, page 11 (see NOTE 3, below).

**NOTES:**

- 1) The OSHA-recommended hand-speed constant (K) has been determined by various studies, and although these studies indicate speeds of 63 in/sec to over 100 in/sec, they are not conclusive determinations. The employer should consider all factors, including the physical ability of the operator, when determining the value of K to be used.
- 2)  $T_s$  is usually measured by a stop-time measuring device. If the specified machine stop time is used, we recommend that 20% be added as a safety factor to account for clutch/brake system deterioration.
- 3) Use of floating blanking will always cause the required  $D_s$  to increase (same as one channel blanked).

**3.2.2 Hard Guarding**

ANSI B11.1-1988, E6.3.2 (14) requires that "all areas of entry to the point of operation not protected by the presence-sensing device shall be otherwise safeguarded". Compliance with this requirement is discussed in the WARNING, below.



**WARNING**

The point of operation must be accessible *only* through the defined area. Mechanical barriers (screens, bars, etc.), or supplemental presence sensing devices (*supplemental guarding*) must be installed, wherever needed, to prevent any person from reaching around, under, or over the defined area and into the point of operation, and also to prevent any person from entering the space between the defined area and the point of operation. (See OSHA 1910.212). This includes the "dead beam" area of exact-blanked beams shown in Figure 6. The use of mechanical barriers for this purpose is called "hard guarding". There must be no gaps between the hard guarding and the edges of the defined area. Openings in the hard guard material must meet OSHA criteria (see OSHA 1910.217, Table O-10).

Supplemental presence sensing devices, such as safety mats, must be used if the space between the defined area and the nearest danger point is large enough to allow a person to stand undetected by the MACHINE-GUARD System.



**CAUTION**

In order for the machinery guarded by the MACHINE-GUARD System to be stopped as described, *that machinery must be capable of stopping at any point in its machine cycle.* This means that the MACHINE-GUARD System cannot be used with certain types of machinery (see listing, page 3). **If there is any doubt about whether or not your machinery is compatible with the MACHINE-GUARD System, contact the Banner Application Engineers at the factory.**



**WARNING**

The measurement of stop time ( $T_s$ ) must include the response time of *all* devices or controls that react to stop the machine. If all devices are not included, the calculated safety distance ( $D_s$ ) will be too short. This can lead to serious injury or death. *Be sure to include the stop time of all relevant devices and controls in your calculations.*

**Example:  
Separation Distance ( $D_s$ ) Calculation**

The following is an example showing how to use the formula from page 10 (above) to calculate the safety distance ( $D_s$ ).

We will use these numbers for the variables in the formula:

- $K$  = 63 inches per second (the hand speed constant set by OSHA)
- $T_s$  = .250 second (the total stop time of the example machine, specified by machine manufacturer)
- $T_r$  = .040 or .055 second (the specified response time of the MACHINE-GUARD System; see page 30)

Our example uses floating blanking (1 beam); therefore, we use a  $D_{pf}$  of 7 inches, from the table on page 11. Substitute the numbers into the formula as follows:

$$D_s = K \times (T_s + T_r) + D_{pf}$$

$$D_s = 63 \times (.250 \times 1.2^* + .040) + 7 = 28 \text{ inches}$$

Therefore, in this example, the MACHINE-GUARD emitter and receiver must be mounted such that no part of the defined area will be closer than 28 inches to the closest reachable danger point on the guarded machine.

*\*20% safety factor (see NOTE 2 at left)*

**Figure 6. Hard Guarding Requirements**

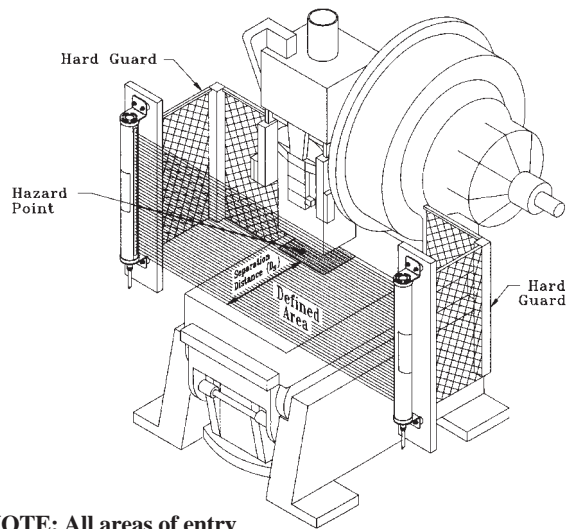

**NOTE: All areas of entry to the point of operation not protected by the MACHINE-GUARD System must be otherwise safeguarded. Refer to Section 3.2.2.**

Penetration Factor (Dpf) per ANSI B11.1 and OSHA 1910.217  
 $Dpf = 3.4 (S - .276)$  inches      S = Minimum object sensitivity

Number of Blanked Channels	Minimum Object Sensitivity	Penetration Depth Factor (Dpf)
No Blanking	1.5"	4"
1 Blanked Channel	2.3"	7"

### 3.3 Mounting Procedure

Unlike many competitive products, Banner MACHINE-GUARD System emitters and receivers are small and lightweight and easy to handle during mounting.

Also, because the curtain of light that is produced by the MACHINE-GUARD System is more powerful than those produced by competitive units, alignment is easier, and can usually be accomplished simply by mounting the emitter and receiver directly opposite each other (via corner mirrors, if used). The mounting brackets (supplied) allow  $\pm 30$  degrees rotation for quick, easy alignment. For maximum convenience, use Banner MGA Series Stand Poles (product data sheet P/N 29883). NOTE: The use of corner mirrors somewhat reduces the maximum specified emitter/receiver separation distance of 45 feet. We recommend liberal use of hard guarding to keep mirrors to a necessary minimum.

Figure 13 (pages 18-19) gives bracket dimension details and dimensions for the mounting hole pattern of the emitter and receiver with mounting brackets attached. The dimensions given assume that the mounting brackets are installed as shown, with their flanges facing *away* from the ends of the sensors. Alternatively, one or both of the mounting brackets may be installed in the opposite orientation (bracket flange pointed "inward") to conserve mounting area. If this is done, however, the mounting "footprint" will change.

**Figure 7. Emitter and Receiver Mounting**  
 (see also Figure 13, pages 18-19)

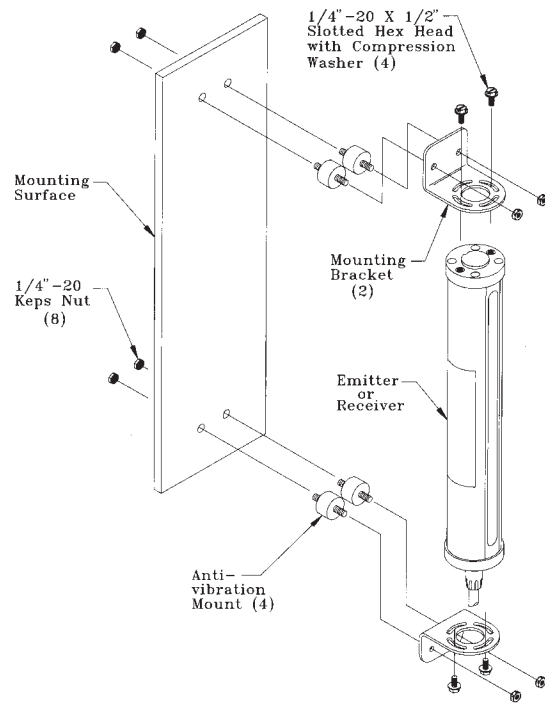

## CAUTION

It may be possible for a highly reflective surface (such as a shiny machine surface or a shiny workpiece) to reflect sensing light around an object in the defined area, thus preventing that object from being detected. This potentially dangerous condition is discovered using the "trip test" as described in the Initial Checkout Procedure (Section 3.5.3), the Alignment Procedure (Section 6.1), and the periodic checkout procedures (Sections 6.2, 6.3, and 6.4).

When this condition is discovered, take measures to eliminate the problem reflection(s). If possible, relocate the sensors to move the defined area away from the reflective surface(s). If relocating the sensors, be careful to retain at least the required separation distance (Section 3.2.1). Otherwise, paint, mask, or roughen the interfering shiny surface to reduce its reflectivity. Use the trip test to verify that these changes have eliminated the problem reflection(s).

NOTE: If the workpiece is especially reflective and comes close to the defined area, perform the trip test with the shiny workpiece in place.

From a common point of reference, make measurements to locate the emitter and receiver in the same plane with their midpoints directly opposite each other. **Important: The connector ends of both sensors must point in the same direction (see drawing and WARNING, page 18).** Mount the emitter and receiver brackets using the vibration isolators and 1/4"-20 Keps nuts (all supplied). See Figure 7. Standard 1/4" bolts may be substituted where the emitter and receiver are not subjected to shock or vibration forces. While the internal circuits of the emitter and receiver are able to withstand heavy impulse forces, the vibration isolators dampen impulse forces and prevent possible damage due to resonant vibration of the emitter or receiver assembly.

Mount the emitter and receiver in their brackets and position the red lenses of the two units directly facing each other (via corner mirrors, if used\*). Measure from one or more reference planes (e.g. the building floor) to the same point(s) on both the emitter and receiver to verify their mechanical alignment. If the units are to be positioned exactly vertical or horizontal to the floor, a carpenter's level is useful for checking alignment. Also check "by eye" for line-of-sight alignment. Make any necessary final mechanical adjustments, and hand-tighten the bracket hardware.

Connect the quick-disconnect (QD) cables to the emitter and receiver and route them (per local wiring code for low-voltage dc control cables) to the control box mounting location. The same cable type is used for both emitter and receiver: two cables are required per system. Cables are purchased separately, and may be cut to length at the time of installation. See page 34 for a listing of available cable lengths. The total length of the emitter and receiver cables may not exceed 175 feet.

Mount the MACHINE-GUARD System control box in a convenient location that is visible to the operator and free from heavy impulse force and high-amplitude vibration. Mounting hole information is given in Figure 13 (page 18). NOTE: The controller module will be installed later in Section 3.5.3.

\*A detailed alignment procedure is given in Section 6.1.

### 3.4 Controller Module Configuration

The MACHINE-GUARD Controller module must be properly configured *before* initial checkout and use. Controller configuration is done at the row of DIP switches along the edge of the controller module (Figure 8).

The parameters to be configured are:

- MACHINE-GUARD array length,
- number of beams (0 or 1) for floating blanking.

Because it has redundant microprocessors, the controller module has two identical DIP switch banks (bank A and bank B) which must be set identically. Failure to set both banks identically will bring about a lockout condition when power is applied to the control box. A switch pushed to the left is "on"; a switch pushed to the right is "off". Set the configuration switches as follows:

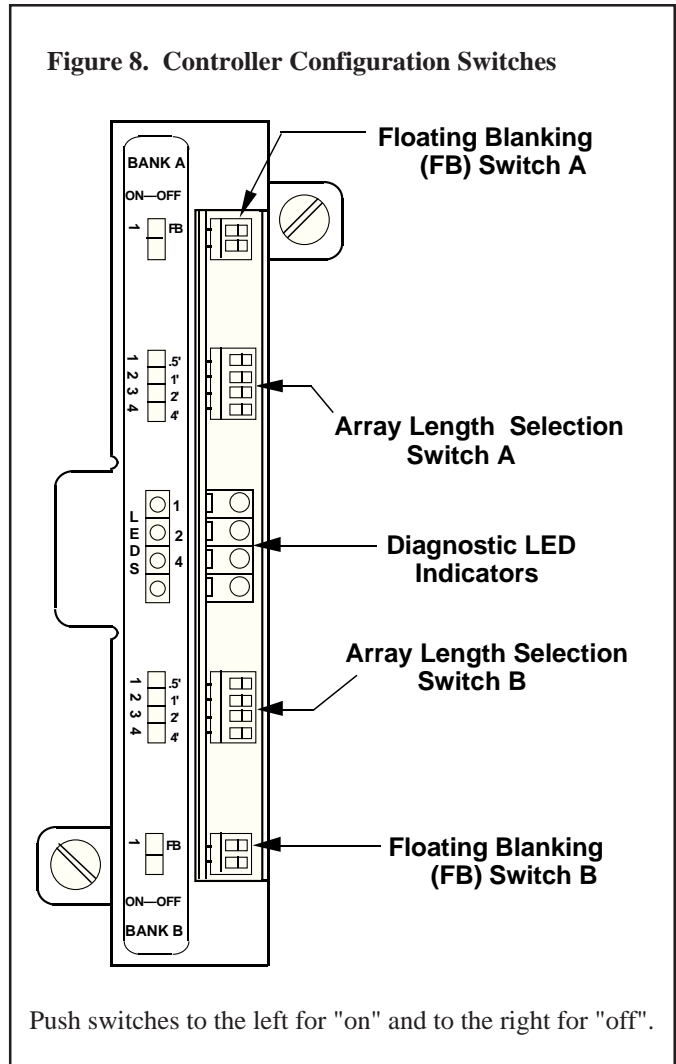

## CAUTION

Floating blanking increases  $D_{pf}$ . You must add the penetration factor ( $D_{pf} = 7$  inches) to calculate the separation distance whenever floating blanking is used.

Always turn floating blanking "off", when not required, to return minimum object sensitivity to 1.50 inch.



## WARNING

Electrical hookup must be made by a qualified electrician, and must comply with NEC (National Electrical Code) and local standards. Also, make no more connections to the MACHINE-GUARD System than are described in Sections 3.5.1 through 3.5.6. Connection of other wiring or equipment to the MACHINE-GUARD System could result in a dangerous situation.

### Array length configuration

Locate the array length configuration switches (Figure 8). Set switch banks A and B identically for the length of the emitter and receiver in use, as follows\*\*:

6" models	Switch #1 "on" (push switches to left for "on")
12" models	Switch #2 "on"
18" models	Switches #1 and 2 "on"
24" models	Switch #3 "on"
30" models	Switches #1 and 3 "on"
36" models	Switches #2 and 3 "on"
42" models	Switches #1, 2, and 3 "on"
48" models	Switch #4 "on"
54" models	Switches #1 and 4 "on"
60" models	Switches #2 and 4 "on"
66" models	Switches #1, 2, and 4 "on"
72" models	Switches #3 and 4 "on"

\*\*Set all other switches to "off". Refer to page 33, if necessary, for emitter/receiver lengths and corresponding model numbers.

### Floating Blanking configuration

Locate the floating blanking (FB) configuration switches in bank A. One light beam may be "floating blanked". This one blanked beam will allow an object of less than one inch in cross section to be inserted through the defined area *at any*

point without tripping the FSD output relays. (Section 2.2.) Switch #1 (only) blanks one beam. Switch #2 is not used, and its position has no effect. If *no* floating blanking is desired, set switch #1 to "off". Set the switches identically at banks A and B. See **Caution**, right.

### 3.5 Electrical Hookup and Checkouts

Make the electrical connections in the order that they are presented in Sections 3.5.1 through 3.5.5. If the controller module has already been installed in the control box, remove it by loosening the two captive screws and gently sliding the board out. This protects the controller module and greatly facilitates box "knockout" removal and internal wiring.

The following wiring connects inside the control box:

- Emitter and receiver cables,
- AC power,
- Output relay connections (FSD1, FSD2, and SSD), and
- Auxiliary Monitor Relay,
- Remote devices (LED Status Displays, key switch, etc.).

Several conduit knockouts are provided around the sides of the control box. There are seven knockouts for 1/2" conduit and four for 3/4" conduit (shown in Figure 9). The large knockouts are intended for the sensor cables. As you complete the wiring in the following sections, select knockout locations which allow easy and neat routing of cables to and from the control box. NOTE: Except for emitter and receiver cable entries (for which cable glands are supplied), it is the user's responsibility to maintain NEMA 13 sealing at all cable entries into the control box.

Note that the wiring barriers inside the control box can accept conductors no larger than #14 AWG. Also, the wires used should have an insulation temperature rating of at least 90°C (194°F).

**Figure 9. MACHINE-GUARD Control Box Knockout Locations**

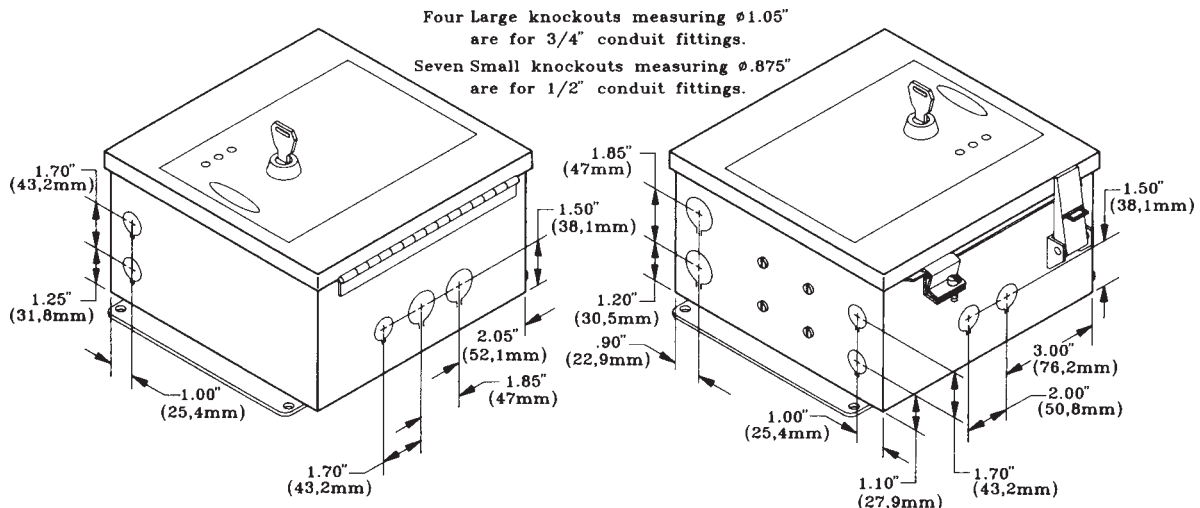

### 3.5.1 Emitter and Receiver Hookup

The emitter and receiver cables require two of the 3/4" knockouts (1.12" diameter holes). Two cable gland strain relief fittings are supplied with each control box for the entrance of the emitter and receiver cables into the control box. Emitter and receiver cables both connect to wiring barrier P2 (Figure 10, page 14). *Only the use of Banner QDC Series cables can ensure reliable communication of data between the controller and the receiver.* Match the color-coded terminals of wiring barrier P2 to colors of the wires in each 5-conductor cable. **Double-check your wiring. Incorrect wiring can lead to component damage.** There are no user adjustments or connections inside the MACHINE-GUARD sensors themselves.

### 3.5.2 AC Power (temporary connection)

As shown in Figure 12 (page 17), the ac lines to the control box connect through the MPCE monitor contacts of the guarded machine. However, do not wire to the MPCEs at this time. Instead, *temporarily* connect ac power directly at the L and N terminals of control box wiring barrier P6. Connect earth ground at the ground lug provided. This will allow the MACHINE-GUARD System to be checked out, by itself, before permanent ac connections through the guarded machine's monitor contacts are made. *Permanent* ac power connection will be made after MACHINE-GUARD System initial checkout, and is covered in Section 3.5.5.



## WARNING

Electrical shock hazard exists when the MACHINE-GUARD System has power applied to it and the control box door is open. Use extreme caution to avoid electrical shock during installation or servicing or when the control box door is open to change the switch configuration or observe the diagnostic indicators.

Always disconnect all power from the MACHINE-GUARD System and the guarded machine before making any wire connections or before replacing any component.

**Figure 10. MACHINE-GUARD System Electrical Connections**

NOTE 1: It is the user's responsibility to provide NEMA 13 (IP 64) sealing at the ac power and output relay control box cable entries.  
NOTE 2: Wiring barrier P3 is used for hookup of remote accessories. Refer to the hookup information included with each accessory.

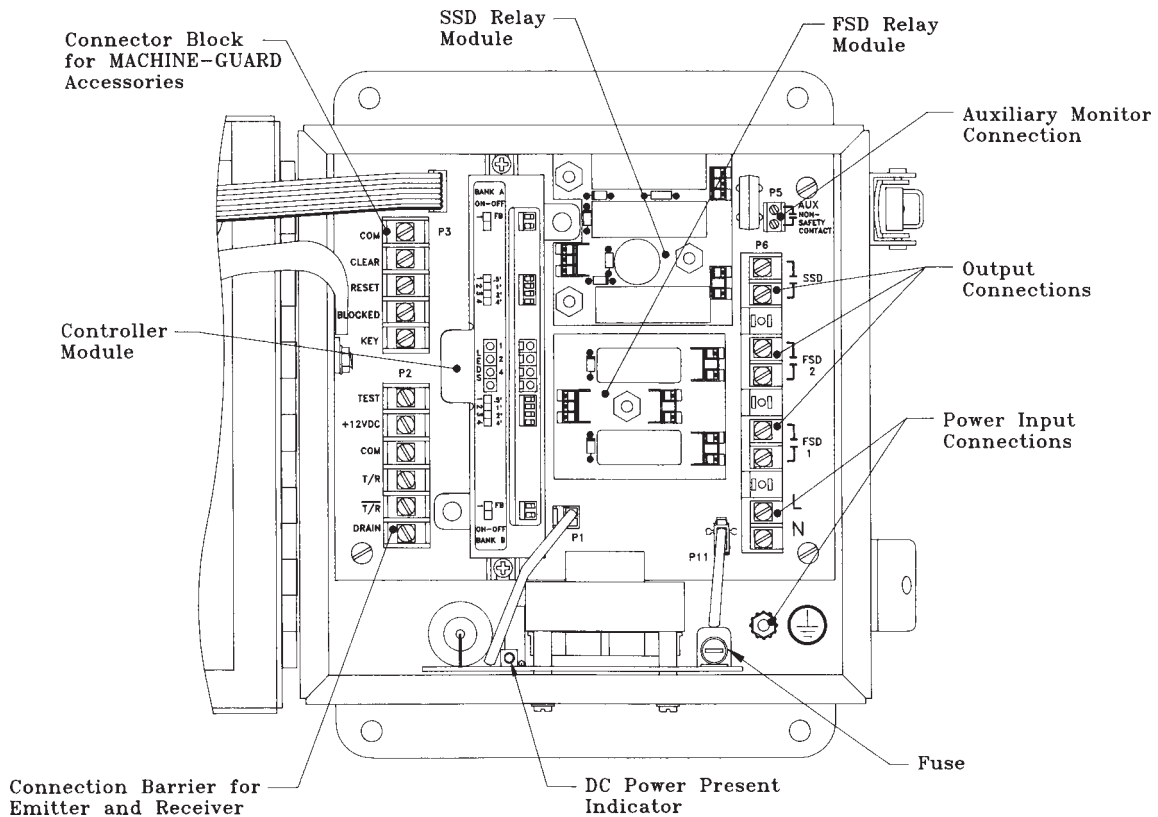

### 3.5.3 MACHINE-GUARD System Initial Checkout

This initial checkout procedure must be performed by a *qualified person* (see WARNING, page 9). It must be done **after** connecting the emitter and receiver (Section 3.5.1) and temporary ac power (Section 3.5.2) to the MACHINE-GUARD control box, but **before** the MACHINE-GUARD System is connected to the machine to be controlled.

This initial checkout procedure is performed when the MACHINE-GUARD System is first installed, and must also be performed by a **qualified person** whenever any maintenance or modification is performed on the MACHINE-GUARD System or on the machinery guarded by the MACHINE-GUARD System. NOTE: A schedule of required checkouts is given in Section 4.2.

You may now install the controller module. **Before doing so, make sure that ac power to the MACHINE-GUARD System is switched off.** Then refer to Figure 10 and gently slide the module into position, and tighten the two captive holddown screws.

#### INITIAL CHECKOUT PROCEDURE:

The MACHINE-GUARD System has three operating modes: POWER UP, KEY RESET, and RUN. Monitor the three control box panel LEDs (red, yellow, and green, on the front panel) and refer to Figure 11. The initial checkout procedure is as follows:

1) **Enter the POWER UP mode** by applying ac power to the control box (see CAUTION, right). The System will "power up" in a lockout condition (yellow LED only will flash).

2) **Enter the key RESET mode** by turning the key to the RESET position. The yellow panel LED will glow steadily. (Hold the switch in the RESET position for at least one-half second. This allows time for the microprocessors to run a startup diagnostic check routine.)

3) **Enter the RUN mode** by turning the key to the RUN position.

If the red LED (only) lights and flashes when the system is placed in the RUN mode, an *internal lockout condition* exists. Refer to Section 5.1 to determine the cause of the lockout.

If the red and yellow LEDs come "on" and glow steadily, the defined area is not clear (one or more light beams are obstructed) or the system may be out of alignment. This is a *trip condition*. If this occurs, recheck any blanking settings and check the defined area for obstructions.

If the MACHINE-GUARD System is properly aligned and the blanking is properly set and all obstructing objects are removed from the defined area, the green and yellow LEDs should come "on" after step #3 has been performed (the green LED will *flash* if blanking is "on"). **If you are setting up the MACHINE-GUARD System for the first time, or if the green LED does not come "on" in step #3, perform the alignment procedure in Section 6.1.** When you are certain that the emitter, receiver, and mirrors (if used) are aligned properly, tighten the emitter and receiver mounting hardware in position and repeat steps #1-3, above.



## CAUTION

Dangerous voltages are present inside the MACHINE-GUARD System control box whenever ac power to the system is "on".

Close the hinged control box cover and secure the latches before running this checkout procedure.

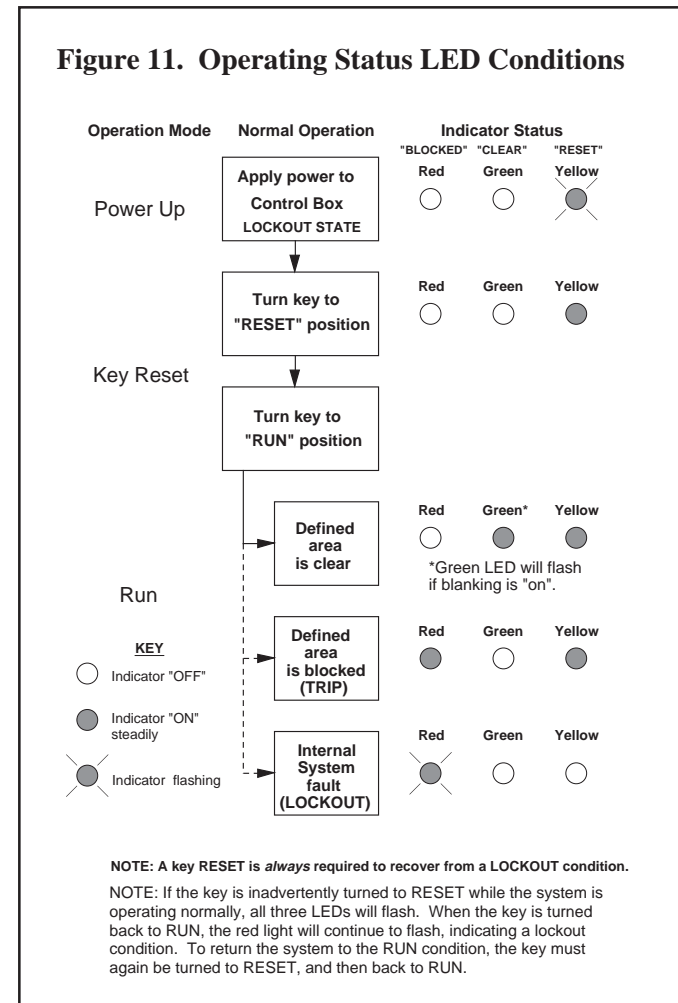

4) Next, "trip test" the MACHINE GUARD for object detection capability using the 1.50" diameter specified test piece supplied with the control box. There are two trip test procedures. The one to use depends upon whether or not floating blanking is being used. To perform the trip test, the key switch must be in the RUN position and the green and yellow LEDs must be "on" The green LED will *flash* if blanking is "on".

a) **If floating blanking is not being used**, pass the specified test piece, very slowly, down the length of the defined area in three paths: close to the emitter unit, close to the receiver unit, and midway between the emitter and receiver units. The red and yellow (only) LEDs must come "on" when the test piece enters the defined area, and must remain "on" for as long as the test piece remains in the defined area. When the test piece is removed from the defined area, the green and yellow (only) LEDs must come "on".

b) **If floating blanking is being used**, temporarily block *one beam only* of the defined area using heavy opaque tape or an opaque object. It is usually easiest to block either the lowest or highest beam. With this one beam blocked, proceed as in paragraph 4a (page 15).

If the MACHINE-GUARD System passes all of the checks in Section 3.5.3, go on to Section 3.5.4. If the MACHINE-GUARD System fails any of these checks, *do not attempt to use it until the reason for the failure(s) is identified and the failures are corrected.* **NOTE:** Consider the caution about reflective surfaces (page 11) when assessing the cause of a failed trip test.

### 3.5.4 Output Relay Connections

Output relay connections are made at the **FSD1** (Final Switching Device 1), **FSD2** (Final Switching Device 2), and **SSD** (Secondary Switching Device) terminals on wiring barrier P6. These relays are energized (contacts closed) in normal operation with no obstructions in the defined area. **All** relays become de-energized (their contacts open) in a lockout condition. Relays **FSD1** and **FSD2** (only) de-energize in a trip condition. Before continuing, read the **NOTICE regarding MPCEs**, right.



## WARNING

The MACHINE-GUARD System's output relays must be the *final switching devices* for the machinery being guarded. Do not wire in any intermediate control devices between the output relays and the control elements of the guarded machinery. To do so could result in serious injury or death.

*Never connect the MACHINE-GUARD System to the top stop circuitry of a press.*

## NOTICE regarding MPCEs

Each of the two Machine Primary Control Elements (MPCE 1 and MPCE 2) must be capable of immediately stopping the dangerous machine motion, irrespective of the state of the other. These two channels of machine control need not be identical, but the stop time performance of the machine ( $T_s$ , used to calculate the separation distance) must take into account the *slower* of the two channels.

Some machines offer only one primary control element. For such machines, it is necessary to duplicate the circuit of the single MPCE to add a second machine primary control element. Refer to Figure 12 (page 17) or consult the machine manufacturer for additional information.

## NOTICE regarding MPCE Monitoring Hookup

It is strongly recommended that one normally open and one normally closed auxiliary contact of each MPCE be wired (as shown in Figure 12, page 17) as MPCE monitor contacts. If this is done, any inconsistency of action between the two MPCEs will remove power from the MACHINE-GUARD System, causing a lockout condition. ***The use of MPCE auxiliary contacts as MPCE monitor contacts is necessary in order to maintain redundancy.*** MPCE auxiliary contacts used for this purpose must be rated at 130V ac minimum, 50 VA minimum.

**In order to maintain redundancy, the MPCE monitor contacts must be wired as described in section 3.5.5 and Figure 12, page 17.**



The **FSD1 output relay** connects to Machine Primary Control Element #1 (MPCE 1) on the guarded machine. MPCE 1 is an electrically powered element of the guarded machine that directly controls the machine's normal operating motion in such a way that it is last (in time) to operate when motion is either initiated or arrested. The output contact of relay FSD1 must be connected, as shown in Figure 12, to control power to Machine Primary Control Element #1. The switching capacity of relay FSD1 is 250V ac max., 4 amps max. (resistive load).

The **FSD2 output relay** connects to Machine Primary Control Element #2 (MPCE 2) on the guarded machine. MPCE 2 is an electrically powered element of the guarded machine (in a different control path than MPCE 1) that directly controls the guarded machine's normal operating motion in such a way that it is last (in time) to operate when machine motion is either initiated or arrested. The output contact of relay FSD2 must be connected, as shown in Figure 12, to control power to Machine Primary Control Element #2. The switching capacity of relay FSD2 is 250V ac max., 4 amps max. (resistive load).

Many different types of mechanisms are used to arrest dangerous machine motion. Examples include mechanical braking systems, clutch mechanisms, and combinations of brakes and clutches. Additionally, control of the arresting scheme may be hydraulic or pneumatic.

As a result, MPCEs may be of several control types, including a wide variety of contactors and electro-mechanical valves. If your machine documentation leaves any doubt about the proper connection points for the MACHINE-GUARD System output relay contacts, *do not make any connections*. Contact the machine builder for clarification regarding connections to the MPCEs and MSCE.

The **SSD output relay** connects to the Machine Secondary Control Element (MSCE) on the guarded machine. The MSCE is an electrically powered element of the guarded machine (independent of the MPCEs) that is capable of removing power from the prime

Figure 12. Generic Machine Interface

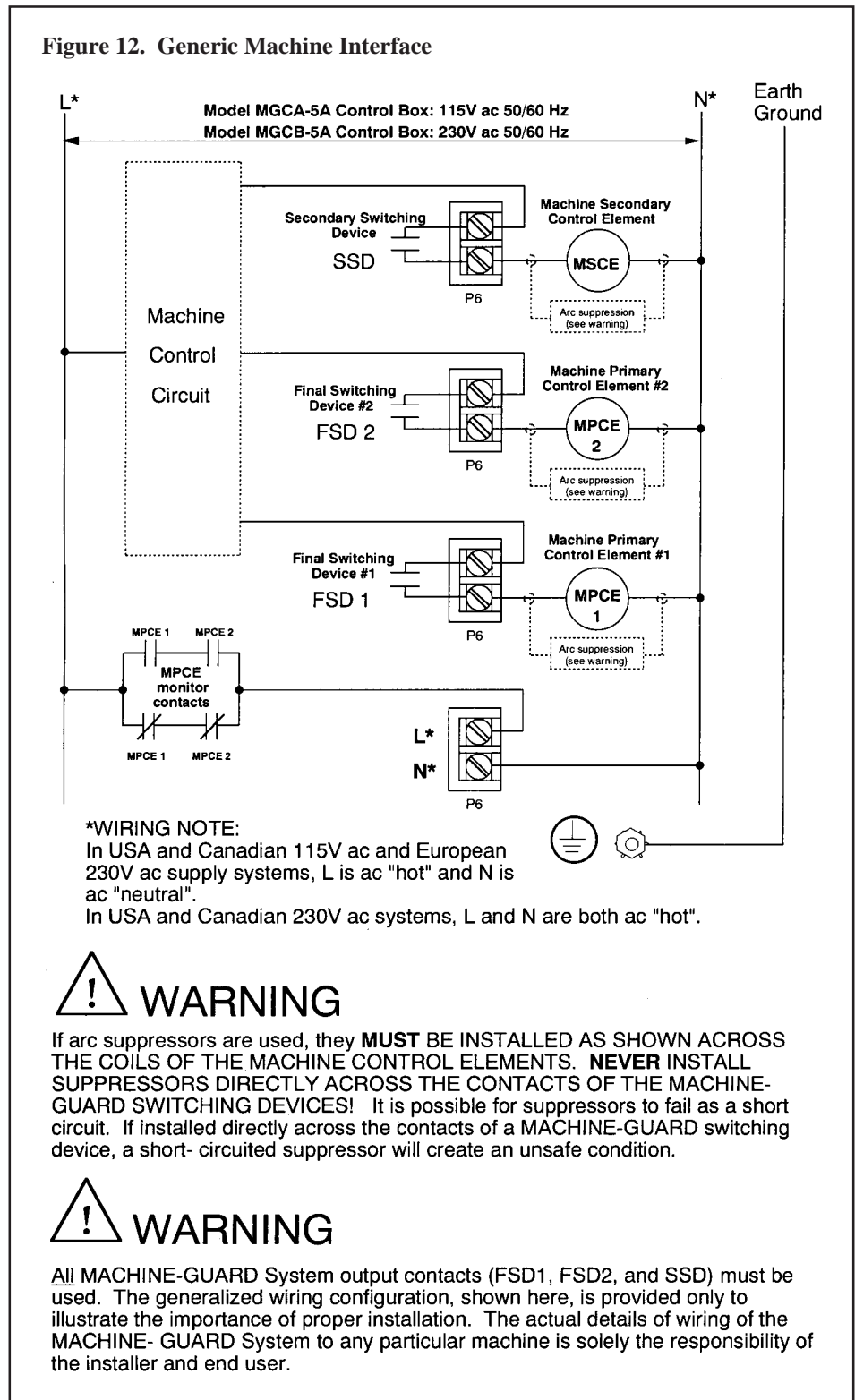

(continued on page 20)

# Figure 13. Dimensions, MACHINE-GUARD System

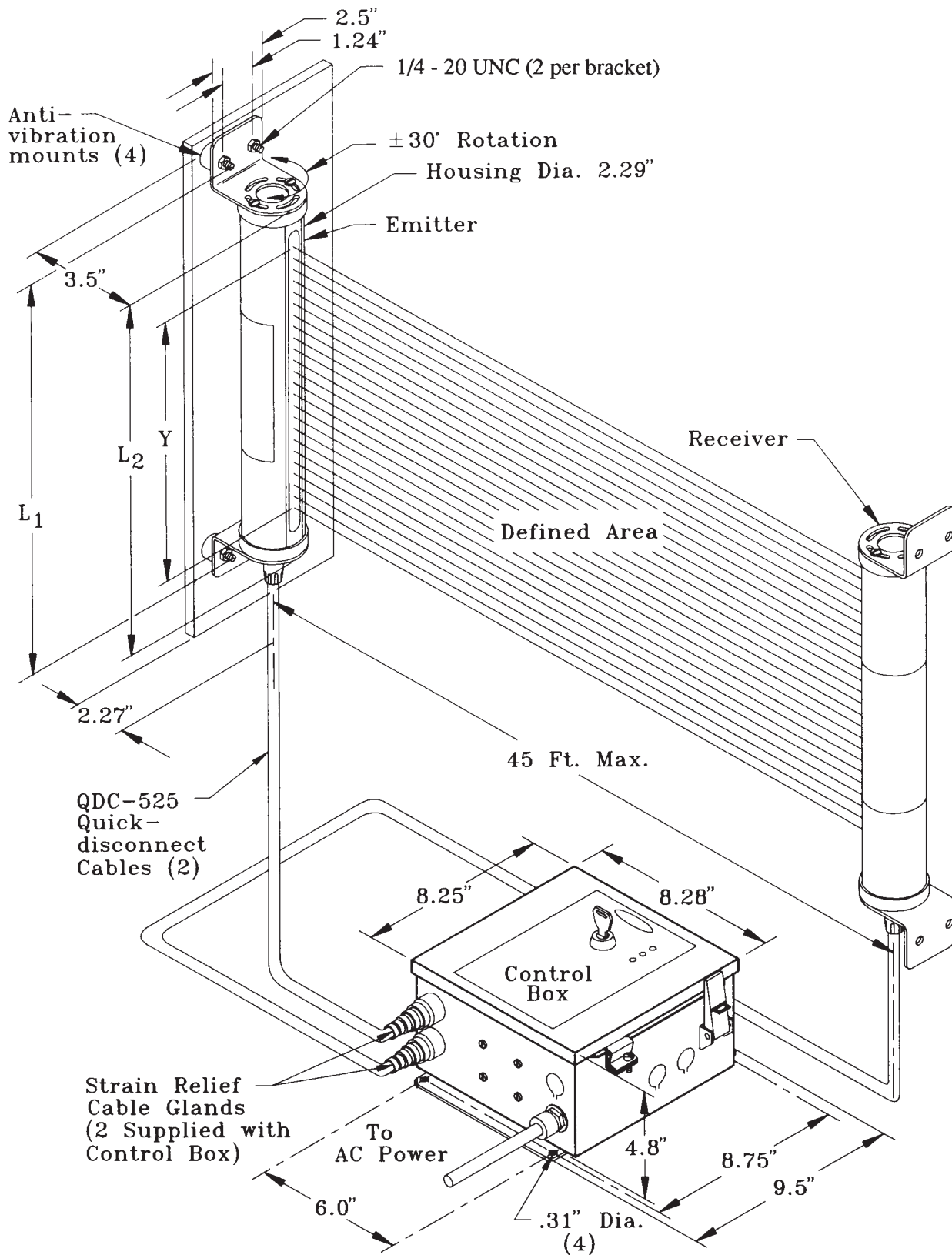

Sensor Models	Ht. of Defined Area (Y)	Mounting Dimensions	
		(L1)	(L2)
MGE616A emitter MGR616A receiver	6 inches (152 mm)	11.7" (297 mm)	9.6" (244 mm)
MGE1216A emitter MGR1216A receiver	12 inches (305 mm)	17.7" (449 mm)	15.6" (396 mm)
MGE1816A emitter MGR1816A receiver	18 inches (457 mm)	23.7" (602 mm)	21.6" (549 mm)
MGE2416A emitter MGR2416A receiver	24 inches (610 mm)	29.8" (757 mm)	27.6" (701 mm)
MGE3016A emitter MGR3016A receiver	30 inches (762 mm)	35.8" (909 mm)	33.6" (853 mm)
MGE3616A emitter MGR3616A receiver	36 inches (914 mm)	41.8" (1062 mm)	39.7" (1008 mm)
MGE4216A emitter MGR4216A receiver	42 inches (1067 mm)	47.8" (1214 mm)	45.7" (1161 mm)
MGE4816A emitter MGR4816A receiver	48 inches (1219 mm)	53.9" (1369 mm)	51.7" (1313 mm)
MGE5416A emitter MGR5416A receiver	54 inches (1372 mm)	59.9" (1521 mm)	57.7" (1466 mm)
MGE6016A emitter MGR6016A receiver	60 inches (1524 mm)	65.9" (1674 mm)	63.7" (1618 mm)
MGE6616A emitter MGR6616A receiver	66 inches (1676 mm)	71.9" (1826 mm)	69.7" (1770 mm)
MGE7216A emitter MGR7216A receiver	72 inches (1829 mm)	77.9" (1979 mm)	73.7" (1872 mm)

### Emitter/receiver Mounting Bracket Dimensions

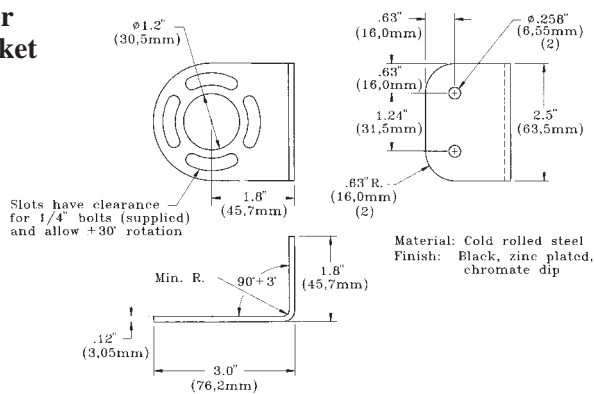

### Quick Disconnect Cable

Emitter and receiver cables must be ordered separately from the rest of the system. Banner cables have a straight QD (Quick Disconnect) connector molded onto the sensor end. Cables measure .5-inch in diameter, and are PVC-jacketed. Conductors are 16-gauge.

Cables are available in lengths of 25, 50, 100, and 150 feet. Total length of the emitter and receiver cables must not exceed 175 feet. See page 34 for cable models.

The threaded, knurled connector is aluminum. Two liquid-tight cable gland/strain relief fittings are supplied with each control box to admit the emitter and receiver cables through the selected knockouts on the control box wall.

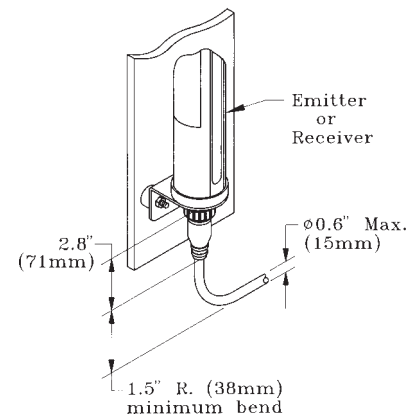

### WARNING

The MACHINE-GUARD System's emitters and receivers must be installed with their corresponding ends (either cabled ends or non-cabled ends) pointing in the same direction (i.e. both cabled ends "up", both cabled ends "down", etc.). Failure to do this will impair the performance of the MACHINE-GUARD System and result in incomplete guarding. See Figure 13 (left, both cabled ends "down"). Failure to observe this warning could result in serious injury or death.



## WARNING

### Using MACHINE-GUARD Systems for Perimeter Guarding...

If a BEAM-ARRAY™ MACHINE-GUARD System is installed for use as a perimeter guarding system, the Machine Primary Control Elements (MPCEs) of the guarded machine must be wired such that any interruption of the defined area will cause immediate arrest of the dangerous motion of the guarded machine. Following any interruption, the dangerous machine motion must be able to be initiated *only* by actuation of a reset switch. This reset switch must be located outside of the area of dangerous motion, and must be positioned so that the area of dangerous motion may be observed by the switch operator during the reset operation.

mover of the dangerous part of the machine in the event of an emergency. The output contacts of the SSD relay must be connected, as shown in Figure 12, to the Machine Secondary Control Element such that, if a lockout condition occurs, the motive power will be removed from the machine. The switching capacity of the SSD relay is 250V ac max., 4 amps max. (resistive load).

**Figure 13 shows output relay connections in a generic interfacing situation.** The connections between the MACHINE-GUARD System outputs and the machine primary and secondary control elements must be direct, and arranged so that any single line fault or earth fault will not result in a circuit failure to a potentially dangerous state.

#### 3.5.5 AC Power (permanent connection)

After the initial checkout of Section 3.5.3 has been successfully completed, the ac lines to the MACHINE GUARD System must be re-routed to their permanent hookup, through the guarded machine's MPCE monitor contacts. This is important: it ensures that any inconsistency in action between the two MPCEs will remove power from the system. (This is discussed in **NOTICE regarding MPCE Monitoring Hookup, p. 16**).

Connection to ac power is at the **L** and **N** terminals of control box wiring barrier P6. The MACHINE-GUARD System requires 115V ac, 50/60Hz using control box MGCA-5A, or 230V ac using model MGCB-5A. Three-wire connection

(ac "hot", ac "neutral", and earth ground) to ac power mains must be done according to NEC and local wiring codes. A wire lug to attach to the grounding stud is supplied with the control box hardware kit. *Do not operate the MACHINE-GUARD System without an earth ground connection.*

After ac power has been connected to the MACHINE-GUARD System and the output relay contacts have been connected to the machine to be controlled, the operation of the MACHINE-GUARD System with the guarded machine must be verified before the combined system may be put into service. To do this, **a qualified person must perform the Commissioning Checkout Procedure given in Section 6.2 on page 29.**

#### 3.5.6 Auxiliary Monitor Relay

The action of the Auxiliary Monitor Relay contact "follows" the action of output relays FSD1 and FSD2. The Auxiliary Monitor Relay contact is a light-duty contact used for *control functions that are not safety-related*. A typical use is to communicate with a programmable logic controller (PLC). The switching capacity of the Auxiliary Monitor Relay is 125V ac or dc max., 500mA max. Connection to the Auxiliary Monitor Relay contact is made at wiring barrier P5.

#### 3.5.7 Accessory Connections at Terminal Strip P3

Terminal strip P3 at the upper left corner of the control box allows connection of accessories such as the MGA-LR Series LED Remote Displays and the MGA-KSO-1 Remote Key Switch. Refer to the data sheets for these products for hookup information. **If the connected accessory is or includes a remote reset switch, the accessory must be positioned at a location that provides an unobstructed view of the entire defined area.**

#### 3.6 Control Box Latch Adjustment

The tightness of the upper (lockable) latch on the control box is adjustable. Rotating the threaded clasp of the latch counterclockwise loosens the latch, while rotating the clasp clockwise tightens the latch. Adjust the threaded clasp so that the box cover is held closed snugly when the latch is in the closed (locked down) position.

## 4. Operating Instructions

### 4.1 Security Protocol

The MACHINE-GUARD control box has a **locking latch** and a **key-operated front-panel RESET switch**.

In order to prevent access by unauthorized personnel, and to ensure that all lockout conditions come to the attention of a person qualified to deal with them, a lock must be inserted in the locking latch and the key (or combination) to this lock must be kept in the possession of a *qualified person* as



**WARNING** The Banner MACHINE-GUARD System can do the job for which it was designed only if it and the guarded machine are operating properly, both separately and together. It is your responsibility to verify this, on a regular basis, as instructed in Section 4.2 and Section 6.

If the MACHINE-GUARD System and the guarded machine do not perform *exactly* as outlined in the checkout procedures, the cause of the problem must be found and corrected before the system is put back into service. Failure to correct such problems can result in serious injury or death.

defined in ANSI/ASME B30.2-1983 (see *Glossary* Section) **Qualified persons only** should have access to the **interior** of the MACHINE-GUARD System control box.

The key to the **front-panel RESET switch** should be available to a **designated person** or persons. A designated person is one who is identified and designated in writing, by the employer, as being appropriately trained and qualified to perform a specified checkout procedure. If the machine operator meets these requirements, he/she may be a designated person.

## 4.2 Periodic Checkout Requirements

In addition to the checkouts that are done by a qualified person or persons at the time that the MACHINE-GUARD System is installed and put into service, **the functioning of the MACHINE-GUARD System and the guarded machine must be verified on a regular periodic basis to ensure proper operation. This is absolutely vital and necessary. Failure to ensure proper operation can lead to serious injury or death.**

Checkouts must be performed as follows:

- 1) By a designated person at every power-up of the MACHINE-GUARD System (use checkout procedure 6.2, page 29),
- 2) By a qualified person following the correction of every lockout condition (use checkout procedure 6.3, page 29),
- 3) By a designated person at every shift change or machine setup change (use checkout procedure 6.3, page 29),
- 4) By a qualified person semi-annually (every 6 months) following installation of the MACHINE-GUARD System (use checkout procedure 6.4, page 30).

## 4.3 Normal Operation

### 4.3.1 Power-up

When ac power is applied to the MACHINE-GUARD System, it is normal for it to "power up" into a lockout condition. To prepare the MACHINE-GUARD System for operation after a "power-up" lockout, the designated person must perform a key reset (refer to Figure 14, right):

- a) Turn the key to the RESET position (red LED goes "on"). Wait at least one-half second, then
- b) Turn the key to the RUN position.

**If the defined area is clear**, the green\* and yellow LEDs will go "on" (red LED goes "off"). **If the defined area is blocked or if the emitter and receiver are misaligned**, the red and yellow LEDs will go "on". Now perform checkout procedure 6.2 on page 29.

**Figure 14. Operating Status LED Conditions**

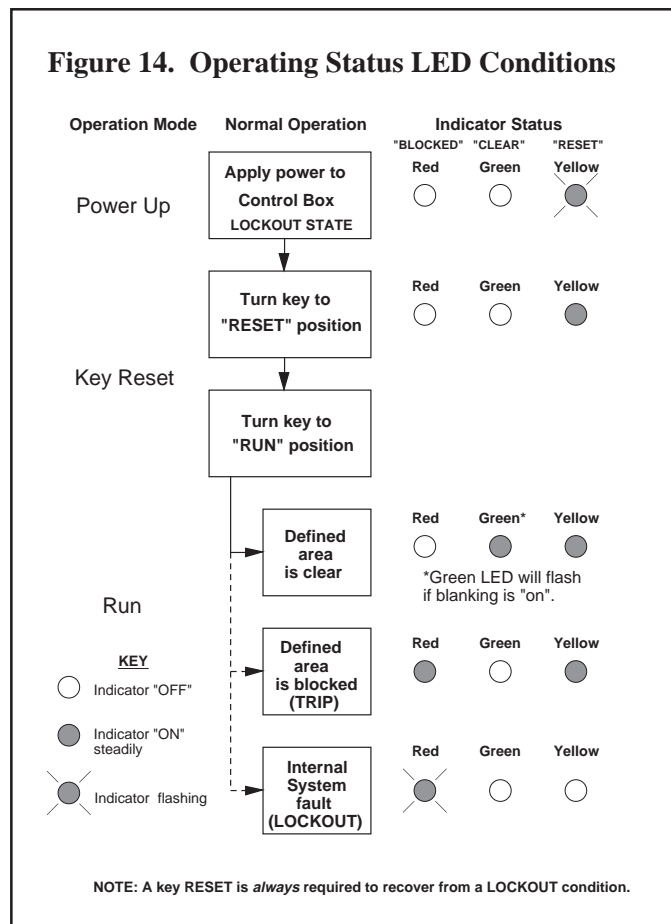

**\*If blanking is "on", the green LED will flash.**

### 4.3.2 Floating Blanking Operation

Floating blanking allows an object of up to one inch in cross section to break the defined area at any point without causing a "trip" condition (see Section 2.2).

The use of floating blanking increases the Penetration Depth Factor ( $D_{pf}$ ) and also, therefore, the separation distance required between the defined area and the closest machine danger point (see Figure 6 on page 11, and Section 3.2.1). If the separation distance was calculated on the basis of no floating blanking and you later begin to use floating blanking, OSHA regulations require the separation distance to be increased accordingly. See Section 3.2.1.

*Upon power-up (and also at every shift change or machine setup change), checkout procedure 6.2 on page 29 must be performed.*

## 5. Troubleshooting and Maintenance

### 5.1 Troubleshooting Lockout Conditions

A MACHINE-GUARD System lockout condition will occur:

- 1) Routinely upon MACHINE-GUARD System "power-up" (see Section 4.3.1),
- 2) If ac power to the MACHINE-GUARD System is interrupted,
- 3) If only one FSD (Final Switching Device) relay has gone to the "off" state (de-energized),
- 4) If the SSD (Secondary Switching Device) relay has de-energized,
- 5) If the controller module switch settings are incorrect for the emitter/receiver array length in use, or
- 6) If the self-checking circuits of the microprocessor detect a component failure.

A lockout condition causes all output relays (FSD1, FSD2, and SSD) plus the auxiliary monitor relay to open, shutting down the MPCEs and MSCE of the guarded machine. A lockout condition is indicated by the red LED (only) on the front panel flashing.

Use the following procedure to resume operation after a power interruption (condition #2):

- a) Turn the key to the RESET position (red Status Indicator LED should light) and wait at least one-half second,
- b) Turn the key to the RUN position:

If defined area is clear and the emitter and receiver are properly aligned, the green and yellow LEDs will light. If the lockout condition was due to a momentary power interruption that has been corrected, the MACHINE-GUARD System will now operate normally.

*Upon recovery from a power interruption, checkout procedure 6.2 on page 29 must be performed.*



## WARNINGS

**Power failures or other MACHINE-GUARD System lockout conditions should always be investigated immediately by a qualified person.** *With the exception of lockout conditions #1 and #2 (left), lockout is a positive indication of a problem and should be investigated at once.* Attempts to operate machinery by bypassing the MACHINE-GUARD System are dangerous and could result in injury or death.

**Electrical shock hazard exists when the MACHINE-GUARD System has power applied to it and the control box door is open.** Use extreme caution to avoid electrical shock during installation or servicing or when the control box door is open to change programming or observe the diagnostic indicators. **Always disconnect all power from the MACHINE-GUARD System and the guarded machine before making any wire connections or before replacing any component.**

**The control box should be opened and/or serviced only by a qualified person (see Section 4.1).**

**If all three Status Indicator LEDs are flashing,** the key reset switch has been turned to the RESET position while the MACHINE-GUARD System was operating normally. To resume operation, turn the key reset switch to the RUN position, then to the RESET position, and back again to the RUN position.

**If the Status Indicator LEDs will not operate,** the lockout condition is due to another cause (conditions #3-6). In this case, the qualified person must open the control box cover and note the state of the Diagnostic Indicator LEDs (Fig. 15, page 23).

If one or more of the red Diagnostic Indicator LEDs is "on", the cause of the lockout condition is *within* the MACHINE-GUARD System. The MACHINE-GUARD System will not operate if its self-checking circuits have detected an internal problem. Take the corrective measure(s) shown in Figure 15 for the listed Error Number and related Problem. If further assistance is required, contact your Banner field service engineer or the factory Applications Engineering Department.

If no Diagnostic Indicator LEDs are "on", ac power to the system *may* have been lost. The green LED on the power supply board (see Figure 10, page 14) indicates the presence (LED "on") or absence (LED "off") of **dc power at the power supply board.** It is possible for **ac power** to be present at the input of the power supply even if the dc power LED is "off". **Exercise care. A shock hazard may exist under these conditions.**

**Figure 15. Interpretation of Diagnostic Indicator LEDs**

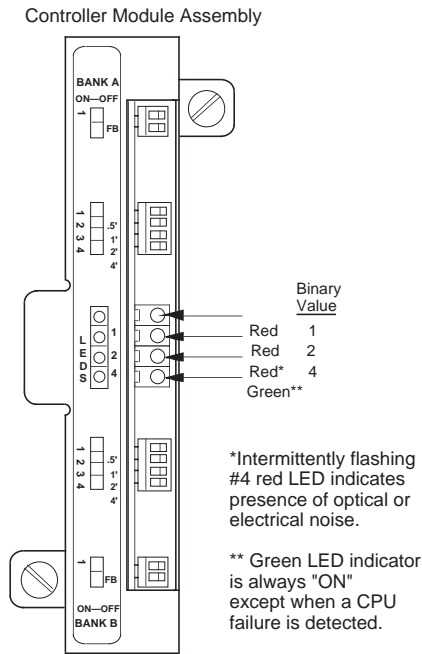

Error Number (Add binary values of lighted red LEDs)	Problem	Correction
0	System is O.K.	—————
1	A.) Relay failure B.) Controller module failure C.) Unnecessary key reset	A.) Replace relay module (MGA-RMSSD) B.) Replace controller module C.) Perform a key reset
2	A.) Waiting for a key reset B.) Relay failure C.) Key switch failure	A.) Perform a key reset B.) Replace relay module (MGA-RMSSD) C.) Replace key switch (MGA-KS-1)
3	Controller module failure	Replace controller module
4*	Receiver failure	A.) Check cable connections B.) Replace receiver
5	Emitter failure	A.) Check cable connections B.) Replace emitter
6	A.) Incorrect configuration of array length. B.) Emitter failure C.) Controller module failure	A.) Check array length switch configuration (see page 12) B.) Replace emitter C.) Replace controller module
7	A.) Incorrect configuration of blanking area B.) Receiver failure C.) Controller module failure	A.) Check blanking switch configuration (see page 12) B.) Replace receiver C.) Replace controller module
8**	CPU failure	Replace controller module

**Very carefully check for ac voltage across the L and N terminals of wiring barrier P6.** If ac voltage is **not** present at L and N, ac power to the MACHINE-GUARD System has been lost, and the cause is outside the system. If voltage **is** present there, remove plug P11 from the relay board and check the P11 socket (on the board) for ac voltage. If ac voltage is **not** present there, the problem is in the FSD relay module. If voltage **is** present at the P11 socket, reconnect plug P11 and check for 12V dc at connector block P2. If 12V dc is **not** present there, turn off the ac power to the control box and check the fuse. If the fuse is bad, replace it (Section 5.2.1). If the fuse is good, and 12V dc is still **not** present at P2, a power supply failure has occurred.

## 5.2 Effects of Electrical and Optical Noise

The MACHINE-GUARD System is designed and manufactured to be highly resistant to "noise" and to operate reliably in industrial settings. However, serious electrical and/or optical "noise" may cause a random "trip" condition. In *very extreme cases*, a "lockout" is possible. In order to minimize the effects of transitory noise, the MACHINE-GUARD System will respond to noise only if the noise is detected on two consecutive scans. Red Diagnostic Indicator LED #4 will flash to indicate the presence of electrical or optical noise. This LED can be used to track down particularly offensive noise sources. Simply observe the LED while shutting down or isolating the suspected sources.

When the MGA-KSO-1 Remote Key Switch is used in extremely noisy conditions, we recommend the use of shielded cable between the control box and the key switch as a precautionary measure.

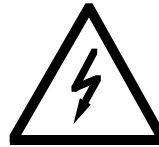

## CAUTION

Electrical shock hazard exists when the MACHINE-GUARD System has power applied to it and the control box door is open. Use extreme caution to avoid electrical shock during installation or servicing or when the control box door is open to change programming or observe the diagnostic indicators. **Always disconnect all power from the MACHINE-GUARD System and the guarded machine before making any wire connections or before replacing any component.**

**The control box should be opened and serviced only by a qualified person (see Section 4.1).**

## 5.3 Servicing and Maintenance

### 5.3.1 Fuse Test and Replacement

**Turn off ac power to the control box before proceeding.**

The MACHINE-GUARD System control box fuse is located in a fuseholder on the power supply board (see Figure 10, page 14). Use a flat-blade screwdriver to push in and rotate the end of the fuse holder counterclockwise until it and the fuse can be pulled from the holder. Visually inspect the fuse and/or test its conductivity using an ohm meter or a continuity tester. The fuse is a 250V ac 3AG slow-blow type (see specifications, page 33).

### 5.3.2 Controller Module and Relay Replacement

MACHINE-GUARD Systems are designed for reliability. While replacement of the controller module and relays is not normally required, these components have been designed to be easily replaceable as a convenience to the customer. **To maintain control reliability, use only Banner-supplied replacement relays with forced-guided contacts.**

The controller module may be removed from the control box by loosening the two captive screws which hold it in place, and gently sliding the board out of the box. To reinstall the controller module, reverse the sequence: slide the board into place until snug, and tighten down the two captive screws.

The output relays are configured in two modules: the FSD relay module and the SSD relay module (see Figure 10, page 14). To remove a module, remove the 3/8" nylon hex nuts and gently slide the module out of the control box to disconnect it from the mother board. To reinstall, press the module firmly and evenly onto its connector pins and replace the hex nuts.

**NOTE: Do not open the emitter or receiver housing.** The emitter and receiver contain no field-replaceable components. If repair is necessary, return the unit to the factory. Do not attempt to repair an emitter or receiver yourself.

**If it ever becomes necessary to return any MACHINE-GUARD component to the factory, pack it carefully:**

- Remove the controller module from the control box, and pack the module separately, and
- Use the original packing materials whenever possible. **Damage that occurs in return shipping is not covered by warranty.**

### 5.3.3 Emitter/receiver Alignment

Banner MACHINE-GUARD System emitter and receiver mounting hardware is designed to be highly resistant to misalignment due to vibration and shock. However, a persistent trip condition (yellow and red Status Indicator LEDs "on") that cannot be attributed to improper blanking or to a blockage in the defined area may be due to an emitter or receiver having been accidentally knocked out of alignment. If this is suspected, a qualified person should perform the following alignment procedure:

- 1) Disable the guarded machine so that its dangerous parts cannot move.
- 2) Slightly loosen the hardware holding the emitter unit to its top and bottom brackets, and rotate the emitter in its brackets until its window directly faces the receiver unit. **RESET** the MACHINE-GUARD System.
- 3) Slightly loosen the hardware holding the receiver unit to its top and bottom brackets. Rotate the receiver in its brackets until its window directly faces the emitter unit. The yellow and green Status Indicator LEDs should be "on" at this point. (NOTE: The green indicator will be *flashing* if blanking is "on".) Rotate the receiver back and forth to find the midpoint of the zone of movement within which the yellow and green LEDs remain "on". Do the same with the emitter, and then again with the receiver. Tighten the hardware to secure the emitter and receiver at these positions. NOTE: If the trip condition persists (yellow and red LEDs remain "on") review the procedure in Section 3.3 to verify that the emitter and receiver units are properly mounted relative to each other. For further assistance, contact the Banner Applications Engineering Department.

### 5.3.4 Cleaning

**The MACHINE-GUARD System control box** is constructed of welded steel with a black polyester paint finish, and is rated NEMA 13 (IP 64). It may be cleaned using mild detergent or window cleaner and a soft cloth.

**The MACHINE-GUARD System emitter and receiver units** are constructed of aluminum with a black anodized finish and are rated NEMA 4, 13 (IP65). Lens covers are acrylic. Emitters and receivers are best cleaned using mild detergent or window cleaner and a soft cloth. Avoid cleaners containing alcohol, as they may damage the acrylic lens covers.



## WARNING

**If replacement parts are ever required, always use only genuine Banner-supplied replacement parts.**

Do not attempt to substitute parts from another manufacturer. To do so could impair the operation of the MACHINE-GUARD System and result in a dangerous situation and possible injury or death.

**Aligning the MACHINE-GUARD System while the hazardous machinery is operational could result in serious injury.** You may be working close to the hazardous area of your machinery while aligning the MACHINE-GUARD System. *The machinery that the MACHINE-GUARD System is connected to must not be operating at any time during this procedure.*



## 6. Alignment and Checkout Procedures

Study each procedure from beginning to end to make sure that you understand each step before you start.

Refer all questions to the Banner Applications Engineering Department (address, telephone, and FAX information on page 2).

Section 6.1 is a procedure for optically aligning a MACHINE-GUARD System using corner mirror(s). Sections 6.2, 6.3, and 6.4 are periodic performance checkout procedures for the MACHINE-GUARD System, and are performed according to the schedule given in Section 4.2.

### 6.1 Alignment of the MACHINE-GUARD System

This alignment procedure begins with the assumption that the MACHINE-GUARD System has been mechanically aligned as discussed in Section 3.3. As is recommended there, we suggest maximizing the sensing power of the MACHINE-GUARD System through liberal use of hard-guarding and by keeping the number of corner mirrors (if used) in the System to a necessary minimum. Follow the measures outlined below to maximize MACHINE-GUARD System excess gain. If there are reflective surfaces near the defined area, read alignment step #7 (page 27), before proceeding further, to prevent possible reflection problems.

(continued on page 26)



**WARNING** You may be working close to the hazardous area of your machinery while aligning the MACHINE-GUARD System. Aligning the MACHINE-GUARD System while the hazardous machinery is operational could result in serious injury. *The machinery that the MACHINE-GUARD System is connected to must not be operating at any time during the alignment procedure of Section 6.1.*

## MGM Series Mirrors and the Maximum Width of the Defined Area

*Excess gain* is a measurement of the sensing energy that falls upon the receiver element of a sensing system over and above the minimum level required to just operate the receiver's amplifier. Excess gain may be used to predict the reliability of a sensing system. **The higher the excess gain, the better the ability of the sensing beam to cut through fog, mist, dust, and other contamination.** Excess gain decreases as the emitter-to-receiver distance (R) increases and as corner mirrors (n) are added to the System. Minimum excess gain recommendations are given in the table at the right. Maximization of excess gain should be an important objective when designing a MACHINE-GUARD setup.

The excess gain formula for the MACHINE-GUARD System with MGM Series mirrors is:

$$G_F = \frac{6075 (\text{REF})^n}{R^2}$$

where:  $G_F$  = final excess gain  
 $n$  = the number of mirrors used  
 REF = reflectance: .85 (glass mirrors)  
 $R$  = the total distance that the light travels (overall width of the defined area)

#### Example:

The excess gain of a 2-mirror MACHINE-GUARD System (glass mirrors) that is set up to guard a total distance of 10 feet would be:

$$G_F = \frac{6075 (.85)^2}{10^2} \approx 44$$

### Guidelines for Excess Gain Values

Minimum Excess Gain Required	Operating Environment
1.5X	<b>Clean air:</b> no dirt buildup on lenses or mirrors.
5X	<b>Slightly dirty:</b> slight buildup of dust, dirt, oil, moisture, etc. on lenses or mirrors. Lenses and mirrors cleaned on a regular schedule.
10X	<b>Moderately dirty:</b> obvious contamination of lenses or mirrors (but not obscured). Lenses and mirrors cleaned occasionally or when necessary.
50X	<b>Very dirty:</b> heavy contamination of lenses and mirrors. Heavy fog, mist, dust, smoke, or oil film. Minimal cleaning of lenses and mirrors.

*Always maintain at least the minimum excess gain indicated in the table (above) for the environment in which you are operating. Tips for maximizing excess gain are:*

- 1) Use "hard guarding" where possible to reduce the overall defined area width and the number of mirrors required.
- 2) Keep sensors and mirrors properly aligned,
- 3) Keep red sensor lens covers and mirrors clean.

## Alignment of the MACHINE-GUARD System (continued)

Only a **qualified person** may align the MACHINE-GUARD System, as follows (refer to Figure 17, page 27):

- 1) Turn off power to the MACHINE-GUARD System and to the guarded machine.  
Leave power to the guarded machine "off", and power-up the MACHINE-GUARD System only.
- 2) The MACHINE-GUARD will power up into a *power-up lockout condition*. Reset the M-G System as follows:  
Turn the control box front-panel key reset switch to the RESET position,  
Leave the key in the RESET position for at least 1/2 second to allow time for internal M-G System checks, and  
Turn the key switch to the RUN position.
- 3) Upon the completion of step #2, the MACHINE-GUARD System enters either a TRIP or a CLEAR condition.  
TRIP condition: YELLOW and RED indicators (only) "on" steadily. Go to Step #4.  
CLEAR condition: YELLOW and GREEN\* indicators (only) "on" steadily. Go to step #5.
- 4) A TRIP condition after a RESET indicates that the MACHINE-GUARD receiver is not seeing the light from the emitter. If this situation occurs,
  - a) Monitor the GREEN\* indicator on the front panel of the control box. Recheck the mechanical alignment of the MACHINE-GUARD System (Section 3.3). Begin with the emitter and receiver at their desired locations. Adjust the corner mirrors (if used) so that the angle of incidence to the mirror equals the angle of reflectance from the mirror. Make sure that the emitter and receiver and all mirrors are in the same plane (use a level if necessary), and that the midpoints of all sensors and mirrors in the system (indicated by the broken line in Figure 16) are at the same level.
  - b) When the receiver sees the light from the emitter, the GREEN\* indicator on the control box panel will light\*. When the GREEN indicator comes "on", go to step #5. (At this point, the GREEN\*, and YELLOW indicators will be "on".)

\*The GREEN LED will *flash* if blanking is "on".

(continued on page 27)

Figure 16. MACHINE-GUARD System, Alignment and Trip Test

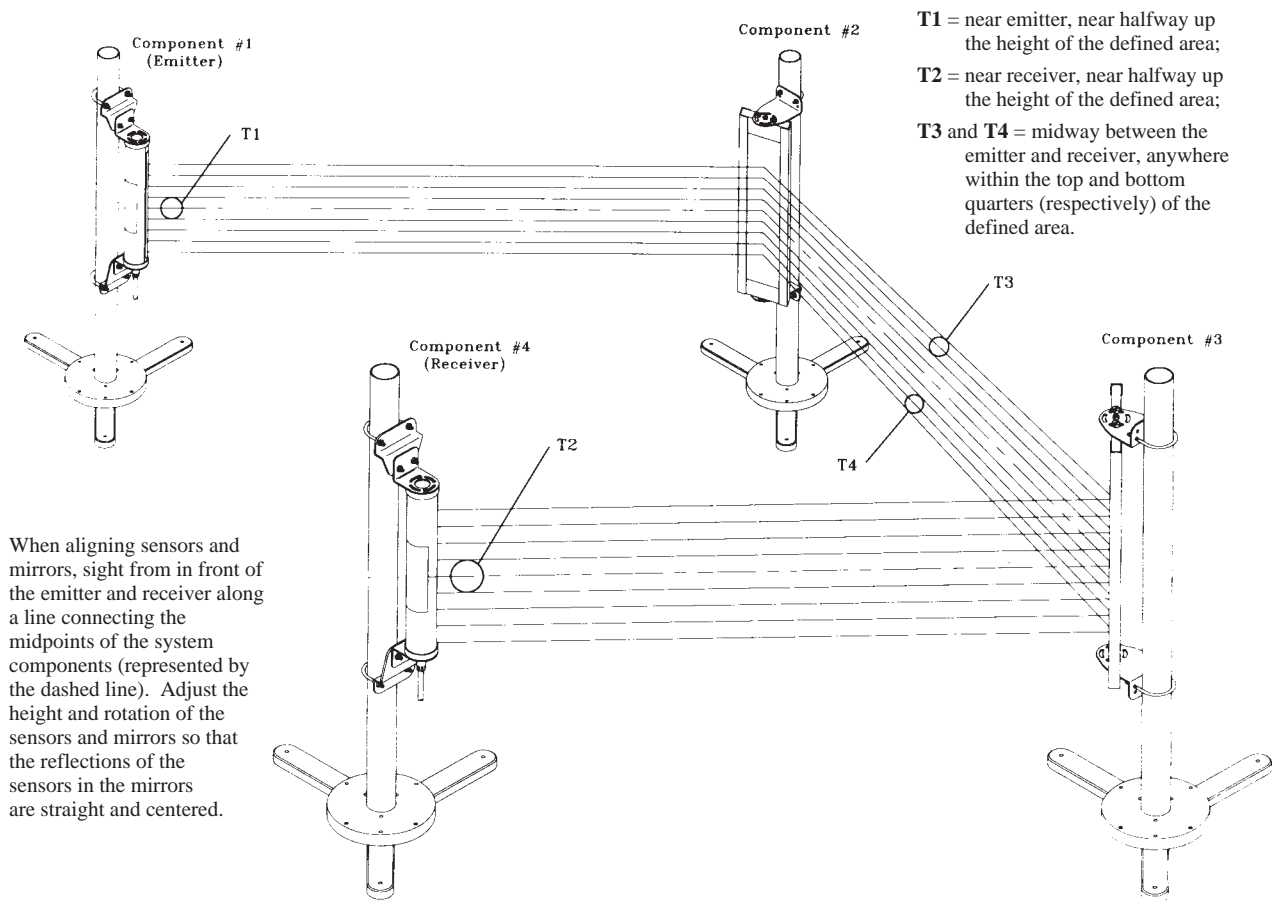

## Alignment of the MACHINE-GUARD System (continued)

- 5) If the GREEN\* indicator is "on", the receiver is seeing light from the emitter. In steps a, b, and c (below), alignment will be optimized to ensure that the MACHINE-GUARD System is operating with the maximum possible excess gain for the distances involved.
- Carefully move the emitter (or the receiver) up and down along its long axis. Find the midpoint between extremes of movement within which the GREEN indicator stays "on"\*. Temporarily secure the sensor at this point.
  - Carefully rotate the same sensor in its mounting brackets, this time looking for the midpoint between the extremes of rotation within which the GREEN indicator stays "on"\*. The careful completion of 5a and 5b constitutes optimal sensor alignment. Secure the sensor at this position. Repeat step 5b using the other sensor, and secure it in position.
  - Repeat step 5b for each mirror in the System. Secure the mirror(s) at their optimum position(s).
- 6) "Trip test" the MACHINE-GUARD System for object detection capability using the 1.5" diameter specified test piece supplied with the control box. To perform this test, the key switch must be in the RUN position and the green\* and yellow LEDs (only) must be "on". Reset the system (key reset) if necessary.

\*The GREEN LED will flash if blanking is "on".

### Perform the trip test as follows:

**If mirrors are used**, insert the specified test piece into the defined area at test location T1 (see Figure 16, page 27). The red and yellow indicators must come "on" (indicating a TRIP condition) when the test piece enters the defined area, and must go "off" when the test piece is removed from the defined area. The green indicator must go "off" when the test piece enters the defined area and go "on" when the test piece is removed from the defined area. Perform this same trip test at test locations T2, T3, and T4. Following each trip, the MACHINE-GUARD System should operate normally. **If the system contains only sensors (no mirrors)**, perform the trip test at the corresponding four locations: near the emitter, near the receiver, and at two points in the upper or lower quarter of the defined area near the midpoint between the sensors. Following each trip, the MACHINE-GUARD System should operate normally.

- 7) **If the green and yellow indicators are "on" but the MACHINE -GUARD System does not respond as described to all aspects of the trip test (step #6)**, the lack of response may be due to nearby reflective surfaces reflecting light from the emitter to the receiver via an alternate route. Move the defined area or the reflective surface (be sure to maintain at least the minimum required separation distance), or take measures to reduce the reflectivity of the interfering surface (i.e. angling, painting, masking, etc).



## WARNING

If the MACHINE-GUARD System does not respond properly to the latch test, do not attempt to use the System. If the MACHINE-GUARD does not respond properly to the latch test, it cannot be relied upon to stop dangerous machine motion when a person or object enters the defined area. Serious injury or death could result.

Figure 17. Operating Status LED Conditions

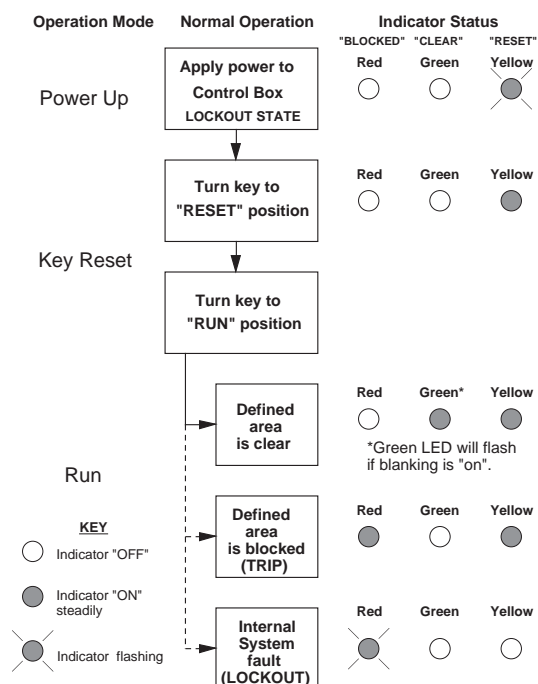

NOTE: A key RESET is always required to recover from a LOCKOUT condition.

NOTE: If the key is inadvertently turned to RESET while the system is operating normally, all three LEDs will flash. When the key is turned back to RUN, the red light will continue to flash, indicating a lockout condition. To return the system to the RUN condition, the key must again be turned to RESET, and then back to RUN.

## 6.2 Commissioning Checkout To Be Performed at Time of Installation

This commissioning checkout must be done by a *qualified person* who possesses all of the manufacturer-provided information on the MACHINE-GUARD System and guarded machine and who, by possession of a recognized degree or certificate of professional training or who, by extensive knowledge, training, or experience, has successfully demonstrated the ability to solve problems relating to the installation, operation, and maintenance of optoelectronic machine guards.

A copy of checkout results should be kept in the employer's files; see OSHA 1910.217(e)(1).

### The *qualified person* must:

- 1) Examine the guarded machine to verify that it is of a type and design that are compatible with the MACHINE-GUARD System. See page 3 for a list of misapplications.
- 2) Verify that the minimum separation distance from the closest danger point of the guarded machine to the defined area is not less than the calculated distance. See Section 3.2.1.
- 3) Verify that access to the dangerous parts of the guarded machine is not possible from any direction not protected by the MACHINE-GUARD System, hard guarding, or supplemental guarding, and verify that all supplemental guarding devices and hard guarding are in place and operating properly.
- 4) Verify that it is not possible for a person to stand between the defined area and the dangerous parts of the guarded machine.
- 5) Examine the electrical wiring connections between the MACHINE-GUARD output relays and the guarded machine's control elements to verify that the requirements stated in Section 3.5.4 are met.



**WARNING!** *A shock hazard exists while the control box door is open. Before continuing, verify that the control box door is closed and latched.*

- 6) Test the effectiveness of the MACHINE-GUARD System with power "on", as described in steps (a) through (d), below.  
**If floating blanking is in use, first block out one sensing beam as described in Section 3.5.3.**
  - a) Verify that the MACHINE-GUARD System is in the RUN mode (green\* and yellow Status Indicator LEDs "on"). See Section 4.3 for RESET procedure. \*The green Status Indicator LED will be flashing if blanking is "on".
  - b) With the guarded machine at rest, pass the 1.50-inch diameter *specified test piece* (supplied with the control box) downward through the defined area at three points: close to the receiver column, close to the emitter column, and midway between the emitter and receiver columns. In each case, the red and yellow indicators (only) should come "on" and remain "on" for as long as the test piece is within the defined area. When the test piece is withdrawn from the defined area, the green and yellow indicators (only) should come on. If the green indicator comes "on" at any time when the test piece is within the defined area, check for reflective surfaces (see Caution, page 11).
  - c) Initiate machine motion of the guarded machine and, during motion, insert the 1.50-inch diameter *specified test piece* into the defined area (at right angles to the defined area). *Do not attempt to insert the test piece into the dangerous parts of the machine.* Upon insertion of the test piece into the defined area at any time during machine motion, the dangerous parts of the machine should come to a stop with no apparent delay. Upon removal of the test piece from the defined area, verify that the machine does **not** automatically restart, and that the initiation devices must be exercised to restart the machine.
  - d) With the guarded machine at rest, insert the 1.50-inch diameter *specified test piece* into the defined area and verify that it is not possible for the guarded machine to be put into motion while the specified test piece is within the defined area.
- 7) Remove electrical power to the MACHINE-GUARD System. All output relays should immediately de-energize, and should not be capable of being reactivated until a key RESET is performed.
- 8) Test the machine stopping response time using an instrument designed for that purpose to verify that it is the same or less than the overall system response time specified by the machine manufacturer. (NOTE: Banner's Applications Engineering Department can recommend a suitable instrument.)



### WARNING

If *all* of the above checks cannot be verified, the MACHINE-GUARD System/guarded machine should not be used until the defect or problem has been corrected (see "Troubleshooting", page 22). Injury or death to personnel may result from attempts to use the guarded machine under such conditions.

## 6.3 To be Performed at Every Power-up, Shift Change, and Machine Setup Change

Daily checkout and checkouts after tooling and machine changes must be done by a *designated person* appointed and identified in writing by the employer. During continuous machine run periods, this checkout must be performed at intervals not to exceed 24 hours. A copy of checkout results should be kept on or near the machine; see OSHA 1910.217(e)(1).

### The *designated person* must:

- 1) Verify that access to the dangerous parts of the guarded machine is not possible from any direction not protected by the MACHINE-GUARD System, hard guarding, or supplemental guarding, and verify that all supplemental guarding devices and hard guarding are in place and operating properly.
- 2) Verify that the minimum separation distance from the closest danger point of the guarded machine to the defined area is not less than the calculated distance. See Section 3.2.1.
- 3) Ensure that it is not possible for a person to stand between the defined area and the dangerous parts of the guarded machine.
- 4) Verify that the MACHINE-GUARD control box is latched and locked. The key or combination to the control box latch lock should be in the possession of a *qualified person*.



**WARNING!** A shock hazard exists while the control box door is open. Before continuing, verify that the control box door is closed and latched.

- 5) Test the effectiveness of the MACHINE-GUARD System with power "on", as described in steps (a) through (d), below. **If floating blanking is in use, first block out one sensing beam as described in Section 3.5.3.**
  - a) Verify that the MACHINE-GUARD System is in the RUN mode (green\* and yellow Status Indicator LEDs "on"). See Section 4.3 for RESET procedure. \*The green Status Indicator LED will be flashing if blanking is "on".
  - b) With the guarded machine at rest, pass the 1.50-inch diameter *specified test piece* downward through the defined area at three points: close to the receiver column, close to the emitter column, and midway between the emitter and receiver columns. In each case, the red and yellow indicators (only) should come "on" and remain "on" for as long as the test piece is within the defined area. When the test piece is withdrawn from the defined area, the green and yellow indicators (only) should come on. If the green indicator comes "on" at any time when the test piece is within the defined area, check for reflective surfaces (see Caution, page 11).
  - c) Initiate machine motion of the guarded machine and, during motion, insert the 1.50-inch diameter *specified test piece* into the defined area (at right angles to the defined area). *Do not attempt to insert the test piece into the dangerous parts of the machine.* Upon insertion of the test piece into the defined area at any time during machine motion, the dangerous parts of the machine should come to a stop with no apparent delay. Upon removal of the test piece from the defined area, verify that the machine does **not** automatically restart, and that the initiation devices must be exercised to restart the machine.
  - d) With the guarded machine at rest, insert the 1.50-inch diameter *specified test piece* into the defined area and verify that it is not possible for the guarded machine to be put into motion while the specified test piece is within the defined area.
- 6) Check carefully for external signs of damage to the MACHINE-GUARD System, the guarded machine, and their electrical wiring. Any damage found should be immediately reported to management.

## 6.4 To be Performed at Six Month Intervals (Semi-annually)

This semi-annual checkout must be done by a *qualified person*. A copy of test results should be kept on or near the machine.



**WARNING!** A shock hazard exists while the control box door is open. Before continuing, verify that the control box door is closed and latched.

### The *qualified person* must:

- 1) Perform the Commissioning Checkout Procedure (Section 6.1). If any decrease in machine braking ability has occurred, make the necessary clutch/brake repairs, readjust  $D_s$  appropriately, and re-perform the checkout sequence of Section 6.1.
- 2) Examine and test the machine primary control elements (MPCs) to ensure that they are functioning correctly and are not in need of maintenance or replacement.
- 3) Inspect the guarded machine to ensure that there are no other mechanical or structural problems that would prevent the machine from stopping or assuming an otherwise safe condition when signalled to do so by the MACHINE-GUARD System.
- 4) Examine and inspect the machine controls and connections to the MACHINE-GUARD System to ensure that no modifications have been made which adversely affect the system.



**WARNING** If all of the above checks cannot be verified, the MACHINE-GUARD System/guarded machine should not be used until the defect or problem has been corrected (see "Troubleshooting", page 22). Injury or death to personnel may result from attempts to use the guarded machine under such conditions.

---

# Glossary of Terms

Terms shown in *italics* in the definitions below are themselves defined elsewhere in the glossary.

**ANSI (American National Standards Institute):** the American National Standards Institute, is an association of industry representatives which develops technical standards which include safety standards. These standards comprise a consensus from a variety of industries on good practice and design. ANSI standards relevant to application of the MACHINE-GUARD System include ANSI B11.1 (mechanical power presses), ANSI B11.2 (hydraulic power presses), and ANSI/RIA R15.06 (industrial robots and robot systems).

**Auxiliary monitor contact:** a low load capacity, non safety-related relay contact within the MACHINE-GUARD System that follows the action of output relays FSD1 and FSD2, and whose primary purpose is to communicate with a PLC.

**Control reliability:** A method of ensuring the integrity of performance of a control system. Control circuits are designed and constructed so that a single failure or fault within the system does not prevent the normal stopping action from being applied to the machine when required, or does not create unintended machine action, but does prevent initiation of successive machine action until the failure is corrected.

**Control box:** contains the circuitry (internal to the MACHINE-GUARD System) that provides the proper voltages to the system, controls the sensing units, receives and processes information from the sensing units and the safety monitoring means, and provides outputs to the *Final Switching Devices (FSD1 and FSD2)*, the *Secondary Switching Device (SSD)*, and the *Auxiliary Monitor Relay*.

**Controller module:** a removeable printed circuit board, located within the MACHINE-GUARD System control box, which contains the microprocessors and related electronic circuits.

**Defined area:** the "curtain of light" generated by the MACHINE-GUARD System. When the defined area is interrupted by an opaque object of a specified cross section, a *trip condition* results (see Figure 1).

**Designated person:** a person or persons identified and designated in writing, by the employer, as being appropriately trained and qualified to perform a specified checkout procedure.

**Diverse redundancy:** in diverse redundancy, the redundant components are of different design, and any microprocessor programs used must run from different instruction sets written by different programmers.

**Emitter:** the light-emitting component of the MACHINE-GUARD System, consisting of a row of synchronized modulated infrared LEDs. The emitter, together with the *receiver* (placed opposite), creates a "curtain of light" called the *defined area*.

**Failure to danger:** a failure which prevents or delays the output relays of the MACHINE-GUARD System from going to a *trip condition* or a *lockout condition* in response to a condition which, in normal operation, would result in their so doing.

**Final switching device (FSD):** the two output relays (FSD1 and FSD2) of the MACHINE-GUARD System which respond to an interruption of

the defined area by interrupting the circuit connecting them to the *Machine Primary Control Elements (MPCEs)* of the *guarded machine*.

**Floating blanking:** a feature that allows the MACHINE-GUARD System to be programmed to produce an intentionally disabled light beam, within the "curtain of light", which appears to move up and down ("float") in order to allow the feeding of an object through the curtain (the *defined area*) at any point along the length of the curtain without causing a *trip condition*. The MACHINE-GUARD System allows one sensing beam to be floating blanked.

**FMEA (Failure Mode and Effects Analysis):** a testing procedure by which potential failure modes in a system are analyzed to determine their results or effects on the system. Component failure modes that produce either no effect or a *lockout condition* are permitted; failures which cause an unsafe condition (a *failure to danger*) are not. Banner MACHINE-GUARD Systems are extensively FMEA tested.

**Forced-guided contacts:** relay contacts that are mechanically linked together, so that when the relay coil is energized or de-energized, all of the linked contacts move together. If one set of contacts in the relay becomes immobilized, no other contact of the same relay will be able to move. The function of forced-guided contacts is to enable the safety circuit to check the status of the relay. Forced-guided contacts are also known as "captive contacts", "locked contacts", or "safety relays". MACHINE-GUARD Systems use output relays with forced-guided contacts.

**Full-revolution devices:** a method of machine drive arranged such that, once started, the machine can only be stopped when the full cycle is complete. Examples include positive key clutches and similar mechanisms. Banner MACHINE-GUARD Systems may **not** be used with full-revolution devices.

**Guarded machine:** the machine whose point of operation is guarded by a MACHINE-GUARD System, and whose *MPCEs* and *MSCE* are connected to relays *FSD1*, *FSD2*, and *SSD* of the MACHINE-GUARD System.

**Hard guarding:** screens, bars, or other mechanical barriers that prevent a person from reaching over, under, or around the *defined area* of an installed MACHINE-GUARD System and into the *point of operation* of the *guarded machine*.

**Key reset:** a key-operated switch that is used to restore the *Final Switching Devices (FSDs)* and *Secondary Switching Device (SSD)* to the *ON state* from a *lockout condition*. Also refers to the act of using the switch to reset the MACHINE-GUARD System.

**Lockout condition:** a condition of the MACHINE-GUARD System that is automatically attained both: (1) when its ac supply mains are interrupted and restored, and (2) in response to certain failure signals. When a lockout condition occurs, the MACHINE-GUARD System's *FSD*, *SSD*, and *Auxiliary Monitor Relay* contacts open, and a *key reset* is required to return the system to the RUN condition.

**Machine primary control element (MPCE):** an electrically powered element, external to the MACHINE-GUARD System, which directly controls the machine's normal operating motion in such a way that it is last (in time) to operate when motion is either initiated or arrested.

**Machine response time:** the time between the interruption by the *Final Switching Devices (FSDs)* of the electrical supply to the *Machine Primary Control Element(s)* (MPCEs) and the instant when the dangerous parts of the machine reach a safe state by being brought to rest.

**Machine secondary control element (MSCE):** a machine control element independent of the *Machine Primary Control Element(s)* (MPCEs), capable of removing the source of power from the prime mover of the relevant dangerous machine parts.

**Minimum object sensitivity:** the minimum-diameter object that a light curtain system can reliably detect. Objects of this diameter or greater will be detected anywhere in the sensing field. A smaller object can pass undetected through the curtain of light if it passes exactly midway between two adjacent light beams. See also *specified test piece*.

**MPCE monitor contacts:** the normally open and normally closed contacts of a *guarded machine's* MPCEs which are connected in series with the ac power supply to the MACHINE-GUARD System. Any inconsistency of action between the two sets of monitor contacts will remove power from the MACHINE-GUARD System and cause a *lockout condition*. See Figure 15.

**OFF state (of Final and Secondary Switching Devices):** in the OFF state, the output circuit is broken and interrupts the flow of current.

**ON state (of Final and Secondary Switching Devices):** in the ON state, the output circuit is complete and permits the flow of current.

**OSHA (Occupational Safety and Health Administration); OSHA CFR 1910.217:** Occupational Safety and Health Administration (a US Federal agency), Division of the US Department of Labor, that is responsible for the regulation of workplace safety. OSHA regulations often follow ANSI standards, including mechanical power press requirements (OSHA CFR 1910.217). These regulations become law when adopted by OSHA, and must be followed.

**Output relays:** the devices (within the MACHINE-GUARD System) that are used to initiate an emergency stop signal. The MACHINE-GUARD System's output relays (*FSD1*, *FSD2*, and *SSD*) use *forced-guided contacts*.

**Point of operation:** the area of the *guarded machine* where a workpiece is positioned and a machine function (i.e. shearing, forming, punching, assembling, welding, etc.) is performed upon it.

**Power supply board:** a removeable printed circuit board which contains the power supply circuit and is located inside the MACHINE-GUARD System *control box*. A green LED on the power supply board lights whenever dc power is present on the board.

**PSDI (Presence Sensing Device Initiation):** an application in which a presence sensing device is used to actually start the cycle of a machine. In a typical situation, an operator manually positions a part in the machine for the operation. When the operator moves out of the danger area, the presence sensing device starts the machine (i.e. no start switch is used). The machine cycle runs to completion, and the operator can then insert a new part and start another cycle. The presence sensing device continually guards the machine. Single break mode is used when the part is

automatically ejected after the machine operation. Double break mode is used when the part is both inserted (to begin the operation) and removed (after the operation) by the operator. PSDI is defined in OSHA CFR 1910.217. *Banner MACHINE-GUARD Systems may not be used as PSDI devices on mechanical power presses, per OSHA regulation 29 CFR 1910.217.*

**Qualified person:** a person or persons who, by possession of a recognized degree or certificate of professional training, or who, by extensive knowledge, training, and experience, has successfully demonstrated the ability to solve problems relating to the subject matter and work (ANSI B30.2-1983).

**Receiver:** the light-receiving component of the MACHINE-GUARD System, consisting of a row of synchronized phototransistors. The receiver, together with the *emitter* (placed opposite), creates a "curtain of light" called the *defined area*.

**Secondary switching device (SSD):** the output relay of the MACHINE GUARD System which, in a *lock-out condition*, interrupts the circuit connecting it to the *Machine Secondary Control Element (MSCE)*.

**Self-checking (circuitry):** a circuit with the capability to electronically verify that all of its own critical circuit components, along with their redundant backups, are operating properly. Banner MACHINE-GUARD Systems are self-checking.

**Separation distance:** that distance, along the direction of approach, between the outermost position at which the appropriate test piece will just be detected and the nearest dangerous machine parts.

**Single-stroke press:** see *full-revolution devices*.

**Specified test piece:** an opaque object of the minimum cross section required to place the MACHINE-GUARD System into a *trip condition* when inserted into any part of the *defined area*. The Banner-supplied specified test piece is 1.50" in diameter. See also *minimum object sensitivity*.

**Supplemental guarding:** additional electrosensitive safety device(s), possibly employed along with *hard guarding* measures, used for the purpose of preventing a person from reaching over, under, or around the *defined area* of an installed MACHINE-GUARD System and into the *point of operation* of the *guarded machine*.

**Trip condition:** the response of the *Final Switching Device (FSD)* relays when an object equal to or greater than the diameter of the *specified test piece* enters the *defined area*. In a trip condition, FSD1 and FSD2 simultaneously de-energize and open their contacts. A trip condition clears automatically when the object is removed from the defined area.

**UL (Underwriters Laboratory):** a third party organization which tests a manufacturer's products for compliance with appropriate standards, electrical and/or safety codes. Compliance is indicated by their Listing Mark on the product.

# Standards Applicable to M-G Systems

## ANSI Standards: Standards Applicable to Use of Safety Light Curtains

### ANSI B11.1-1988

Machine Tools-  
Mechanical Power Presses-  
Safety Requirements for Construction, Care,  
and Use of

### ANSI B11.2-1982

Hydraulic Power Presses-  
Safety Requirements for Construction, Care,  
and Use of

### ANSI B11.3-1982 (R1988)

Power Press Brakes-  
Safety Requirements for Construction, Care,  
and Use of

### ANSI B11.4-1983

Shears-  
Safety Requirements for Construction, Care,  
and Use of

### ANSI B11.5-1988

Machine Tools-  
Iron Workers-  
Safety Requirements for Construction, Care,  
and Use of

### ANSI B11.6-1984

Lathes-  
Safety Requirements for Construction, Care,  
and Use of

### ANSI B11.7-1985

Cold Headers and Cold Formers-  
Safety Requirements for Construction, Care,  
and Use of

### ANSI B11.8-1983

Drilling, Milling, and Boring Machines-  
Safety Requirements for Construction, Care,  
and Use of

### ANSI B11.9-1975 (R1987)

Grinding Machines-  
Safety Requirements for Construction, Care,  
and Use of

### ANSI B11.10-1990

Metal Sawing Machines-  
Safety Requirements for Construction, Care,  
and Use of

### ANSI B11.11-1985

Gear Cutting Machines-  
Safety Requirements for Construction, Care,  
and Use of

### ANSI B11.12-1983 (R1989)

Roll Forming and Roll Bending Machines-  
Safety Requirements for Construction, Care,  
and Use of

### ANSI B11.13-1992

Machine Tools-  
Single- and Multiple-Spindle Automatic Bar  
and Chucking Machines-  
Safety Requirements for Construction, Care,  
and Use of

### ANSI B11.14-1983

Coil Slitting Machines/Systems-  
Safety Requirements for Construction, Care,  
and Use of

### ANSI B11.15-1984 (R1989)

Pipe, Tube, and Shape Bending Machines-  
Safety Requirements for Construction, Care,  
and Use of

### ANSI B11.16-1988

Metal Powder Compacting Presses-  
Safety Requirements for Construction, Care,  
and Use of

### ANSI B11.17-1982 (R1989)

Horizontal Extrusion Presses-  
Safety Requirements for Construction, Care,  
and Use of

### ANSI B11.18-1985

Machinery and Machine Systems for the  
Processing of Coiled Strip, Sheet, and Plate-  
Safety Requirements for Construction, Care,  
and Use of

### ANSI B11.19-1990

Performance Criteria for the Design,  
Construction, Care, and Operation of  
Safeguarding when Referenced by the  
Other B11 Machine Tool Safety Standards

### ANSI B11.20-1991

Machine Tools-  
Manufacturing Systems/Cells-  
Safety Requirements for Construction, Care,  
and Use of

### ANSI/RIA 15.06

Safety Requirements for Industrial Robots  
and Robot Systems

### ANSI B11 Documents

Part of:  
*Code of Federal Regulations*  
Title 29, Parts 1900 to 1910  
Address:  
*Superintendent of Documents*  
*Government Printing Office*  
Washington, DC 20402-9371  
Telephone: 202-783-3238

### ANSI/RIA Documents

Obtain from ANSI (left) or:  
*Robotic Industries Association*  
900 Victors Way, P.O. Box 3724  
Ann Arbor, MI 48106  
Telephone: 313-994-6088

## U.S. Federal Regulations Applicable to Use of Safety Light Curtains

### OSHA 29 CFR 1910.212

General Requirements for (guarding of)  
All Machines

### OSHA 29 CFR 1910.217

(Guarding of) Mechanical Power Presses

Part of:  
Code of Federal Regulations  
Title 29, Parts 1900 to 1910

Address:  
Superintendent of Documents  
Government Printing Office  
Washington, D.C.  
20402-9371  
Telephone: 202-783-3238

## Standards Applicable to Design of Safety Light Curtains

### UL 491

The Standard for Power-operated  
Machine Controls and Systems

Address:  
Underwriters Laboratories Inc.  
333 Pfingsten Road  
Northbrook, IL 60062-2096  
Telephone: 708-272-8800

### BS 6491

General Requirements for Electro-  
sensitive  
Safety Systems for Industrial Machines

Address:  
British Standards Association  
2 Park Street  
London W1A 2BS  
England  
Telephone: 011-44-908-1166



# Specifications and Model Listings

**Width of defined area:**

6 inches (15 cm) minimum. 3x excess gain at 45 feet (14 m); somewhat less when lens shields and corner mirrors are used.

**Minimum object sensitivity:**

1.50 inches (38,1 mm); assumes no floating blanking in use. See Figure 6 (page 11) for more information.

**Response time:** Less than 40 milliseconds using an emitter and receiver of up to 48 inches in length; less than 55 milliseconds using an emitter and receiver of 54 to 72 inches in length.

**Self-checking interval:** 20 milliseconds

**Ambient light immunity:** >10,000 lux at 5° angle of incidence

**Strobe light immunity:** Totally immune to one Federal Signal Corp. "Fireball" model FB2PST strobe.

**Emitter elements:** Infrared LEDs; 880nm peak emission

**Enclosures:**

**Emitter and receiver:**

Size: see Figure 13, page 18

Material: Aluminum, with black anodized finish; acrylic lens cover

Rating: NEMA 4, 13 (IP 65)

**Control box:**

Size: see Figure 13, page 18

Material: Welded steel box with black polyester powder paint finish

Rating: NEMA 13 (IP 64)

**Mounting hardware:**

Emitter and receiver are each supplied with a pair of mounting brackets. Mounting brackets are 11-gauge cold-rolled black zinc chromate finished steel. A set of four vibration dampening mounts is also supplied.

**Cables:**

*NOTE: Use only Banner cables, which incorporate a "twisted pair" for noise immunity on RS485 com lines. Use of other cables can result in "nuisance" lockouts.* Emitter and receiver cables are ordered separately. Banner 5-conductor cables have a straight QD (Quick Disconnect) connector molded onto the sensor end. Cables measure .5" in diameter, and are PVC-jacketed. Conductors are 16-gauge. Two liquid-tight cable gland/strain relief fittings are supplied with each control box to admit the emitter and receiver cables through the selected knockouts on the control box wall. The total length of the emitter and receiver cables should not exceed 175 feet. See page 34 for listing of cable models.

See page 19 for a dimension drawing of the QD-style connector.

**System power requirements:**

Control box MGCA-5A: 115V ac (50/60Hz), 50 VA;

Control box MGCB-5A: 230V ac (50/60Hz), 50 VA

**Fuse rating:**

Control box MGCA-5A: 1/2 amp, 250V ac (3AG slow blow);

Control box MGCB-5A: 1/4 amp, 250V ac (3AG slow blow)

**Status indicators (on control box):**

Red =	BLOCKED	Flashing red =	LOCKOUT
Green =	CLEAR	Flashing green =	BLANKING "on"
Yellow =	RESET	Flashing yellow =	waiting for powerup key reset

**Diagnostic indicators:**

Four LEDs indicate 6 system status conditions (see Fig. 15, page 23)

**Controls and adjustments:**

Keyed RESET of system lockout conditions  
 ARRAY LENGTH selection switches  
 BLANKING function selection switches

**Auxiliary monitor relay:** Reed relay; 125V ac or dc max., 500 mA. max. (10VA maximum, resistive load)

**Output configuration (FSD1, FSD2, and SSD):**

Forced-guided contact relays, 250V ac max., 4 amps max. (resistive load). *Mechanical life* 10,000,000 operations (minimum). *Electrical life* (at full rated load) 100,000 operations (typical). *Arc suppression is recommended when switching inductive loads.* See Figure 12, page 17.

**Operating temperature:** 0 to +50°C (+32 to 122°F)

**Relative humidity:** 95% maximum (non-condensing)

**FMEA (Failure Mode and Effects Analysis) tested:**

per requirements of BS 6491 Part 1 Section 9 and proposed first edition of UL 491 Standard, Section SA4.



Certified in compliance with **British Standard** BS6491 PARTS I & II



Listed Presence Sensing Device 10Y8 SA8959



LR 41887

## MACHINE-GUARD Sensors and Control Boxes

Emitter/receiver Models	Height of Defined Area
MGE616A emitter	6 inches (152 mm)
MGR616A receiver	
MGE1216A emitter	12 inches (305 mm)
MGR1216A receiver	
MGE1816A emitter	18 inches (457 mm)
MGR1816A receiver	
MGE2416A emitter	24 inches (610 mm)
MGR2416A receiver	
MGE3016A emitter	30 inches (762 mm)
MGR3016A receiver	
MGE3616A emitter	36 inches (914 mm)
MGR3616A receiver	
MGE4216A emitter	42 inches (1067 mm)
MGR4216A receiver	
MGE4816A emitter	48 inches (1219 mm)
MGR4816A receiver	
MGE5416A emitter	54 inches (1372 mm)
MGR5416A receiver	
MGE6016A emitter	60 inches (1524 mm)
MGR6016A receiver	
MGE6616A emitter	66 inches (1676 mm)
MGR6616A receiver	
MGE7216A emitter	72 inches (1829 mm)
MGR7216A receiver	

MGCA-5A 115V ac control box (one per system)

MGCB-5A 230V ac control box (one per system)

**Cables** One cable per sensor, 2 required per system. Total length of emitter and receiver cables should not exceed 175 feet. See *Cables*, page 34.

# Components and Accessories

## for MACHINE-GUARD Systems

### MACHINE-GUARD System

Emitter/receiver Models	Height of Defined Area
MGE616A emitter MGR616A receiver	6 inches (152 mm)
MGE1216A emitter MGR1216A receiver	12 inches (305 mm)
MGE1816A emitter MGR1816A receiver	18 inches (457 mm)
MGE2416A emitter MGR2416A receiver	24 inches (610 mm)
MGE3016A emitter MGR3016A receiver	30 inches (762 mm)
MGE3616A emitter MGR3616A receiver	36 inches (914 mm)
MGE4216A emitter MGR4216A receiver	42 inches (1067 mm)
MGE4816A emitter MGR4816A receiver	48 inches (1219 mm)
MGE5416A emitter MGR5416A receiver	54 inches (1372 mm)
MGE6016A emitter MGR6016A receiver	60 inches (1524 mm)
MGE6616A emitter MGR6616A receiver	66 inches (1676 mm)
MGE7216A emitter MGR7216A receiver	72 inches (1829 mm)
MGCA-5A 115V ac control box (one per system)	
MGCB-5A 230V ac control box (one per system)	

### Cables (2 required per system)

<b>QDC-525</b>	25' cable, straight QD connector. One cable per sensor.
<b>QDC-550</b>	50' cable, straight QD connector. One cable per sensor.
<b>QDC-5100</b>	100' cable, straight QD connector. One cable per sensor.
<b>QDC-5150</b>	150' cable, straight QD connector. One cable per sensor.

**NOTE: The total length of the emitter/receiver cables may not exceed 175 feet.**

### Instruction Manual

For MGCA-5A and MGCB-5A Systems,  
order manual 33131F5D.

### Corner Mirrors & Stands

Mirror Model*	Use with Sensors	Height of Reflective Area
MGM6A	MGE/MGR616A	12 inches (305 millimeters)
MGM12A	MGE/MGR1216A	18 inches (457 millimeters)
MGM18A	MGE/MGR1816A	24 inches (610 millimeters)
MGM24A	MGE/MGR2416A	30 inches (762 millimeters)
MGM30A	MGE/MGR3016A	36 inches (914 millimeters)
MGM36A	MGE/MGR3616A	42 inches (1067 millimeters)
MGM42A	MGE/MGR4216A	48 inches (1219 millimeters)
MGM48A	MGE/MGR4816A	54 inches (1372 millimeters)
MGM54A	MGE/MGR5416A	60 inches (1524 millimeters)
MGM60A	MGE/MGR6016A	66 inches (1676 millimeters)
MGM66A	MGE/MGR6616A	72 inches (1829 millimeters)
MGM72A	MGE/MGR7216A	78 inches (1981 millimeters)

*MG Series Corner Mirror  
(2 brackets included)*

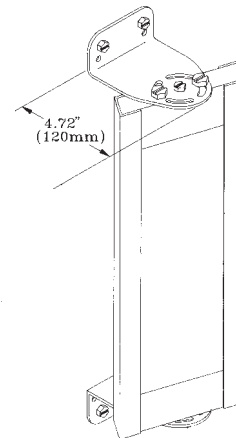

\*Mirrors are glass. Acrylic mirrors are also available (by special order). Acrylic mirrors have slightly lower reflectance than glass.

**MGA-S72-1** Free-standing 72" tall aluminum stand pole & base (recommended for sensors and mirrors up to 48" models).

**MGA-S90-1** Free-standing 90" tall aluminum stand pole & base (recommended for sensors and mirrors up to 72" models).

Each pole supports one mirror or sensor. See photo below.



*MGA Series Stand Pole  
(hardware and post level included)*

# Accessories

## for MACHINE-GUARD Systems

### Replacement Parts

27850	MGA-GS-1	ground strap, control box door
28513	MGA-K-1	replacement key
28509	MGA-KS-1	key switch
28508	MGA-LP-1	LED display, control box door
28506	MGA-MH-1	control box mounting hardware
28510	MGA-RC-1	ribbon cable
33629	MGA-RMFSD	FSD relay module
33630	MGA-RMSSD	SSD relay module
28518	MGA-STP-1	specified test piece
30700	MGAB-5	microprocessor control module*
30697	PGA-PSA-1	power supply, 115V ac
30696	PGA-PSB-1	power supply, 230V ac

\*NOTE: When ordering a replacement receiver or a replacement microprocessor control module, please supply the serial number of your present receiver and control module. This information is necessary to ensure system compatibility of the replacement item. If necessary, contact the factory applications department for ordering assistance.

### Accessories: lens shield kits

These are replaceable protective covers for MACHINE-GUARD and PERIMETER-GUARD Sensors. They are constructed of clear LEXAN® polycarbonate, and are supplied with corrosion-protected steel retaining clips. Shields may be quickly installed or removed without disturbing sensor alignment. Use of these shields results in somewhat reduced sensing range. Contact the factory for more information.

<b>MGS6A</b>	Shield kit for 6" sensor
<b>MGS12A</b>	Shield kit for 12" sensor
<b>MGS18A</b>	Shield kit for 18" sensor
<b>MGS24A</b>	Shield kit for 24" sensor
<b>MGS30A</b>	Shield kit for 30" sensor
<b>MGS36A</b>	Shield kit for 36" sensor
<b>MGS42A</b>	Shield kit for 42" sensor
<b>MGS48A</b>	Shield kit for 48" sensor
<b>MGS54A</b>	Shield kit for 54" sensor
<b>MGS60A</b>	Shield kit for 60" sensor
<b>MGS66A</b>	Shield kit for 66" sensor
<b>MGS72A</b>	Shield kit for 72" sensor

### Remote Displays (photo below)

<b>MGA-LR-1</b>	LED remote display
<b>MGA-LRKS-1</b>	LED remote display with key switch

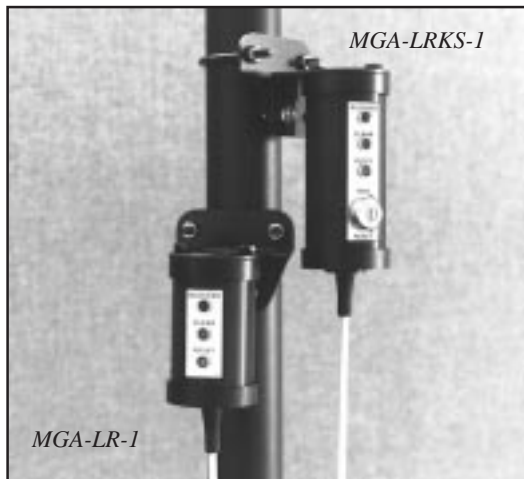

### Spanish Language Documentation

For systems using the MGCA-5A control box:  
Order p/n 39046 for manual, checkout cards, and product labels.  
Order p/n 38952 for product labels only.

For systems using the MGCB-5A control box:  
Order p/n 39047 for manual, checkout cards, and product labels.  
Order p/n 38953 for product labels only.

### Documentación en español

Para sistemas que utilicen la caja de control MGCA-5A:  
Pedir el número de pieza 39046 para recibir el manual, las tarjetas de verificación y las etiquetas del producto.  
Pedir el número de pieza 38952 para recibir las etiquetas del producto solamente.

Para sistemas que utilicen la caja de control MGCB-5A:  
Pedir el número de pieza 39047 para recibir el manual, las tarjetas de verificación y las etiquetas del producto.  
Pedir el número de pieza 38953 para recibir las etiquetas del producto solamente.

**Warranty:** Banner Engineering Corporation warrants its products to be free from defects for a period of one year. Banner Engineering Corporation will repair or replace, free of charge, any product of its manufacture found to be defective at the time it is returned to the factory during the warranty period. This warranty is necessarily limited to the quality of materials and workmanship in MACHINE-GUARD Systems as they are supplied to the original purchaser. Proper installation, operation, and maintenance of the MACHINE-GUARD System becomes the responsibility of the user upon receipt of the system. This warranty does not cover damage or liability for the improper application of the MACHINE-GUARD System. This warranty is in lieu of any other warranty either expressed or implied.

**If it ever becomes necessary to return any MACHINE-GUARD component to the factory, pack it carefully:**

- Remove the controller module from the control box, and pack the module separately, and
- Use the original packing materials whenever possible.

*Damage that occurs in return shipping is not covered by warranty.*

