

## Features

The Sure Cross® wireless system is a radio frequency network with integrated I/O that operates in most environments to eliminate the need for wiring runs. Wireless MultiHop data radio networks are formed around a MultiHop client and one or more servers and extend the range of a Modbus or other serial communication network.

- Wireless industrial I/O device with two NPN discrete inputs, two NMOS discrete outputs, two 0 to 20 mA analog inputs, one thermistor input, two SDI-12 inputs, and two switch power outputs
- Selectable transmit power levels of 250 mW or 500 mW for 900 MHz models and 65 mW for 2.4 GHz models
- *FlexPower*® power options allow for 10 V DC to 30 V DC, solar, and battery power sources for low-power applications.
- Self-healing, auto-routing radio frequency network with multiple hops extends the network's range and improves radio link performance
- Serial and I/O communication on a Modbus platform
- Message routing improves link performance
- DIP switches select operational modes: client, repeater, or server
- Built-in site survey mode enables rapid assessment of a location's RF transmission properties
- Frequency Hopping Spread Spectrum (FHSS) technology ensures reliable data delivery



## Models

Model	ISM Radio Band	Supply Voltage	Housing	Inputs and Outputs
<b>DX80DR9M-H12E</b>	900 MHz	10 to 30 V DC or integrated battery	IEC IP65; NEMA 4X	<b>Inputs:</b> Two NPN discrete, two 0 to 20 analog, one thermistor, and two SDI-12 <b>Outputs:</b> Two NMOS discrete <b>Switch Power:</b> Two (for SDI-12) <b>Serial interface:</b> RS-485

The following models are no longer available for order but are covered by the contents of this document: DX80DR9M-H12, DX80DR2M-H12, and DX80DR2M-H12E

## Configuration Instructions

### Set Up Your MultiHop Network

To set up and install your wireless MultiHop network, follow these steps:

1. If your radios have DIP switches, configure the DIP switches of all devices.
2. Connect the sensors to the MultiHop radios if applicable.
3. Apply power to all devices.
4. If your MultiHop radio has rotary dials, set the MultiHop Radio ID. If your MultiHop radio has no rotary dials, continue to the next step.
5. Form the wireless network by binding the server and repeater radios to the client radio. If the binding instructions are not included in this datasheet, refer to the quick start guide or product manual.
6. Observe the LED behavior to verify the devices are communicating with each other.
7. Configure any I/O points to use the sensors connected to the Sure Cross devices.
8. Conduct a site survey between the MultiHop radios. If the site survey instructions are not included in this datasheet, refer to the product manual.
9. Install your wireless sensor network components. If the installation instructions are not included in this datasheet, refer to the product manual.

For additional information, refer to one of the following documents:

- MultiHop Data Radio Quick Start Guide: [152653](#)
- MultiHop Data Radio Instruction Manual: [151317](#)
- MultiHop Register Guide: [155289](#)

### Configure the DIP Switches

Before changing DIP switch positions, disconnect the power.<sup>(1)</sup>

<sup>(1)</sup> For devices powered by batteries integrated into the housing, triple-click button 2, then double-click button 2 to reset the device without removing the battery.

Any changes made to the DIP switches are not recognized until after power is cycled to the device. For parameters not set using the DIP switches, use the configuration software to make configuration changes. For parameters set using the DIP switches, the DIP switch positions override any changes made using the configuration software.

## Access the Internal DIP Switches

Follow these steps to access the internal DIP switches.

1. Unscrew the four screws that mount the cover to the bottom housing.
2. Remove the cover from the housing without damaging the ribbon cable or the pins the cable plugs into.
3. Gently unplug the ribbon cable from the board mounted into the bottom housing. Skip this step if there is no ribbon cable (integrated battery models) or the ribbon cable is glued down (for C housing models).
4. Remove the black cover plate from the bottom of the device's cover.  
The DIP switches are located behind the rotary dials.
5. Make the necessary changes to the DIP switches.
6. Place the black cover plate back into position and gently push into place.
7. If necessary, plug the ribbon cable in after verifying that the blocked hole lines up with the missing pin.
8. Mount the cover back onto the housing.

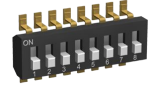

## DIP Switch Settings (MultiHop)

Device Settings	Switches							
	1	2	3	4	5	6	7	8
Serial line baud rate 19200 OR User defined receiver slots	OFF <sup>1</sup>	OFF <sup>1</sup>						
Serial line baud rate 38400 OR 32 receiver slots	OFF	ON						
Serial line baud rate 9600 OR 128 receiver slots	ON	OFF						
Serial line baud rate Custom OR 4 receiver slots	ON <sup>2</sup>	ON <sup>2</sup>						
Parity: None			OFF <sup>1</sup>	OFF <sup>1</sup>				
Parity: Even			OFF	ON				
Parity: Odd			ON	OFF				
Disable serial (low power mode) and enable the receiver slots select for switches 1-2			ON <sup>2</sup>	ON <sup>2</sup>				
Transmit power 900 MHz radios: 500 mW (27 dBm) 2.4 GHz radios: 65 mW (18 dBm) and 60 ms frame					OFF <sup>1</sup>			
Transmit power 900 MHz radios: 250 mW (24 dBm) 2.4 GHz radios: 65 mW (18 dBm) and 40 ms frame					ON			
Application mode: Modbus						OFF <sup>1</sup>		
Application mode: Transparent						ON		
MultiHop radio setting: Repeater							OFF <sup>1</sup>	OFF <sup>1</sup>
MultiHop radio setting: Client							OFF	ON
MultiHop radio setting: Server							ON <sup>2</sup>	OFF <sup>2</sup>
MultiHop radio setting: Reserved							ON	ON

<sup>1</sup> Default configuration

<sup>2</sup> Default configuration for the E housing models only

## Application Mode

The MultiHop radio operates in either Modbus mode or transparent mode. Use the internal DIP switches to select the mode of operation. All MultiHop radios within a wireless network must be in the same mode.

**Modbus** mode uses the Modbus protocol for routing packets. In Modbus mode, a routing table is stored in each parent device to optimize the radio traffic. This allows for point-to-point communication in a multiple data radio network and acknowledgment/retry of radio packets. To access a radio's I/O, the radios must be running in Modbus mode.

In **transparent** application mode, all incoming packets are stored, then broadcast to all connected data radios. The data communication is packet-based and not specific to any protocol. The application layer is responsible for data integrity. For one-to-one data radios it is possible to enable broadcast acknowledgment of the data packets to provide better throughput. In transparent mode, there is no access to the radio's I/O.

## Baud Rate and Parity

The baud rate (bits per second) is the data transmission rate between the device and whatever it is physically wired to. Set the parity to match the parity of the device you are wired to.

## Disable Serial

Disable an unused local serial connection to reduce the power consumption of a data radio powered from the solar assembly or from batteries. All radio communications remain operational.

## Receiver Slots

The number of receiver slots indicates the number of times out of 128 slots/frames the radio can transmit to its parent radio. Setting a server's receiver slots to four reduces the total power consumption by establishing that the server can only transmit to its parent four times per 128 slots.

## Transmit Power Levels/Frame Size

The 900 MHz data radios can be operated at 500 mW (27 dBm) or 250 mW (24 dBm). For most models, the default transmit power is 500 mW.

For 2.4 GHz radios, the transmit power is fixed at 65 mW (18 dBm) and DIP switch 5 is used to set the frame timing. The default position (OFF) sets the frame timing to 60 milliseconds. To increase throughput, set the frame timing to 40 milliseconds. For battery-powered devices, increasing the throughput decreases battery life.

## Wire Your Sure Cross Device

Use the following wiring diagrams to first wire the sensors and then apply power to the Sure Cross® devices.

## M-H12 Terminal Blocks and Wiring

Connecting power to the communication pins will cause permanent damage.

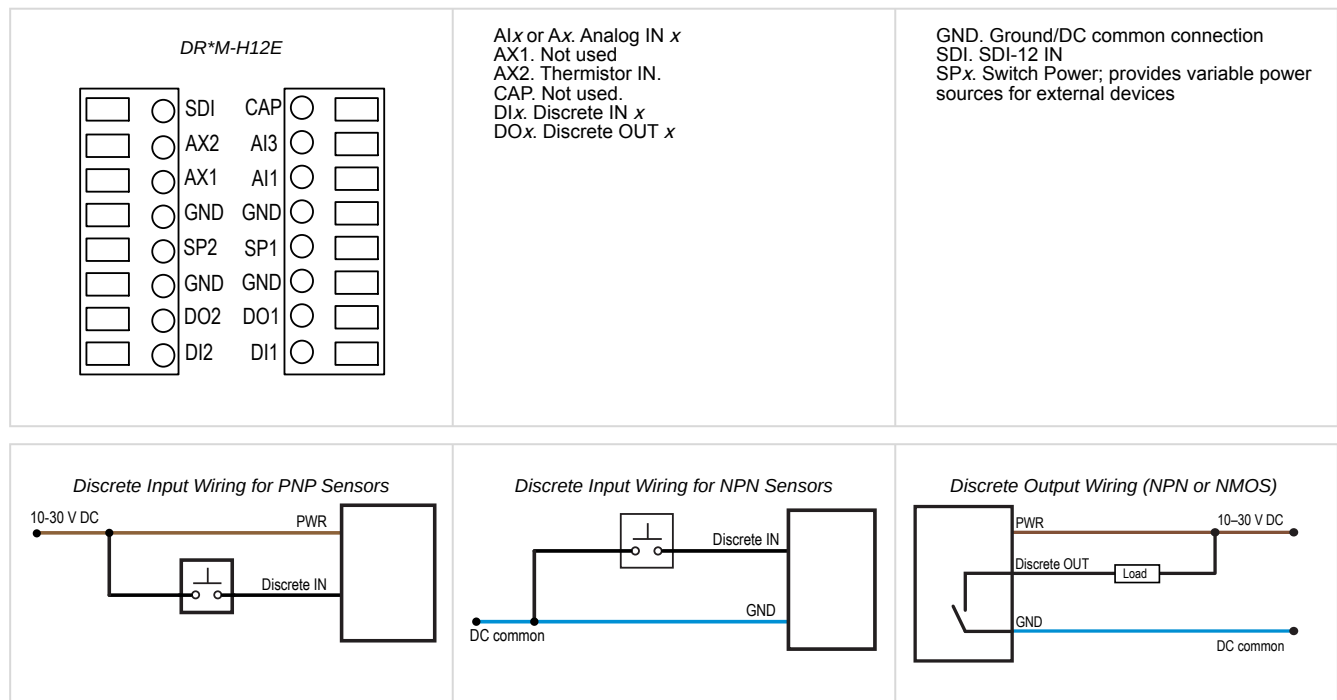

Continued on page 4

Continued from page 3

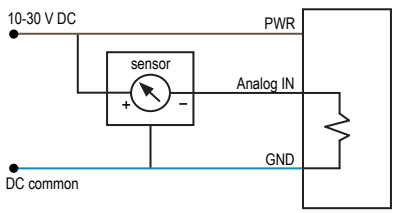
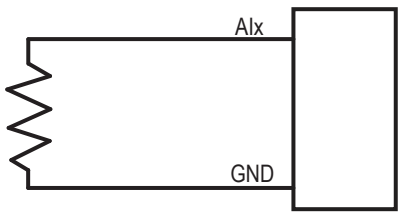
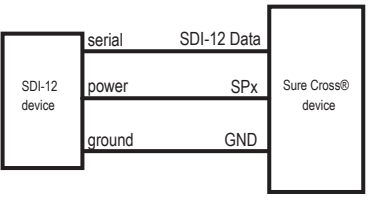
<p><i>Analog Input Wiring (10–30 V DC Power)</i></p> 	<p><i>Thermistor Input</i></p> 	<p><i>Input Wiring for SDI-12 Sensors</i></p> 
<p>Do not exceed analog input ratings for analog inputs. Only connect sensor outputs to analog inputs.</p>	<p>Wire the thermistor for the M-H12 model to AX2. Wire the thermistor for the M-H12C model to AX1.</p>	

### Apply Power to the DX80...E Radios

Connecting power to the communication pins will cause permanent damage. The integrated battery DX80...E radios may also be powered by 10 V DC to 30 V DC. The power for the sensors can be supplied by the radio's SPx terminals or from the 10 V DC to 30 V DC used to power the radio. The BAT connection is a low voltage connection to the internal battery. Remove the internal battery if a low voltage source is connected to the BAT terminal. When powering the device from the integrated battery, the BAT connection must remain open.

	<b>Integrated battery (RS-485) for P1E, M-H1E, M-H12E, and P16E Models</b>	<b>Integrated battery (RS-232) for P3E, P4E, M-H3E, and M-H4E Models</b>
	1	10 V DC to 30 V DC (optional)
	2	RS-485 / D1 / B / +
	3	DC common (GND)
	4	RS-485 / D0 / A / -

### Set the MultiHop Radio ID

The Modbus ID is an identifying number used for devices within a Modbus system. When using more than one Modbus peripheral, assign each peripheral device a unique ID number.

For MultiHop radios with rotary dials, use the rotary dials to set the device's MultiHop Radio ID. The left dial sets the left digit and the right dial sets the right digit.

- Modbus IDs 01 through 10—Reserved for servers directly connected to the host (local I/O). Polling messages addressed to these devices are not relayed over the wireless link.
- Modbus IDs 11 through 60—Use for MultiHop client, repeater, and server radios. Up to 50 devices (local servers and remote servers) may be used in this system.

If your MultiHop radio does not have rotary dials, you must use the client radio to set the Modbus ID during the binding process.

# MultiHop Configuration Software

Use Banner's MultiHop Configuration Software to view your MultiHop radio network and configure the radio and its I/O.

MultiHop Configuration Software Network and Device Overview screen

Name	Role	Modbus Address	Device Address	Parent Address	Signal Strength	Green	Yellow	Red	Misses	Serial Number	Model Number	Build Date	RF FW PN	RF EE PN	RF PN	LCD FW PN	LCD EE PN	LCD Ver		
Master 900MHz HES	Master	1	23846	23846	0	0	0	0	0	154918	186215	001544	175068	3.6C	157270	1.0				
DATA RADIO DEVICE	Slave	35	34520	23846	50	0	0	0	0	100056	000000	000000	165062	3.0E	159481	0.2A				
DATA RADIO DEVICE	Slave	17	24200	23846	0	0	0	0	0	155272	151687	001544	166893	3.4	157271	1.1				
MultiHop Data Radio	Slave	14	64179	23846	0	0	0	0	0	195251	157568	001233	157719	2.2	157272	1.0				
DATA RADIO DEVICE	Slave	45	63129	23846	0	0	0	0	0	259737	151687	001415	166893	2.6	157271	1.1				
DATA RADIO DEVICE	Slave	19	24203	23846	0	0	0	0	0	155275	151687	001544	166893	3.4	157271	1.1				
DATA RADIO DEVICE	Slave	90	4775	23846	0	0	0	0	0	135847	183420	001523	166893	2.6	157271	1.1				
MultiHop Data Radio	Slave	15	64180	23846	0	0	0	0	0	195252	157598	001233	157719	2.2	157272	1.0				
DATA RADIO DEVICE	Slave	37	56005	23846	0	0	0	0	0	842437	190055	1541	169345	3.1	169449	0.1C				
MultiHop Data Radio	Slave	16	64154	23846	0	0	0	0	0	195256	157568	001233	157719	2.2	157272	1.0				
DATA RADIO DEVICE	Slave	20	24196	23846	0	0	0	0	0	155268	151687	001544	166893	3.4	157271	1.1				
DATA RADIO DEVICE	Slave	36	56006	23846	0	0	0	0	0	842438	190055	1541	169345	3.1	169449	0.1C				
MH MPage SID 13	Slave	13	64176	23846	0	0	0	0	0	195248	157598	001233	157719	2.2	157272	1.0				
DATA RADIO DEVICE	Slave	18	24202	23846	0	0	0	0	0	155274	151687	001544	166893	3.4	157271	1.1				
DATA RADIO DEVICE	Slave	27	9819	23846	0	0	0	0	0	271963	151687	001425	166893	2.6	157271	1.1				
MultiHop Radio H12	Repeater	91	58281	23846	78	70	0	0	22	123817	151685	1512	148691	2.2	151698	1.3	136499	3.2	148880	1.0
DATA RADIO DEVICE	Slave	84	4794	58281	0	0	0	0	0	135866	183420	001523	166893	2.6	157271	1.1				
DATA RADIO DEVICE	Slave	32	9821	58281	0	0	0	0	0	271965	151687	001425	166893	2.6	157271	1.1				
MH MPage SID 12	Slave	12	64185	58281	0	0	0	0	0	195257	157598	001233	157719	2.2	157272	1.0				
MultiHop Data Radio	Slave	78	29005	58281	0	0	0	0	0				166893	2.6	157272	1.1				
DATA RADIO DEVICE	Slave	31	65198	58281	0	0	0	0	0	261806	151687	001417	166893	2.6	157271	1.1				
DATA RADIO DEVICE	Slave	82	4744	58281	0	0	0	0	0	135816	183420	001523	166893	2.6	157271	1.1				
MH MPage SID 11	Slave	11	64181	58281	0	0	0	0	0	195253	157598	001233	157719	2.2	157272	1.0				
DATA RADIO DEVICE	Slave	83	4743	58281	0	0	0	0	0	135815	183420	001523	166893	2.6	157271	1.1				

The software connects to a MultiHop client radio using one of four methods.

- Serial; using a USB to RS-485 (for RS-485 radios) or a USB to RS-232 (for RS-232 radios) converter cable.
- Modbus TCP; using an Ethernet connection to an Ethernet radio client.
- Serial DXM; using a USB cable to a DXM Controller to access a MultiHop client radio.
- TCP DXM; using an Ethernet connection to a DXM Controller to access a MultiHop client radio.

Banner recommends using **BWA-UCT-900**, an RS-485 to USB adapter cable with a wall plug that can power your radio while you configure it. The adapter cable is not required when connecting to a DXM Controller.

Download the most recent software revision from the Wireless Reference Library on Banner Engineering's website:  
[www.bannerengineering.com](http://www.bannerengineering.com).

## Configure the SDI-12 Inputs

The SDI-12 interface on the MultiHop radio can support up to five devices with (12) 32-bit register values each. The radio's SDI-12 interface can be configured to increase the number of registers per device address for devices with large register sets. The factory default enables one SDI-12 device using device address 1 with up to nine registers with a SDI-12 command of "M!".

Configure the MultiHop device by writing to non-volatile Modbus registers with configuration parameters. Read or write the device configuration parameters using standard Modbus commands. For more information about manually configuring the SDI-12 interface, refer to the MultiHop Register Parameter document, p/n 155289.

## Basic SDI-12 Interface Parameters

Up to five devices/commands can be accessed using the SDI-12 interface. There are three parameters for each device/command: Enable, Device Address, Device Command. For more information, refer to the SDI-12 Technical Notes.

**Enable.** Instructs the MultiHop H12 device to activate or deactivate the SDI-12 device. Write a 1 to enable, and write a 0 to disable. The factory default for device 1 is enabled; devices 2 through 5 are disabled.

**Device Address.** Each SDI-12 device must have a unique device address. This parameter is the ASCII code for the device address. Valid device addresses are 0-9 and a-z that map to ASCII codes 48-57 and 97-122, respectively. The factory default addresses are:

- SDI-12 Device 0 uses ASCII code 48
- SDI-12 Device 1 uses ASCII code 49
- SDI-12 Device 2 uses ASCII code 50
- SDI-12 Device 3 uses ASCII code 51
- SDI-12 Device 4 uses ASCII code 52

**Device Command** The SDI-12 interface supports "M!" or "C!" commands. Use the Device Command parameter to define which command to use for this device. The factory default is "M!" commands for all devices (value of 10 in the Modbus register).

Supported M! commands

SDI-12 Command	Register Value	SDI-12 Command	Register Value
xM!	0 or 10	xM5!	15

Continued on page 6

Continued from page 5

SDI-12 Command	Register Value	SDI-12 Command	Register Value
xM1!	11	xM6!	16
xM2!	12	xM7!	17
xM3!	13	xM8!	18
xM4!	14	xM9!	19

*Supported C! commands*

SDI-12 Command	Register Value	SDI-12 Command	Register Value
xC!	1 or 20	xC5!	25
xC1!	21	xC6!	26
xC2!	22	xC7!	27
xC3!	23	xC8!	28
xC4!	24	xC9!	29

The Modbus configuration registers are listed. All registers are defined as Modbus holding registers. The factory default values are shown in parentheses. All values are in decimal unless noted otherwise.

Device/CMD Configuration	Registers (Default Value)		
	Enable	Device Address	Device Command
SDI-12 Device/CMD 1	1751 (1)	11001 (48) <sup>(1)</sup>	11002 (10)
SDI-12 Device/CMD 2	1701 (0)	11201 (49)	11202 (10)
SDI-12 Device/CMD 3	1651 (0)	11401 (50)	11402 (10)
SDI-12 Device/CMD 4	1601 (0)	11601 (51)	11602 (10)
SDI-12 Device/CMD 5	1551 (0)	11801 (52)	11802 (10)

## SDI-12 Device Result Registers

The result registers store all information received from the SDI-12 devices.

The registers are 16-bit registers and require two registers to store a 32-bit value. The factory default configuration defines the result registers as 32-bit registers, floating point format, and the first nine result registers are enabled for use. A host system reads the SDI-12 device data from these registers.

Result Registers	Register 1	Register 2	Register 3	Register 4	Register 5	Register 6
SDI-12 Device/CMD 1 Result Upper	11101	11103	11105	11107	11109	11111
SDI-12 Device/CMD 1 Result Lower	11102	11104	11106	11108	11110	11112
SDI-12 Device/CMD 2 Result Upper	11301	11303	11305	11307	11309	11311
SDI-12 Device/CMD 2 Result Lower	11302	11304	11306	11308	11310	11312
SDI-12 Device/CMD 3 Result Upper	11501	11503	11505	11507	11509	11511
SDI-12 Device/CMD 3 Result Lower	11502	11504	11506	11508	11510	11512
SDI-12 Device/CMD 4 Result Upper	11701	11703	11705	11707	11709	11711
SDI-12 Device/CMD 4 Result Lower	11702	11704	11706	11708	11710	11712
SDI-12 Device/CMD 5 Result Upper	11901	11903	11905	11907	11909	11911
SDI-12 Device/CMD 5 Result Lower	11902	11904	11906	11908	11910	11912

Result Registers	Register 7	Register 8	Register 9	Register 10	Register 11	Register 12
SDI-12 Device/CMD 1 Result Upper	11113	11115	11117	11119	11121	11123
SDI-12 Device/CMD 1 Result Lower	11114	11116	11118	11120	11122	11124
SDI-12 Device/CMD 2 Result Upper	11313	11315	11317	11319	11321	11323
SDI-12 Device/CMD 2 Result Lower	11314	11316	11318	11320	11322	11324
SDI-12 Device/CMD 3 Result Upper	11513	11515	11517	11519	11521	11523

Continued on page 7

<sup>(1)</sup> The default device addresses 48 through 52 are in ASCII.

Continued from page 6

Result Registers	Register 7	Register 8	Register 9	Register 10	Register 11	Register 12
SDI-12 Device/CMD 3 Result Lower	11514	11516	11518	11520	11522	11524
SDI-12 Device/CMD 4 Result Upper	11713	11715	11717	11719	11721	11723
SDI-12 Device/CMD 4 Result Lower	11714	11716	11718	11720	11722	11724
SDI-12 Device/CMD 5 Result Upper	11913	11915	11917	11919	11921	11923
SDI-12 Device/CMD 5 Result Lower	11914	11916	11918	11920	11922	11924

## SDI-12 Device Settings

Device / Cmd Configuration	Registers (Default Value)							
	Enable	Device Address	Switch Power Enable	Device Command	Sample HI	Sample Low	Warmup Time	Voltage
SDI-12 Device/CMD 1	1751 (1)	11001 (48) <sup>(1)</sup>	1754 (4)	11002 (10)	1752 (1)	1753 (24464)	1755 (200)	1756 (148)
SDI-12 Device/CMD 2	1701 (0)	11201 (49)	1704 (4)	11202 (10)	1702 (1)	1703 (24464)	1705 (200)	1706 (148)
SDI-12 Device/CMD 3	1651 (0)	11401 (50)	1654 (4)	11402 (10)	1652 (1)	1653 (24464)	1655 (200)	1656 (148)
SDI-12 Device/CMD 4	1601 (0)	11601 (51)	1604 (4)	11602 (10)	1602 (1)	1603 (24464)	1605 (200)	1606 (148)
SDI-12 Device/CMD 5	1551 (0)	11801 (52)	1554 (4)	11802 (10)	1552 (1)	1553 (24464)	1555 (200)	1556 (148)

These SDI-12 probes have been tested and are functional with the factory default settings.

MFG	Models	Technical Note
Acclima	SEN-SDI (TDT SDI-12 Soil Moisture Sensor)	<a href="#">SDI-12 and the Acclima TDT SDI-12 Soil Moisture Probe</a> (p/n b_4182040)
Adcon Telemetry	HydraProbell	
AquaCheck	Sub-surface Probe	<a href="#">SDI-12 and the AquaCheck Sub-Surface Soil Moisture Probe</a> (p/n b_4182041)
Decagon	MPS-2, MPS-6, 5TE, TS1, T8	<a href="#">SDI-12 and the Decagon 5TE Soil Moisture Probe</a> (p/n b_4182042)
		<a href="#">SDI-12 and the Decagon GS3 Soil Moisture Probe</a> (p/n b_4182043)
HSTI	HydraScout	<a href="#">SDI-12 and the Decagon MPS-2 Soil Moisture Probe</a> (p/n b_4182044)
		<a href="#">SDI-12 and the HydraScout HSTI Probe</a> (p/n b_4182045)
Sentek	EnviroSCAN	<a href="#">SDI-12 and the Sentek EnviroScan Soil Moisture Probe</a> (p/n b_4182046)

## Installing Your Sure Cross® Radios

Please refer to one of these instruction manuals to install your wireless network components.

- DX80 Performance Wireless I/O Network Instruction Manual: [132607](#)
- MultiHop Data Radio Instruction Manual: [151317](#)

## M-H12 Modbus Registers

Register (4xxxx)	Input #	Inputs	Units	I/O Range		Holding Register Representation		Terminal Block Labels
				Min. Value	Max. Value	Min. (Dec.)	Max. (Dec.)	
1	1	Discrete IN 1	-	0	1	0	1	DI1
2	2	Discrete IN 2	-	0	1	0	1	DI2
	...							
5	5	Analog IN 1 *	mA	0.0	20.0	0	65535	AI1
6	6							
7	7	Analog IN 2 *	mA	0.0	20.0	0	65535	AI3
8	8	Thermistor *	°F	-1638.3	1638.4	-32768	32767	AXx <sup>(2)</sup>
9	9							
10	10							
11	11							

Continued on page 8

<sup>(1)</sup> The default device addresses 48 through 52 are in ASCII.  
<sup>(2)</sup> Using AX2 for the M-H12 models and AX1 for the M-H12C models.

Continued from page 7

Register (4xxx)	Input #	Inputs	Units	I/O Range		Holding Register Representation		Terminal Block Labels
				Min. Value	Max. Value	Min. (Dec.)	Max. (Dec.)	
12	12	SDI-12 Device/CMD 5 *						SDI
13	13	SDI-12 Device/CMD 4 *						SDI
14	14	SDI-12 Device/CMD 3 *						SDI
15	15	SDI-12 Device/CMD 2 *						SDI
16	16	SDI-12 Device/CMD 1						SDI

\* The factory default setting for SDI-12 devices 2 through 5, analog inputs 1 and 2, and the thermistor are disabled.

Register (4xxx)	Output #	Outputs	Units	I/O Range		Holding Register Representation		Terminal Block Labels
				Min. Value	Max. Value	Min. (Dec.)	Max. (Dec.)	
501	1	Discrete OUT 1	-	0	1	0	1	DO1
502	2	Discrete OUT 2	-	0	1	0	1	DO2
503	3	Switch Power 1						SP1
504	4	Switch Power 2						SP2

## Modbus Addressing Convention

All Modbus addresses refer to Modbus holding registers. When writing your own Modbus scripts, use the appropriate commands for interfacing to holding registers. Parameter description headings refer to addresses in the range of 40000 as is customary with Modbus convention.

## Storage and Sleep Modes

**Storage Mode** (applies to battery-powered models only)—While in **storage mode**, the radio does not operate. To put any integrated battery Sure Cross® radio into storage mode, press and hold button 1 for five seconds. To wake the device, press and hold button 1 for five seconds. The radio is in storage mode when the LEDs stop blinking, but in some models, the LCD remains on for an additional minute after the radio enters storage mode. After a device has entered storage mode, you must wait one minute before waking it.

**Sleep Mode** (applies to both battery and 10–30 V DC powered models)—During normal operation, the Sure Cross radio devices enter **sleep mode** after 15 minutes of operation. The radio continues to function, but the LCD goes blank. To wake the device, press any button.

## Install or Replace the Battery on a DX80E Model

Follow these steps to replace the lithium "D" cell battery or batteries in any DX80E model.

1. Remove the four screws mounting the face plate to the housing and remove the face plate. If there is a radio cover on the faceplate, do not remove the radio cover from the faceplate.
2. If applicable, remove the discharged battery or batteries.
3. Install the new battery or batteries.
4. Verify the positive and negative terminals align to the positive and negative terminals of the battery holder mounted within the case.
5. Allow up to 60 seconds for the device to power up.
6. Properly dispose of used batteries according to local regulations by taking it to a hazardous waste collection site, an e-waste disposal center, or other facility qualified to accept lithium batteries.



**CAUTION:** There is a risk of explosion if the battery is replaced incorrectly.

For outside or high-humidity environments, dielectric grease may be applied to the battery terminals to prevent moisture and corrosion buildup.

As with all batteries, these are a fire, explosion, and severe burn hazard. Do not burn or expose them to high temperatures. Do not recharge, crush, disassemble, or expose the contents to water.

For non-hazardous locations, the replacement battery is model **BWA-BATT-011**. For non-hazardous or hazardous locations, the replacement battery is Xeno model XL-205F, Banner model **BWA-BATT-001**. For pricing and availability, contact Banner Engineering.





# Specifications

---

## Radio Specifications for 900 MHz MultiHop

### Radio Transmit Power (900 MHz, 500 mW radios)

Conducted: 27 dBm (500 mW)  
EIRP with the supplied antenna: < 36 dBm

### Radio Range

A 2 dB antenna ships with this device.  
Transmit power and range are subject to many factors, including antenna gain, installation methods, characteristics of the application, and environmental conditions.  
Please refer to the following documents for installation instructions and high-gain antenna options.

Installing Your Sure Cross® Radios ([151514](#))  
Conducting a Site Survey ([133602](#))  
Sure Cross® Antenna Basics ([132113](#))

### Antenna Minimum Separation Distance

900 MHz radios transmitting at  $\geq 500$  mW: 4.57 m (15 ft) with the supplied antenna

### Spread Spectrum Technology

FHSS (Frequency Hopping Spread Spectrum)

### Antenna Connection

Ext. Reverse Polarity SMA, 50 Ohms  
Max Tightening Torque: 0.45 N·m (4 lbf·in)

### 900 MHz Compliance (SX7023EXT Radio Module)

Radio module is indicated by the product label marking  
Contains FCC ID: UE3SX7023EXT  
Contains IC: 7044A-SX7023EXT

### Radio Packet Size (MultiHop)

900 MHz: 175 bytes (85 Modbus registers)  
2.4 GHz: 75 bytes (37 Modbus registers)

## FCC Part 15 Class A for Intentional Radiators

This equipment has been tested and found to comply with the limits for a Class A digital device, pursuant to Part 15 of the FCC Rules. These limits are designed to provide reasonable protection against harmful interference when the equipment is operated in a commercial environment. This equipment generates, uses, and can radiate radio frequency energy and, if not installed and used in accordance with the instruction manual, may cause harmful interference to radio communications. Operation of this equipment in a residential area is likely to cause harmful interference in which case the user will be required to correct the interference at his own expense.

(Part 15.21) Any changes or modifications not expressly approved by the party responsible for compliance could void the user's authority to operate this equipment.

## Industry Canada Statement for Intentional Radiators

This device contains licence-exempt transmitters(s)/receiver(s) that comply with Innovation, Science and Economic Development Canada's licence-exempt RSS(s). Operation is subject to the following two conditions:

1. This device may not cause interference.
2. This device must accept any interference, including interference that may cause undesired operation of the device.

Cet appareil contient des émetteurs/récepteurs exemptés de licence conformes à la norme Innovation, Sciences, et Développement économique Canada. L'exploitation est autorisée aux deux conditions suivantes:

1. L'appareil ne doit pas produire de brouillage.
2. L'utilisateur de l'appareil doit accepter tout brouillage radioélectrique subi, même si le brouillage est susceptible d'en compromettre le fonctionnement.

## RS-485 Communication Specifications

### Communication Hardware (MultiHop RS-485)

Interface: 2-wire half-duplex RS-485

Baud rates: 9.6k, 19.2k (default), or 38.4k via DIP switches;  
1200 and 2400 via the MultiHop Configuration Software  
Data format: 8 data bits, no parity, 1 stop bit

## M-H12 Specifications

### Supply Voltage

"E" Housing Models: 3.6 V DC (internal battery) or 10 V DC to 30 V DC

### Power Consumption

Client radio consumption (900 MHz): Maximum current draw is < 100 mA and typical current draw is < 30 mA at 24 V DC. (2.4 GHz consumption is less.)  
Repeater/server radio consumption (900 MHz): Maximum current draw is < 40 mA and typical current draw is < 20 mA at 24 V DC. (2.4 GHz consumption is less.)

### Wiring Access

"E" Housing Models: Two 1/2-inch NPT

### Housing

Polycarbonate housing and rotary dial cover; polyester labels; EDPM rubber cover gasket; nitrile rubber, non-sulphur cured button covers  
Weight: 0.26 kg (0.57 lbs)  
Mounting: #10 or M5 (SS M5 hardware included)  
Max. Tightening Torque: 0.56 N·m (5 lbf·in)

### Interface

Two bi-color LED indicators, Two buttons, Six character LCD

### Analog Inputs

Rating: 24 mA  
Impedance: Approximately 22 Ohms<sup>(1)</sup>  
Sample Rate: 1 second  
Accuracy: 0.1% of full scale +0.01% per °C  
Resolution: 12-bit

### Thermistor Input (MultiHop)

Model: Omega's 44006 or 44031 family of 10 kOhm thermistors  
Sample Rate: 1 second  
Accuracy: 0.4 °C (10 °C to 50 °C); Up to 0.8 °C (-40 °C to 85 °C)

### Discrete Output

ON Condition: Less than 0.7 V  
OFF Condition: Open

<sup>(1)</sup> To verify the analog input's impedance, use an Ohm meter to measure the resistance between the analog input terminal (AIx) and the ground (GND) terminal.

**Discrete Inputs**

Rating: 3 mA max current at 30 V DC  
 Sample Rate: 40 milliseconds  
 ON Condition (NPN): Less than 0.7 V

OFF Condition (NPN): Greater than 2 V or open

**Discrete Output Rating (MultiHop NMOS)**

Less than 1 A max current at 30 V DC  
 ON-State Saturation: Less than 0.7 V at 20 mA

## Environmental Specifications for the E Housing

**Operating Conditions**

-40 °C to +85 °C (-40 °F to +185 °F) (Electronics); -20 °C to +80 °C (-4 °F to +176 °F) (LCD)  
 95% maximum relative humidity (non-condensing)  
 Radiated Immunity: 10 V/m (EN 61000-4-3)

**Shock and Vibration**

All models meet IEC 60068-2-6 and IEC 60068-2-27 testing criteria  
 Shock: 30G 11 ms duration, half sine wave per IEC 60068-2-27  
 Vibration: 10 Hz to 55 Hz, 0.5 mm peak-to-peak amplitude per IEC 60068-2-6

**Environmental Ratings**

IP65  
 Refer to the Sure Cross® DX80 Performance (p/n [132607](#)) or the Sure Cross® MultiHop (p/n [151317](#)) instruction manual for installation and waterproofing instructions.

Operating the devices at the maximum operating conditions for extended periods can shorten the life of the device.

## Accessories

### Included with the DX80..E Models

- Mounting hardware kit
- BWA-HW-003: PTFE tape
- BWA-9O2-C (900 MHz) or BWA-2O2-C (2.4 GHz): Antenna, 2 dBd Omni, Rubber Swivel RP-SMA Male. (Not included with Internal antenna models)
- BWA-BATT-001: Replacement battery, 3.6 Volt, "D" Lithium Cell
- BWA-HW-032: Access Hardware for "E" Housing (One each of 1/2-inch plug, 1/2-inch gland)
- Product datasheet and product family Quick Start Guide ([128185](#) for DX80 Gateways or [152653](#) for MultiHop models)

## Thermistor Probes

**BWA-THERMISTOR-PROBE-003**

- Temperature sensor with thermistor **PS103G2**
- Beta Value(K) 0-50°C: 3575
- Base thermistor accuracy of 0.2%
- Operating Temperature Range: -20 °C to +105 °C (-4 °F to +221 °F)
- Maximum Power Rating: 30 mW at 25 °C; derated to 1 mW at 125 °C
- Dissipation Constant: 1 mW/°C
- 316 stainless steel finish; PVC insulation

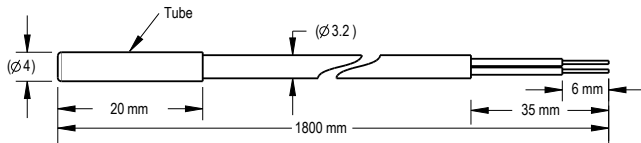

## Splitter Cordsets

5-Pin Double-Ended M12 Female to M12 Male Flat Junction Splitter Cordsets			
Model	Description	Pinout (Male)	Pinout (Female)
<b>CSB4-M1251M1250</b>	Four (no cable) 5-pin M12 female quick-disconnect connectors  One 0.3 m (0.98 ft) cable with a 5-pin M12 male quick-disconnect connector  Parallel wiring		

Continued on page 11

Continued from page 10

5-Pin Double-Ended M12 Female to M12 Male Flat Junction Splitter Cordsets			
Model	Description	Pinout (Male)	Pinout (Female)
		1 = Brown 2 = White 3 = Blue 4 = Black 5 = Gray	1 = Brown 2 = White 3 = Blue 4 = Black 5 = Gray

5-Pin M12 Female to M12 Male Splitter Tee			
Model	Description	Pinout (Male)	Pinout (Female)
<b>CSB-M1250M1250-T</b> <ul style="list-style-type: none"> <li>Two 5-pin M12 female quick-disconnect connectors</li> <li>One 5-pin M12 male quick-disconnect connector</li> <li>Parallel wiring</li> </ul>		 1 = Brown 2 = White 3 = Blue 4 = Black 5 = Gray	 1 = Brown 2 = White 3 = Blue 4 = Black 5 = Gray

## Warnings

**WARNING:**

- Do not use this device for personnel protection
- Using this device for personnel protection could result in serious injury or death.
- This device does not include the self-checking redundant circuitry necessary to allow its use in personnel safety applications. A device failure or malfunction can cause either an energized (on) or de-energized (off) output condition.

**IMPORTANT:** Please download the complete MultiHop H12 Data Radio technical documentation, available in multiple languages, from [www.bannerengineering.com](http://www.bannerengineering.com) for details on the proper use, applications, Warnings, and installation instructions of this device.

**IMPORTANT:** Por favor descargue desde [www.bannerengineering.com](http://www.bannerengineering.com) toda la documentación técnica de los MultiHop H12 Data Radio, disponibles en múltiples idiomas, para detalles del uso adecuado, aplicaciones, advertencias, y las instrucciones de instalación de estos dispositivos.

**IMPORTANT:** Veuillez télécharger la documentation technique complète des MultiHop H12 Data Radio sur notre site [www.bannerengineering.com](http://www.bannerengineering.com) pour les détails sur leur utilisation correcte, les applications, les notes de sécurité et les instructions de montage.

**Install and properly ground a qualified surge suppressor when installing a remote antenna system.** Remote antenna configurations installed without surge suppressors invalidate the manufacturer's warranty. Keep the ground wire as short as possible and make all ground connections to a single-point ground system to ensure no ground loops are created. No surge suppressor can absorb all lightning strikes; do not touch the Sure Cross® device or any equipment connected to the Sure Cross® device during a thunderstorm.

**Exporting Sure Cross® Radios.** It is our intent to fully comply with all national and regional regulations regarding radio frequency emissions. **Customers who want to re-export this product to a country other than that to which it was sold must ensure the device is approved in the destination country.** The Sure Cross wireless products were certified for use in these countries using the antenna that ships with the product. When using other antennas, verify you are not exceeding the transmit power levels allowed by local governing agencies. This device has been designed to operate with the antennas listed on Banner Engineering's website and having a maximum gain of 9 dBm. Antennas not included in this list or having a gain greater than 9 dBm are strictly prohibited for use with this device. The required antenna impedance is 50 ohms. To reduce potential radio interference to other users, the antenna type and its gain should be so chosen such that the equivalent isotropically radiated power (EIRP) is not more than that permitted for successful communication. Consult with Banner Engineering Corp. if the destination country is not on this list.

**IMPORTANT:**

- Never operate a radio without connecting an antenna**
- Operating radios without an antenna connected will damage the radio circuitry.
- To avoid damaging the radio circuitry, never apply power to a Sure Cross® Performance or Sure Cross® MultiHop radio without an antenna connected.

**IMPORTANT:**

- Electrostatic discharge (ESD) sensitive device**
- ESD can damage the device. Damage from inappropriate handling is not covered by warranty.
- Use proper handling procedures to prevent ESD damage. Proper handling procedures include leaving devices in their anti-static packaging until ready for use; wearing anti-static wrist straps; and assembling units on a grounded, static-dissipative surface.

## Banner Engineering Corp Limited Warranty

Banner Engineering Corp. warrants its products to be free from defects in material and workmanship for one year following the date of shipment. Banner Engineering Corp. will repair or replace, free of charge, any product of its manufacture which, at the time it is returned to the factory, is found to have been defective during the warranty period. This warranty does not cover damage or liability for misuse, abuse, or the improper application or installation of the Banner product.

**THIS LIMITED WARRANTY IS EXCLUSIVE AND IN LIEU OF ALL OTHER WARRANTIES WHETHER EXPRESS OR IMPLIED (INCLUDING, WITHOUT LIMITATION, ANY WARRANTY OF MERCHANTABILITY OR FITNESS FOR A PARTICULAR PURPOSE), AND WHETHER ARISING UNDER COURSE OF PERFORMANCE, COURSE OF DEALING OR TRADE USAGE.**

This Warranty is exclusive and limited to repair or, at the discretion of Banner Engineering Corp., replacement. **IN NO EVENT SHALL BANNER ENGINEERING CORP. BE LIABLE TO BUYER OR ANY OTHER PERSON OR ENTITY FOR ANY EXTRA COSTS, EXPENSES, LOSSES, LOSS OF PROFITS, OR ANY INCIDENTAL, CONSEQUENTIAL OR SPECIAL DAMAGES RESULTING FROM ANY PRODUCT DEFECT OR FROM THE USE OR INABILITY TO USE THE PRODUCT, WHETHER ARISING IN CONTRACT OR WARRANTY, STATUTE, TORT, STRICT LIABILITY, NEGLIGENCE, OR OTHERWISE.**

Banner Engineering Corp. reserves the right to change, modify or improve the design of the product without assuming any obligations or liabilities relating to any product previously manufactured by Banner Engineering Corp. Any misuse, abuse, or improper application or installation of this product or use of the product for personal protection applications when the product is identified as not intended for such purposes will void the product warranty. Any modifications to this product without prior express approval by Banner Engineering Corp will void the product warranties. All specifications published in this document are subject to change; Banner reserves the right to modify product specifications or update documentation at any time. Specifications and product information in English supersede that which is provided in any other language. For the most recent version of any documentation, refer to: [www.bannerengineering.com](http://www.bannerengineering.com).

For patent information, see [www.bannerengineering.com/patents](http://www.bannerengineering.com/patents).

## Notas Adicionales (con Antena)

Información México: La operación de este equipo está sujeta a las siguientes dos condiciones: 1) es posible que este equipo o dispositivo no cause interferencia perjudicial y 2) este equipo debe aceptar cualquier interferencia, incluyendo la que pueda causar su operación no deseada.

Banner es una marca registrada de Banner Engineering Corp. y podrán ser utilizadas de manera indistinta para referirse al fabricante. "Este equipo ha sido diseñado para operar con las antenas tipo Omnidireccional para una ganancia máxima de antena de 6 dBd y Yagi para una ganancia máxima de antena 10 dBd que en seguida se enlistan. También se incluyen aquellas con aprobación ATEX tipo Omnidireccional siempre que no excedan una ganancia máxima de antena de 6dBd. El uso con este equipo de antenas no incluidas en esta lista o que tengan una ganancia mayor que 6 dBd en tipo omnidireccional y 10 dBd en tipo Yagi, quedan prohibidas. La impedancia requerida de la antena es de 50 ohms."

### Approved Antennas

**BWA-902-C**--Antena, Omni 902-928 MHz, 2 dBd, junta de caucho, RP-SMA Macho  
**BWA-905-C**--Antena, Omni 902-928 MHz, 5 dBd, junta de caucho, RP-SMA Macho  
**BWA-906-A**--Antena, Omni 902-928 MHz, 6 dBd, fibra de vidrio, 1800mm, N Hembra  
**BWA-9Y10-A**--Antena, Yagi, 900 MHz, 10 dBd, N Hembra

## Mexican Importer

Banner Engineering de México, S. de R.L. de C.V. | David Alfaro Siqueiros 103 Piso 2 Valle oriente | San Pedro Garza Garcia Nuevo León, C. P. 66269

81 8363.2714