

SP320D

Miniature Diffuse Mode Remote Sensor



The SP320D is a rugged, encapsulated, infrared diffuse mode sensor in a miniature plastic package designed to fit into very tight locations. Its performance characteristics are identical to the larger SP300D. It mounts using two #4 (3mm) screws, and is ideal for nearly any presence sensing application where small size, high performance, and economy are important.

SP320D sensors have hermetically sealed lenses to eliminate internal condensation, and are supplied with 6 feet of extremely flexible, low-profile cable. Units may be washed down without damage.

This sensor is designed for use with Banner MICRO-AMP® system MA3-4 and MA3-4P modulated amplifiers, MAXI-AMP™ system CM Series modulated amplifiers, and MB Series amplifiers.

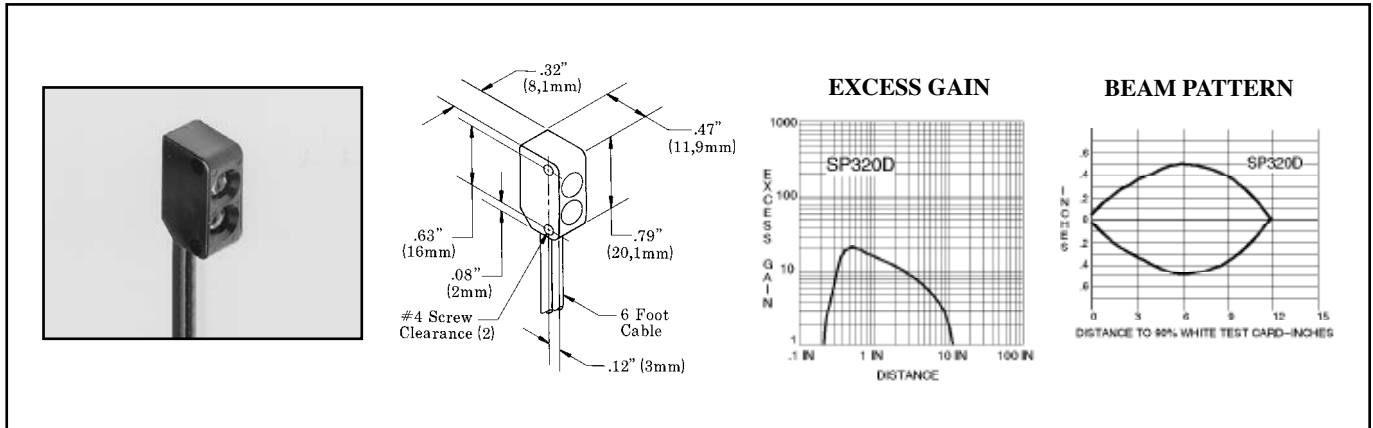

Specifications, SP320D

RANGE: up to 12 inches (30cm)

RESPONSE SPEED: a function of the amplifier (see below)

OPERATING TEMPERATURE: -40 to +80° C (-40 to +176° F)

EMITTER CHARACTERISTICS: infrared LED, 880nm

CONSTRUCTION: totally encapsulated, hermetically sealed lenses. Black Valox® housing; NEMA 1, 3, 4, 12, and 13.

CABLE: sensors are supplied with 6' of low-profile PVC-covered 4-conductor cable. 30' cables are available by special order.

Wiring rules:

- 1) Avoid running remote sensor cables in wireways together with power-carrying conductors.
- 2) Avoid running remote sensor cables through areas of known extreme electrical interference (electrical "noise").
- 3) Always use shielded cables and only connect the shield ("drain") wire at the amplifier.
- 4) When splicing, never combine emitter and receiver wires into a common cable. (The result will be electrical "crosstalk" within the cable, which causes a "lock-on" condition of the amplifier.)

Hookup to MB Series Amplifiers

Banner remote sensors will connect to any MB Series amplifier. The model MRB chassis (shown) has octal sockets for the amplifier and a BR-2 relay (supplied) and provides power for the sensors and amplifier. Up to four sensors may be connected to one amplifier for light-operated OR or dark operated AND operation. In multiple-sensor hookups, receivers are wired in parallel and emitters are connected in series (see example for CM Series modules, next page).

Several MB Series amplifiers are available. Each provides a different output logic function. Refer to the Banner catalog for more information.

Chassis models with additional octal sockets are also available. Other types of output devices, including solid state relays, may be ordered (see Banner catalog).

Specifications, MB Series Amplifiers

POWER SUPPLY REQUIREMENT: 12-18V dc at less than 100mA, exclusive of load.

OUTPUT CONFIGURATION: open collector NPN transistor; maximum on-state current 250mA, maximum off-state leakage current 100 microamps.

RESPONSE SPEED: 1 millisecond ON and OFF.

MAXIMUM SENSOR LEAD LENGTH: 100 ft. (30 m) maximum; use separate shielded cables for emitter and receiver.

OPERATING TEMPERATURE RANGE: 0 to +50°C (+32 to +122° F).

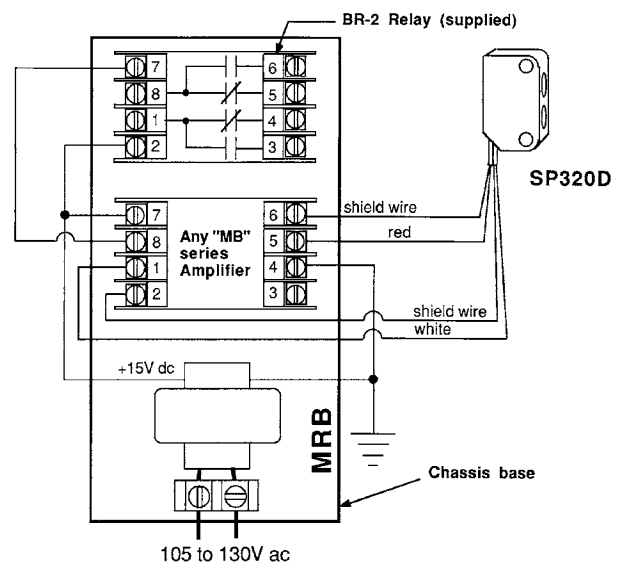

Hookup to MAXI-AMP™ CM Series Modules

CM Series modules combine power supply, modulated photoelectric amplifier, timing logic (CM5 models), and output relay in a single compact module. Only an 11-pin relay socket (Banner model RS-11) is needed to complete the system.

The CM Series contains models with or without programmable timing logic and with either electromechanical or solid-state relay outputs (models are listed in the tables, below).

Up to three sensors may be connected to each amplifier. Light-operated OR logic (input to module occurs whenever at least one receiver sees

"light") or dark-operated AND logic (input to module occurs when all receivers simultaneously see "dark") is possible.

NOTE: to power the MAXI-AMP from a DC power supply, connect +12 to 28V dc at $\geq 70\text{mA}$ to terminal #3 and DC common to terminal #1. Make no connections to terminal #7 or #8.

To a Single Sensor

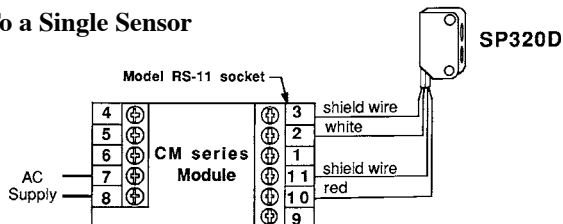

To Multiple Sensors

When wiring two sensors to one MAXI-AMP, multiply excess gain data (from excess gain curve) for each sensor by 1/2; when wiring three sensors to one MAXI-AMP, multiply excess gain by 1/3.

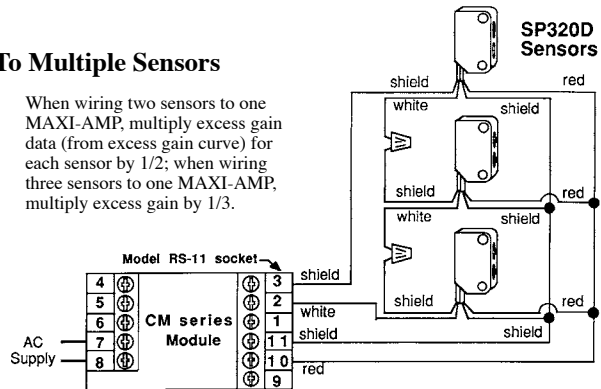

Specifications, MAXI-AMP CM Series Modules

RESPONSE SPEED: programmable for 10, 2, or 0.3 milliseconds (10 millisecond setting enhances noise rejection).

MAXIMUM SENSOR LEAD LENGTH: 50' (15m) maximum. To avoid "cable crosstalk", use *separate* shielded cable for emitter and receiver, or order sensors with extended cable length.

OPERATING TEMPERATURE RANGE: 0 to +50 degrees C (+32 to +122 degrees F).

Hookup to MICRO-AMP® Modules

MICRO-AMP amplifier module models MA3-4 and MA3-4P may be used with this sensor. Model MA3-4 has complementary *current sinking* outputs. Model MA3-4P has complementary *current sourcing* outputs.

Model MA3-4 (but *not* model MA3-4P) may be powered by the model MPS-15 power supply, as shown in the hookup diagram (right). The MPS-15 includes a socket for the MA3-4 and has a built-in SPDT output relay (switchable by the MA3-4 module).

MICRO-AMP modules may also be mounted in a model RS8 wiring socket and powered from a "remote" power supply. PVC mounting track is available in 6" and 12" lengths to accommodate multiple MICRO-AMP system components.

NOTE: only one SP320D may be connected to each amplifier.

Specifications, MICRO-AMP MA3-4 and MA3-4P

POWER SUPPLY REQUIREMENT: 10-30V dc at less than 20mA; 10% maximum ripple (obtainable from MPS-15 power supply--see above).

OUTPUT CONFIGURATION: model MA3-4 has two open-collector NPN (current sinking) transistor solid state switches, one normally open, one normally closed. 150mA max. each output. Model MA3-4P has two PNP (sourcing) outputs, 150mA max. each.

RESPONSE SPEED: 1 millisecond ON and OFF.

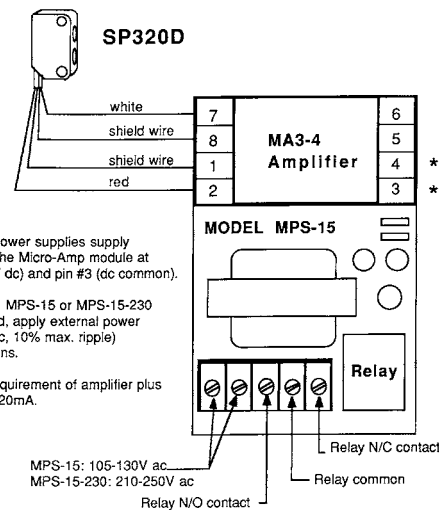

*MPS-15 power supplies supply power to the Micro-Amp module at pin #4 (+V dc) and pin #3 (dc common).

When the MPS-15 or MPS-15-230 is not used, apply external power (10-30V dc, 10% max. ripple) at these pins.

Current requirement of amplifier plus sensor is 20mA.

MAXIMUM SENSOR LEAD LENGTH: 30' (9m).

OPERATING TEMPERATURE RANGE: -40 to +70 degrees C (-40 to +158 degrees F).



WARNING These photoelectric presence sensors and amplifiers do NOT include the self-checking redundant circuitry necessary to allow their use in personnel safety applications. A sensor or amplifier failure or malfunction can result in *either* an energized or a de-energized sensor output condition.

Never use these products as sensing devices for personnel protection. Their use as safety devices may create an unsafe condition which could lead to serious injury or death.

Only MACHINE-GUARD and PERIMETER-GUARD Systems, and other systems so designated, are designed to meet OSHA and ANSI machine safety standards for point-of-operation guarding devices. No other Banner sensors or controls are designed to meet these standards, and they must NOT be used as sensing devices for personnel protection.

WARRANTY: Banner Engineering Corporation warrants its products to be free from defects for a period of one year. Banner Engineering Corporation will repair or replace, free of charge, any product of its manufacture found to be defective at the time it is returned to the factory during the warranty period. This warranty does not cover damage or liability for the improper application of Banner products. This warranty is in lieu of any other warranty either expressed or implied.