

MAXI-AMP™ CL Series

Logic-level Input Modules

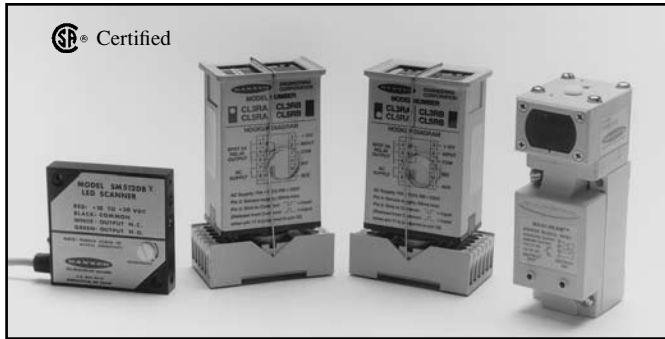

MODEL	SUPPLY VOLTAGE	OUTPUT	LOGIC
CL3RA	105 to 130V ac, or 12 to 28V dc	SPDT electro-mechanical relay, plus NPN transistor solid-state switch	ON/OFF
CL3RB	210 to 250V ac, or 12 to 28V dc		
CL5RA	105 to 130V ac, or 12 to 28V dc	SPDT electro-mechanical relay (5 amp contact rating)	12 timing functions
CL5RB	210 to 250V ac, or 12 to 28V dc		

Banner CL Series MAXI-AMP™ modules are the perfect solution for many sensing/control applications where economy, versatility, dependability, and ruggedness are important. CL Series MAXI-AMPs combine power supply, timing logic (in CL5 models) and output relay in a single compact, cost-saving module. The integrated, *stand-alone* design saves both the expense of a separate control chassis and a substantial amount of panel space. Several models are available, for either 120V ac or 240V ac operation, and either with or without timing logic (models are listed in table at above right). Alternatively, any model may be powered by 12 to 28V dc.

The well-defined electrical characteristics of CL Series MAXI-AMP modules provide a wealth of application possibilities. The input circuit accepts signals from any Banner dc sensor with an NPN (current sinking) output; as well as from MAXI-AMP, MICRO-AMP, and Plug Logic modules. The input is compatible with almost any sensor or circuit which has an NPN transistor (current sinking) output. Additionally, inputs may be generated by limit switches, contact closures, and optical couplers. A 50mA power supply is included for powering 10 to 30V dc devices.

CL5 models offer a versatile multi-function timing logic circuit which is programmable for twelve of the most popular and useful delay, one-shot, and latch functions (see page 5). The MAXI-AMP offers the choice of either single or dual timing functions in the same module. Logic and timing may be easily reprogrammed as control requirements change.

In order to allow accurate timing adjustments, each CL5 model has three time ranges to choose from. Timing adjustments are made via rugged 15-turn potentiometers. Circuitry is included to prevent any possibility of false output on power-up.

An auxiliary input is available on CL5 models for interrogation or reset of the selected logic function by using an additional sensor or input signal (see example, page 3). Page 5 describes the function of the auxiliary input for each logic mode.

The output circuit for all CL Series modules is an SPDT 5-amp electro-mechanical relay. A solid-state relay is offered as an option to the electromechanical relay (see information below).

Additionally, CL3 models have an NPN transistor solid-state switch. This solid-state output may be used to take advantage of the amplifier's fast 1-millisecond response. This output may be connected directly to the primary or auxiliary input of other Banner logic modules, including CL5 modules, MICRO-AMP logic modules, and Plug Logic modules. In addition, this output can interface to other dc devices or circuits such as counters, rate meters, or programmable controllers. Switching capacity is 20mA at 12V dc. The output may be programmed for either normally open or normally closed operation.

Like all MAXI-AMPs, the CL Series modules are designed both electrically and mechanically for solid dependability in industrial environments.

Solid-state Output Option

CL Series modules are available with a solid-state relay which replaces the electromechanical relay. This is actually two SPST solid-state contacts. One contact will switch ac loads, and is rated at 250V ac maximum and 3/4 amps maximum at 25 degrees C (derated to 1/2 amp at 50 degrees C). A solid-state contact is particularly helpful when switching inductive ac loads which can cause electrical "noise" and contact damage when switched with a "hard" relay contact.

The other solid-state contact will switch dc loads of up to 30V dc and up to 50 milliamps. Both solid-state outputs are electrically isolated from the MAXI-AMP power supply. Both outputs switch within the 1 millisecond response time of the CL module circuitry. NOTE: ac loads may take up to 1/2 cycle (8.3 milliseconds) to turn "off".

Both outputs are normally open, but may be programmed for normally closed operation.

Except for the output configuration, the specifications for the models listed in the table at the right are exactly the same as for the standard CL Series models.

MODEL	SUPPLY VOLTAGE	OUTPUT	LOGIC
CL3A	105 to 130V ac, or 12 to 28V dc	SPST solid-state contact for switching AC loads up to 250V ac and up to 3/4 amp, plus solid-state contact for switching dc loads up to 30V dc and up to 50mA.	ON/OFF
CL3B	210 to 250V ac, or 12 to 28V dc		
CL5A	105 to 130V ac, or 12 to 28V dc		12 timing functions
CL5B	210 to 250V ac, or 12 to 28V dc		

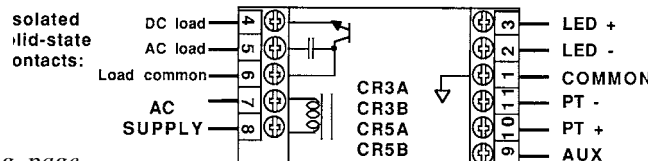

Please read Personnel Safety Warning, page 3.

MAXI-AMP CL Series Specifications

SUPPLY VOLTAGE: Models CL3RA, CL5RA: 105 to 130V ac, 50/60Hz (4 VA), or 12 to 28V dc* at 60mA. Models CL3RB, CL5RB: 210 to 250V ac, 50/60Hz (4 VA), or 12 to 28V dc at 60mA. ***Do not connect ac voltage if using external dc power.**

OUTPUT CONFIGURATION: all models have SPDT electro-mechanical relay:

CONTACT RATING: 250V ac max, 24V dc max, 5 amps max. (resistive load), 1/10 H.P. at 240V ac. Install transient suppressor (MOV) across contacts which switch inductive loads.

CLOSURE TIME: 10 milliseconds max.

RELEASE TIME: 10 milliseconds max.

MAXIMUM SWITCHING SPEED: 20 operations/second

MECHANICAL LIFE: 20,000,000 operations

CL3 models also have a logic level current sinking NPN transistor switch at pin #9. See schematic below and hookup info.

AMPLIFIER:

RESPONSE SPEED: 1 millisecond

INPUT CHARACTERISTICS: input is switched when the voltage at pin #2 is pulled below 1V dc or when less than 1K ohms is connected between pins #2 and #1. When an inverting jumper is connected between pins #10 and #11, input is switched when the voltage at pin #2 rises above 4.5V dc or when the impedance between pins #2 and #1 exceeds 15K ohms.

HYSTERESIS: greater than .35 volts, less than 2 volts.

MULTIPLE SENSOR HOOKUP: any number of switched output devices may be connected in parallel to the input (see hookup example).

TIMERS (CL5 models only):

TIME RANGES: LOW range - 10 to 150 milliseconds

MIDDLE range - 0.1 to 1.5 seconds

HIGH range - 1 to 15 seconds

REPEATABILITY: +/-2% of set time over all extremes of supply voltage and temperature

ADJUSTMENTS: Miniature switches for setting of timing function, timing range, and output polarity (CL5 models). 15-turn clutched potentiometer for time setting (CL5 models).

INDICATOR LEDs: Red indicator LEDs for input and output status.

CONSTRUCTION: Rugged NORYL® polyphenylene oxide (PPO®) housing, 1.6" x 2.3" x 4". Standard round-pin 11-pole plug base.

OPERATING TEMPERATURE: 0 to 50 degrees C (32 to 122 degrees F).

Generalized Hookup: models with electromechanical relay output

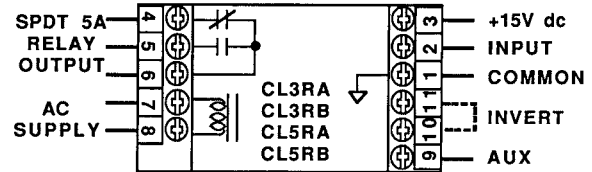

Dimension Drawing

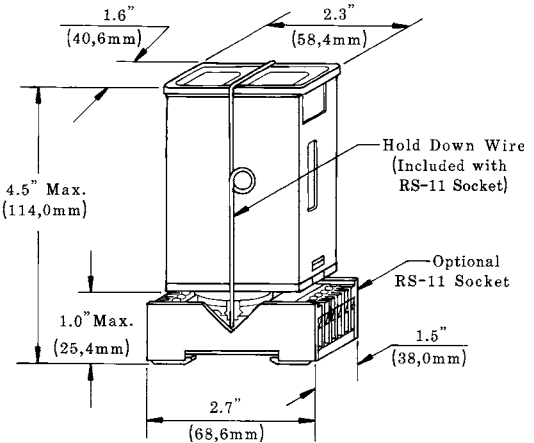

CL5 Models

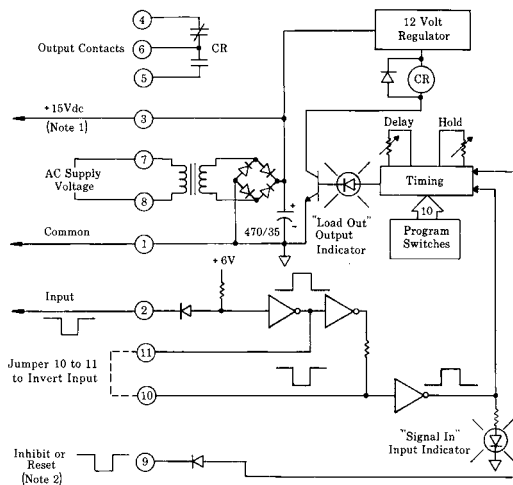

NOTE #1: power is available at pins #3 (+) and #1 (-) for an external 10 to 30V dc device (see hookup example). Current available is 50mA at 120V ac (240V ac) line level; 40mA at 105V ac (210V ac) line level. Alternately, the module may be powered by 12 to 28V dc at pins #3 (+) and #1 (-). **Do not connect ac voltage if using external dc power.**

Functional Schematics

CL3 Models

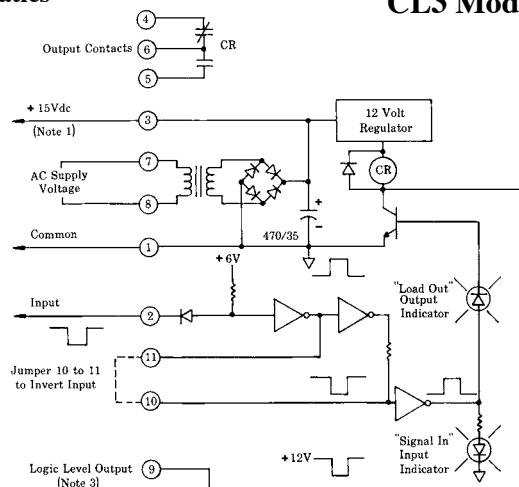

NOTE #2: pulling pin #9 low (to Common) will inhibit the timing, or reset the latch of CL5 models. (See "Description of Logic Functions", page 5)

NOTE #3: pin #9 of model CL3RA and CL3RB may be connected directly to the primary or auxiliary input of MAXI-AMP model CL5 or to Banner Plug Logic modules.

Sensor Hookup Diagrams, CL Series MAXI-AMP Modules

To MAXI-BEAM Sensors

NOTE: use power block model RPBT.

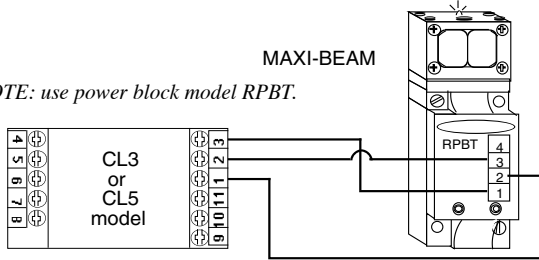

To MULTI-BEAM Sensors

NOTE: use power block model PBT or PBT2.

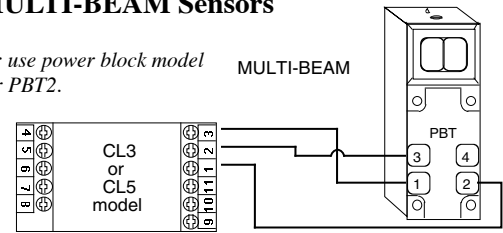

NOTE: the MAXI-AMP cannot power a MULTI-BEAM emitter and receiver pair. Use a separate power source for the emitter (e.g. power block PBA-1, etc.)

To MINI-BEAM SM312 Series Sensors

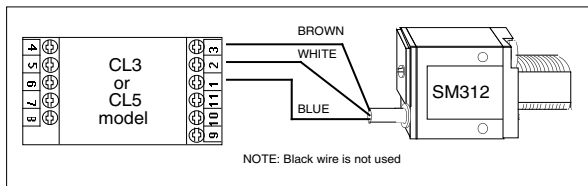

To VALU-BEAM SM912 Series Sensors

NOTE: Black wire is not used

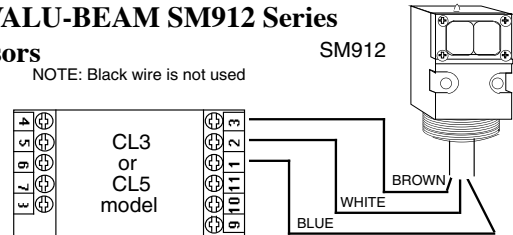

To ECONO-BEAM SE612 Series Sensors

NOTE: black wire is not used.

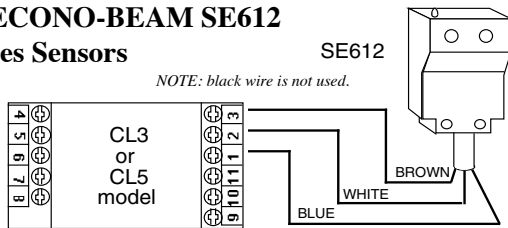

To E

NOTE: White wire is not used

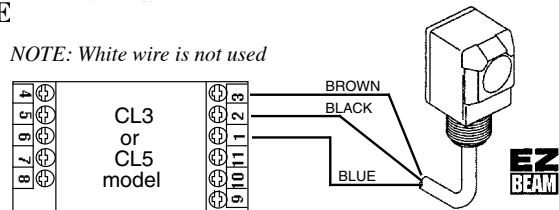

This hookup is for DC NPN (current sinking) models of S18 Series, Q25 Series, and other DC sensors bearing the EZ-BEAM logo.

Use of Auxiliary Input (CL5 models)

CL5 model MAXI-AMPs have an auxiliary input at terminal #9 which may be used for the interrogation or reset of the selected logic function. This is accomplished by a switch closure between pins #9 and #1 (Common). The auxiliary input may also be switched by a DC device with an NPN transistor (current sinking) output. The effect of the auxiliary input is described for each logic function on page 5.

This example shows a typical inspection/rejection scheme which uses a Banner MINI-BEAM as the inspection sensor. Typically, the CL5 module would be programmed for the ONE-SHOT or DELAYED ONE-SHOT logic function. If the SM312 "sees" an acceptable condition when the SE612 senses the leading (or trailing) edge of the product, the SM312 will inhibit a reject pulse from occurring. Reject products will be ejected by the output pulse.

NOTE: the MAXI-AMP can supply 50mA for external 10 to 30V dc devices. Carefully check the current draw of the devices to be powered by the MAXI-AMP.

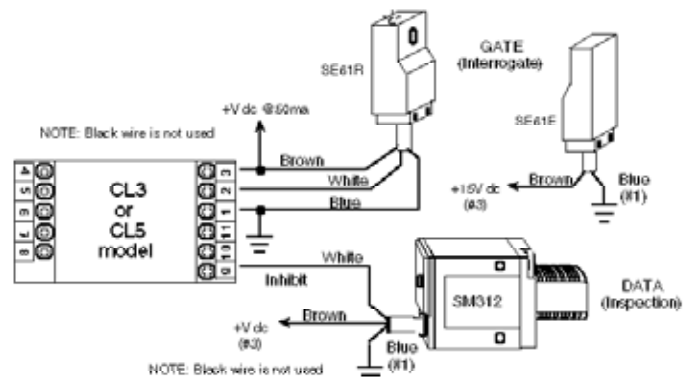

WARNING The MAXI-AMP modules described in this data sheet do NOT include the self-checking redundant circuitry necessary to allow their use in personnel safety applications. A failure or malfunction can result in either an energized or a de-energized output condition.

Never use these products for personnel protection. Their use as safety devices may create an unsafe condition which could lead to serious injury or death.

Only MACHINE-GUARD and PERIMETER-GUARD Systems, and other systems so designated, are designed to meet OSHA and ANSI machine safety standards for point-of-operation guarding devices. No other Banner sensors or controls are designed to meet these standards, and they must NOT be used as sensing devices for personnel protection.

MAXI-AMP CL Series

Hookup of Multiple Self-contained Sensors

Any number of self-contained dc sensors may be wired together in parallel to a single CL Series MAXI-AMP module to create almost any multiple-sensor logic configuration. Power for the sensors may be obtained from MAXI-AMP 400mA power supply CP12 (shown below) or from 1-amp model PS120-15. The table at the right describes how the four most frequently used multiple-sensor logic configurations may be created.

MINI-BEAM SM312 Series and VALU-BEAM SM912 Series sensors have a switch on the back of their housings which is used to program the sensors for LIGHT or DARK operate. MAXI-BEAM sensors are set for LIGHT or DARK operate using the programming ring. MULTI-BEAM sensors are programmed for LIGHT or DARK operate with the logic module jumper wire. OMNI-BEAMs are programmed by a switch in the sensor block.

For ON/OFF sensor operation, *light operate* is equated to *normally open* output, and *dark operate* is defined as *normally closed*. EZ-BEAM sensors have both a normally open and a normally closed output. Selection of either output determines the LIGHT/DARK operate mode. ECONO-BEAM sensors are not programmable and must be ordered for LIGHT OPERATE (standard models) or DARK OPERATE (model suffix "NC").

The addition of a jumper wire between MAXI-AMP terminals #10 and #11 changes the input response from a low-going to a high-going signal. This feature, combined with the selection of LIGHT or DARK operate at the sensor, allows "AND" logic with parallel sensor connections.

SENSOR PROGRAM: Light or Dark Operate	INVERTING JUMPER Installed Between Module Terminals #10 and #11	OUTPUT OCCURS (AFTER DELAY, IF ANY)	LOGIC DESCRIPTION
LIGHT OPERATE	NO	If any receiver "sees" light	LIGHT "OR"
LIGHT OPERATE	YES	When all receivers "see" dark	DARK "AND"
DARK OPERATE	NO	If any receiver "sees" dark	DARK "OR"
DARK OPERATE	YES	When all receivers "see" light	LIGHT "AND"

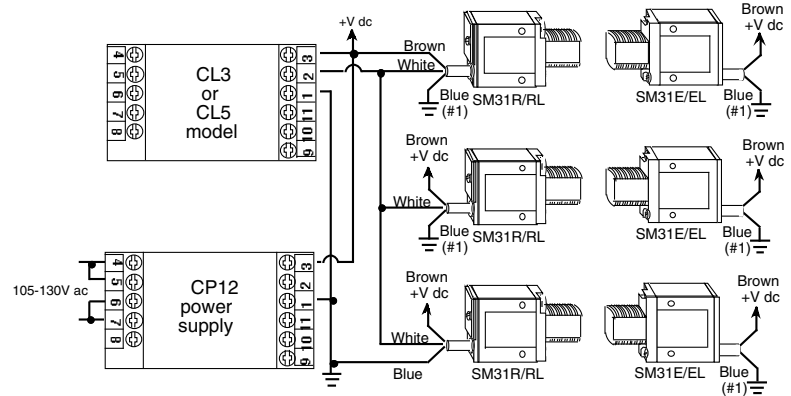

Timing Logic Programming (CL5 models)

Settings illustrated below are factory settings. Factory settings are "underlined>" in the table.

(NOTE: see page 5 for description of logic functions)

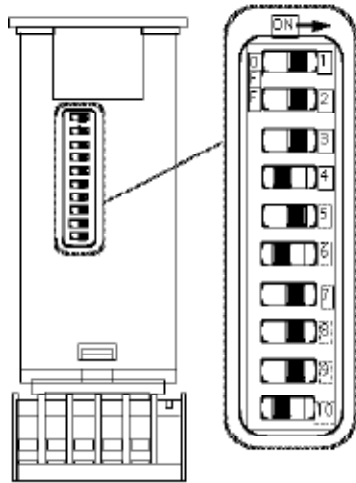

TIMING LOGIC PROGRAMMING	SWITCH #1	SWITCH #2	SWITCH #3	SWITCH #4	SWITCH #5	SWITCH #6	SWITCH #7	SWITCH #8	SWITCH #9	SWITCH #10
On/Off	<u>ON</u>	<u>ON</u>	<u>ON</u>	<u>OFF</u>	<u>ON</u>	<u>OFF</u>	<u>ON</u>	—	—	—
On Delay	<u>ON</u>	<u>ON</u>	<u>OFF</u>	<u>OFF</u>	<u>ON</u>	<u>OFF</u>	<u>ON</u>	—	—	—
Off Delay	<u>ON</u>	<u>OFF</u>	<u>ON</u>	<u>OFF</u>	<u>ON</u>	<u>OFF</u>	<u>ON</u>	—	—	—
On and Off Delay	<u>ON</u>	<u>OFF</u>	<u>OFF</u>	<u>OFF</u>	<u>ON</u>	<u>OFF</u>	<u>ON</u>	—	—	—
One-shot	<u>OFF</u>	<u>OFF</u>	<u>ON</u>	<u>OFF</u>	<u>ON</u>	<u>OFF</u>	<u>ON</u>	—	—	—
Delayed One-shot	<u>OFF</u>	<u>OFF</u>	<u>OFF</u>	<u>OFF</u>	<u>ON</u>	<u>OFF</u>	<u>OFF</u>	—	—	—
Limit	<u>ON</u>	<u>ON</u>	<u>OFF</u>	<u>OFF</u>	<u>OFF</u>	<u>OFF</u>	<u>ON</u>	—	—	—
Repeat Cycle	<u>ON</u>	<u>OFF</u>	<u>OFF</u>	<u>ON</u>	<u>ON</u>	<u>OFF</u>	<u>ON</u>	—	—	—
AC Latch	<u>OFF</u>	<u>ON</u>	<u>ON</u>	<u>OFF</u>	<u>ON</u>	<u>ON</u>	<u>ON</u>	—	—	—
DC Latch	<u>ON</u>	<u>ON</u>	<u>ON</u>	<u>OFF</u>	<u>ON</u>	<u>ON</u>	<u>ON</u>	—	—	—
Delay and Latch	<u>ON</u>	<u>ON</u>	<u>OFF</u>	<u>OFF</u>	<u>ON</u>	<u>ON</u>	<u>ON</u>	—	—	—
Limit and Latch	<u>ON</u>	<u>ON</u>	<u>OFF</u>	<u>OFF</u>	<u>OFF</u>	<u>ON</u>	<u>ON</u>	—	—	—
[N/C Output]	—	—	—	—	—	—	—	<u>OFF</u>	—	—
[N/O Output]	—	—	—	—	—	—	—	<u>ON</u>	—	—
[15 Sec. Max. Time]	—	—	—	—	—	—	—	<u>OFF</u>	<u>OFF</u>	—
[1.5 Sec. Max. Time]	—	—	—	—	—	—	—	<u>ON</u>	<u>OFF</u>	—
[15 Sec. Max. Time]	—	—	—	—	—	—	—	<u>OFF</u>	<u>ON</u>	—

A group of ten switches located on one side of the module is used to select the timing logic for CL5 models.

Switches #1 through #7 are used to select the logic function. Switch #8 programs the output for either NORMALLY OPEN or NORMALLY CLOSED operation. Switches #9 and #10 program the time range(s). There are three ranges: 10 to 150 milliseconds, 0.1 to 1.5 seconds, and 1 to 15 seconds. The programmed range will be the same for *both* functions of a dual timing mode (ON & OFF DELAY, DELAYED ONE-SHOT, and REPEAT CYCLE). However, DELAY and HOLD times are independently adjustable within the selected range.

The diagram shows switch locations, and the table summarizes the program switch positions.

Description of Logic Functions, CL5 models

ON/OFF: ON/OFF operation does not involve timing. The output simply follows the action of the input signal. Grounding pin #9 (AUXILIARY) turns the output "off", regardless of the state of the input signal. This may be accomplished by closing a switch or relay contact between pins #9 and #1 (common), or by connecting an open collector NPN (current sinking) output of any external dc device directly to pin #9. NOTE: connect the COMMON of any external dc device to pin #1 of the MAXI-AMP to establish a voltage reference between the dc supply for the external device and the internal dc supply of the MAXI-AMP.



ON DELAY: The ON DELAY timer keeps the output "off" until the selected LIGHT or DARK signal has been present for the preset "DELAY" time. If the input signal is interrupted, the timing is reset and starts over with the next signal. Grounding pin #9 immediately cancels an output in progress and resets the delay timer. The delay timer is restarted when the inhibit signal is removed, if an input signal is present.

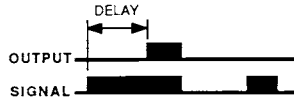

OFF DELAY: The output energizes immediately when the input signal occurs, but does not de-energize until the signal has been removed for the preset OFF-DELAY ("HOLD") time. Grounding pin #9 prevents an output from occurring. If an inhibit input occurs during an output, the output remains "on" for the remainder of the OFF-DELAY time.

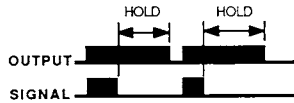

ON & OFF DELAY: ON and OFF DELAY logic combines both timing functions into a single mode. The ON-DELAY ("DELAY") time and the OFF-DELAY ("HOLD") time are independently adjustable within the selected time range. Momentary grounding of pin #9 during the ON-DELAY period resets the DELAY timer. An inhibit signal which occurs during an output will allow the output to stay energized for the remainder of the OFF-DELAY time. ON and OFF DELAY logic is often used in jam and void control, high/low level control, and edge-guiding applications.

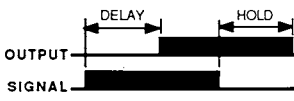

ONE-SHOT: The output of a ONE-SHOT function is a pulse of adjustable "HOLD" duration which is independent of the duration of the input signal. With the MAXI-AMP programmed for LIGHT operate, the pulse occurs when the input signal changes from dark to light. In DARK operate, the pulse occurs with a light to dark input transition. Grounding pin #9 prevents the one-shot from triggering, but does not affect a pulse already under way.

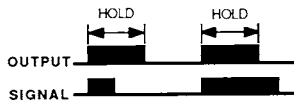

DELAYED ONE-SHOT: A DELAYED ONE-SHOT is initiated by either a momentary or maintained input signal. This input starts the adjustable "DELAY" period, after which the output pulses for an adjustable pulse ("HOLD") time. No further action occurs unless the input is removed and reapplied, beginning a new sequence. Grounding pin #9 during the delay period will cancel the sequence, and no output occurs. This feature is often used for inspection/rejection control logic. An inhibit signal will not affect a pulse under way.

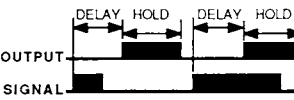

LIMIT: The output of the LIMIT function follows the action of the input, as it does with the ON/OFF function. However, an input signal which is longer than the adjustable LIMIT ("HOLD") time will turn the output "off". Removing the input signal resets the timer. This function is sometimes called "TIME LIMITED ON/OFF", and is useful for energy conservation. Grounding pin #9 cancels the output. Lifting the inhibit restarts the LIMIT timer, if an input signal is present.



REPEAT CYCLE: The REPEAT CYCLE function provides an oscillating output when an input signal is present. Presence of an input signal triggers an adjustable "DELAY" timer. After the delay, the output energizes for an adjustable "HOLD" period. If the input remains, the output continues to cycle "on" and "off" at this rate indefinitely. When the signal is removed, any output in progress completes and then remains "off" until the next signal and DELAY period. Grounding pin #9 cancels the sequence, but will allow the completion of a "HOLD" period in progress. Lifting the inhibit signal begins the DELAY period, if an input signal is present.



AC LATCH: An AC LATCH is the combination of a ONE-SHOT and a LATCH. A momentary or sustained input will latch the output "on". Grounding pin #9 will reset the latch, even if the input signal remains. The output will not re-latch until the input signal is removed and then reapplied.

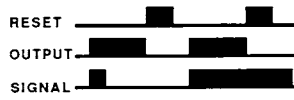

DC LATCH: The output will latch "on" whenever the selected LIGHT or DARK input condition occurs. Grounding pin #9 of a dc latch will turn the output "off" regardless of the state of the input signal. If the signal is present when the reset is removed, the output will immediately latch "on" again.

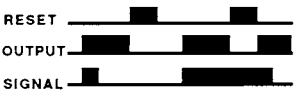

DELAY AND LATCH: The DELAY + LATCH is a combination of the ON-DELAY and DC LATCH functions. An input must be present for at least the adjustable "DELAY" time for the output to latch "on". If the input signal is removed during the timing cycle, the timing is reset. Momentary grounding of pin #9 resets the latch and/or the DELAY timing cycle. Sustained grounding of pin #9 inhibits any output.

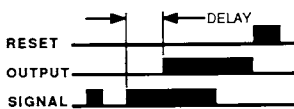

LIMIT AND LATCH: The LIMIT + LATCH operates exactly like the LIMIT function, except that the LIMIT ("HOLD") timer can be reset *only* by the auxiliary input. An output remains latched "off" until reset by momentarily grounding pin #9. In addition to resetting the timer, grounding pin #9 will hold the output "off", regardless of the state of the input signal.

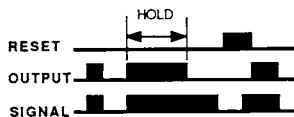

MAXI-AMP System

Mounting and Accessories

Panel Wall Mounting of MAXI-AMP Module

After the panel cutout has been completed and de-burred, slide the MAXI-AMP through the cutout and place one clip assembly into the rectangular depression on each of the two narrow sides of the housing. Orient clips as shown, and alternately tighten the screws for equal pressure against the inside of the panel wall. Do not over-tighten the screws. Attach the optional EC11-6 extension cable (described below) to the MAXI-AMP and route the opposite end of the cable to the RS-11 (or equivalent) socket.

Model EC11-6 extension cable is 6 feet (2m) long. Clips for panel wall mounting of the MAXI-AMP are included with the cable.

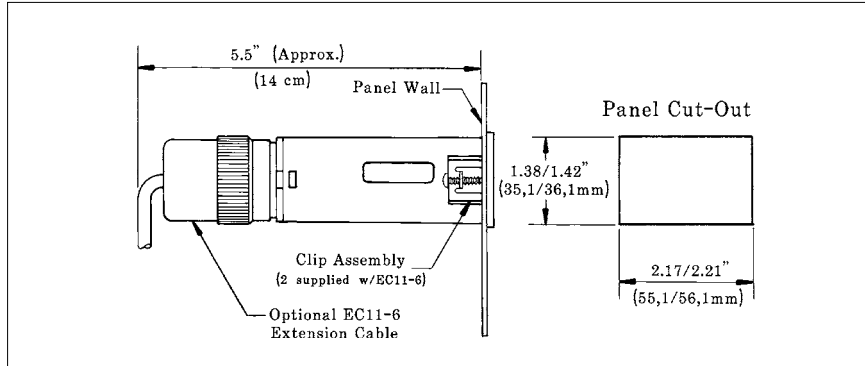

Accessories for MAXI-AMP Modules

Model RS-11 Socket

Model RS-11 is an eleven-pole round-pin screw terminal relay socket which is used to make electrical connections to any MAXI-AMP module. The socket provides in-line wire clamp screw terminals which will accept from one #24 AWG up to two #14 wires at each pin. The RS-11 is UL recognized (file #E92191) and CSA approved (file #LR38486). It may be mounted directly to a panel plate or via standard 35mm DIN-rail track (see below). A hold-down wire is supplied with each RS-11 socket (see dimension diagram on page 2).



The RS-11 is supplied with a coding ring and pin (see diagram at right). This allows a MAXI-AMP to be keyed to fit only its own 11-pin socket. The pin is installed in one of the eleven slots in the RS-11, and the notch in the ring is aligned to slip over the pin. When the MAXI-AMP is removed from the RS-11, the coding ring stays with the MAXI-AMP base, while the coding pin remains in the socket.

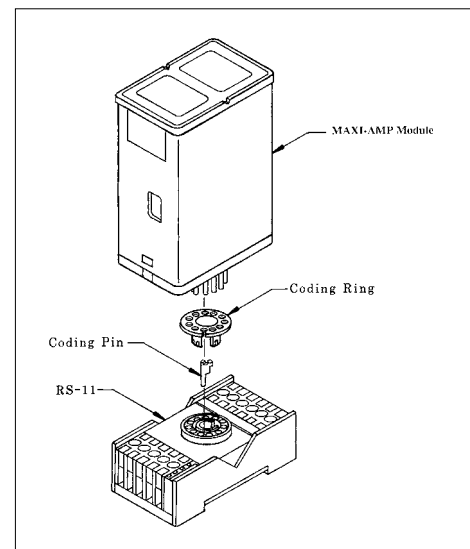

35mm DIN Rail Track

Track model DIN-35-70 accommodates one RS-11 socket. Model DIN-35-105 holds two sockets. Model DIN-35-140 holds up to three sockets. The RS-11 socket is designed to snap (or slide) directly into the 35mm DIN track.

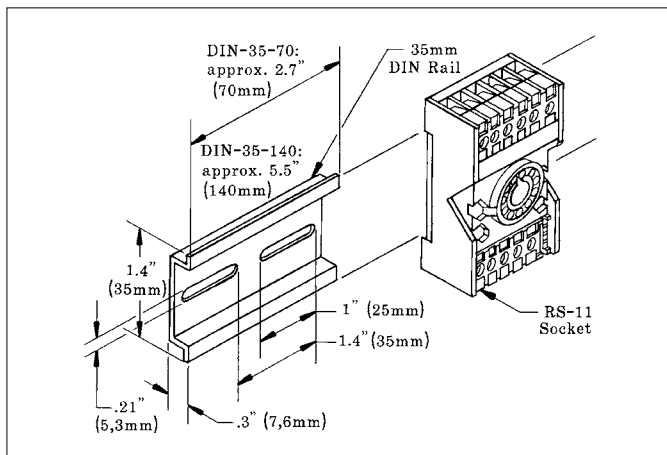

Model BENC-4 Enclosure

Model BENC-4 is a NEMA-4 rated corrosion-resistant enclosure for a MAXI-AMP module or other control device. It is supplied with a DIN-35-70 track for easy mounting of one RS-11 socket. For mounting two sockets, use DIN-35-105.

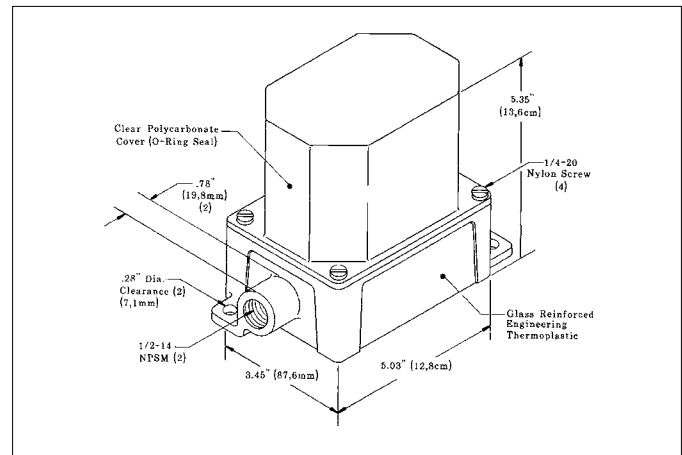

Banner Engineering Corp Limited Warranty

Banner Engineering Corp. warrants its products to be free from defects in material and workmanship for one year following the date of shipment. Banner Engineering Corp. will repair or replace, free of charge, any product of its manufacture which, at the time it is returned to the factory, is found to have been defective during the warranty period. This warranty does not cover damage or liability for misuse, abuse, or the improper application or installation of the Banner product.

THIS LIMITED WARRANTY IS EXCLUSIVE AND IN LIEU OF ALL OTHER WARRANTIES WHETHER EXPRESS OR IMPLIED (INCLUDING, WITHOUT LIMITATION, ANY WARRANTY OF MERCHANTABILITY OR FITNESS FOR A PARTICULAR PURPOSE), AND WHETHER ARISING UNDER COURSE OF PERFORMANCE, COURSE OF DEALING OR TRADE USAGE.

This Warranty is exclusive and limited to repair or, at the discretion of Banner Engineering Corp., replacement. **IN NO EVENT SHALL BANNER ENGINEERING CORP. BE LIABLE TO BUYER OR ANY OTHER PERSON OR ENTITY FOR ANY EXTRA COSTS, EXPENSES, LOSSES, LOSS OF PROFITS, OR ANY INCIDENTAL, CONSEQUENTIAL OR SPECIAL DAMAGES RESULTING FROM ANY PRODUCT DEFECT OR FROM THE USE OR INABILITY TO USE THE PRODUCT, WHETHER ARISING IN CONTRACT OR WARRANTY, STATUTE, TORT, STRICT LIABILITY, NEGLIGENCE, OR OTHERWISE.**

Banner Engineering Corp. reserves the right to change, modify or improve the design of the product without assuming any obligations or liabilities relating to any product previously manufactured by Banner Engineering Corp.

