

# MULTI-BEAM Analog Sensor

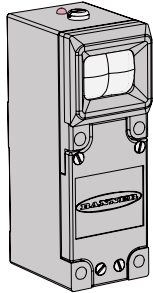

## Datasheet

The analog family of MULTI-BEAM sensors is made up of seven different Scanner Blocks, three Power Blocks, and two Logic Modules. These infrared scanners use modulated LED light sources similar to the other MULTI-BEAM sensors, but provide a variable DC voltage output that is proportional to the strength of the received signal. They are useful in many positioning and control applications where it is necessary to provide either an indication of position, or a control voltage for another analog device such as a motor speed control.



- All scanning modes are available
- Analog output proportional to signal strength
- 0–5 V DC or 4–20 mA DC output
- Powered by 120 V AC or 240 V AC, or 10–30 V DC
- Separate null and span adjustments

Applications include:

- Analog edge-guiding
- Web tension loop controls
- Feedback to motor speed controls
- Analog liquid-level control
- Position monitoring

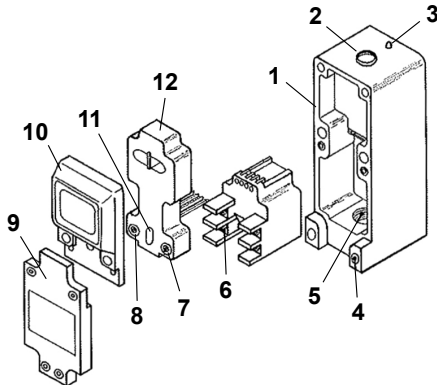

1. Scanner block housing
2. Sensitivity adjustment
3. Status/alignment indicator LED
4. Mounting hole
5. Conduit entrance
6. Wiring terminals on the power block
7. Span adjustment (factory set if unit is preassembled)
8. Zero adjustment (factory set if unit is preassembled)
9. Lower cover, supplied with the scanner block
10. Upper cover (lens), supplied with the scanner block
11. Not used in this model
12. Logic module

MULTI-BEAM modular components (scanner block, power block, and logic module) are all purchased separately.



**WARNING:**

- **Do not use this device for personnel protection**
- Using this device for personnel protection could result in serious injury or death.
- This device does not include the self-checking redundant circuitry necessary to allow its use in personnel safety applications. A device failure or malfunction can cause either an energized (on) or de-energized (off) output condition.

## Models

Active Scanner Block Models	Sensing Mode
SBL5W	Retroreflective wide-angle

Inactive Scanner Block Models	Sensing Mode
SBD5	Proximity
SBDL5	
SBF5	Fiberoptic
SBC5-1	Convergent
SBC5-4	
SBC5-6	

Inactive models are no longer available for order, but this datasheet applies to any existing inactive models currently in use.



**Ordering Information**—The MULTI-BEAM family is actually a complete scanning system, rather than a single device. Therefore the three basic elements—Scanner Block, Power Block, and Logic Module—each carries a unique model number. It is usually most convenient to select and order the parts individually. However, in some cases it becomes necessary to assign a complete model number to the assembled Multi-Beam. In these cases, simply specify the code designations for the individual parts (in sequence), leaving out the prefixes SB, PB, and LM.

For example:

- SBD5 with PBAN and LM05 becomes D5AN05
- SBDL5 with PBBN and LM420 becomes DL5BN420
- SBF5 with PBDN and LM05 becomes F5DN05

**Modification and Specials**—Due to the modular nature of the MULTI-BEAM family, it is frequently possible to deal with very special scanning, logic, or power requirements by modifying one of the three elements. Hundreds of different modifications have already been done. If the models shown in this data sheet or in the catalog do not meet your requirements, contact the Banner applications department to see if a minor modification is possible. Some general examples are:

- Scanner Block: longer ranges, faster response time, different convergent focal points, special apertures, special mounting brackets
- Power Block: different supply voltages, special output interfaces.

**Upper Cover Interchangeability**—Many of the Scanner Blocks may be converted in the field to other scanning modes by interchanging covers; in such cases, the performance specifications may be somewhat reduced. But, in general, it will be satisfactory. Some examples are:

- SBDL5 with UC-F becomes SBF5
- SBC5-1 with UDC-L becomes SBL5
- SBL5W with UC-C becomes SBC5-1

## Wiring Diagrams and Functional Schematic

Figure 1. Wiring for PBAN or PBBN with LM05 (AC Power Block)

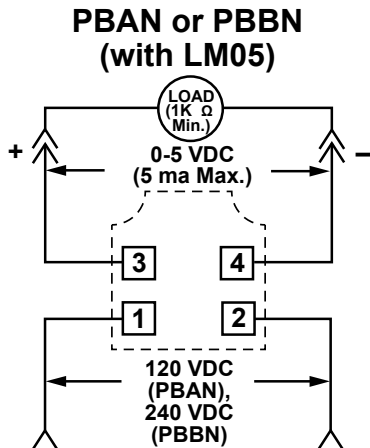

Figure 2. Wiring for PBDN with LM05 (DC Power Block)

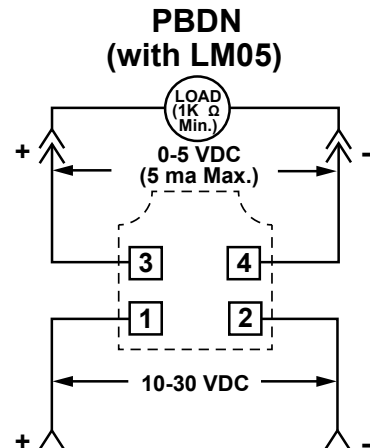

Figure 3. Wiring for PBAN or PBBN with LM420 (AC Power Block)

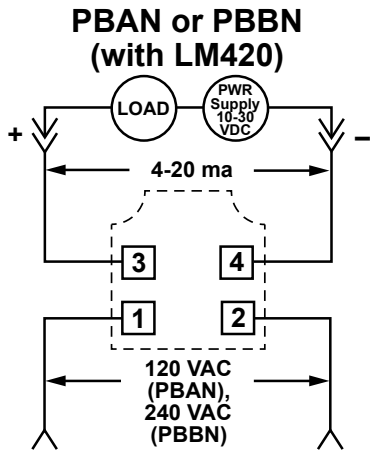

Figure 4. Wiring for PBDN with LM420 (DC Power Block)

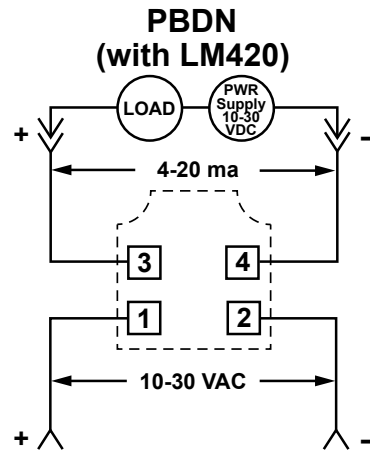
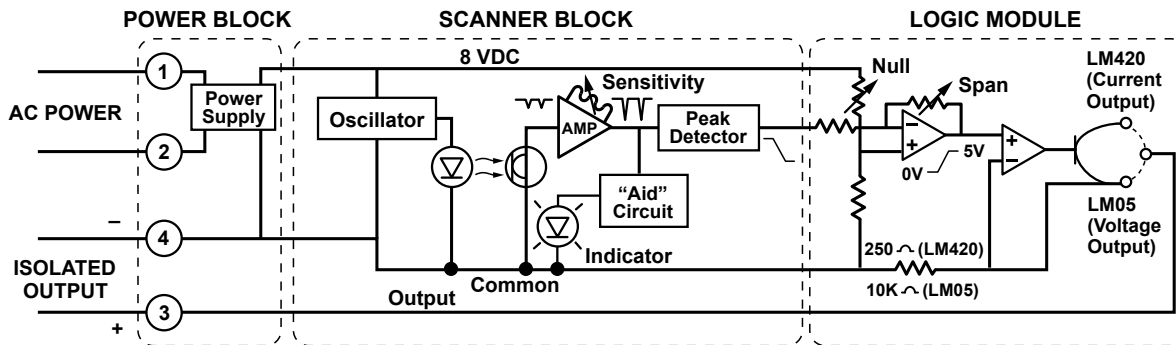

Table 1: Voltage and maximum load resistance for the LM420 logic modules only.

Power Supply Voltage	Maximum Load Resistance
10	100
15	350
24	800
30	110

This table applies to LM420 Logic Modules only (used with AC or DC Power Blocks). These modules use a current source provided by the customer.

Figure 5. Functional schematic



## Null and Span Adjustments

Although all factory-assembled analog MULTI-BEAM units come from the factory with pre-set null (low end) and span (high end) adjustments, it may be necessary to know how to adjust these in the field if the analog units are assembled by the customer.

Assuming the scanner is installed, perform the following adjustments.

If using the LMO5:

1. With no signal being received, set null adjustment for a minimum output (close to zero volts) using a voltmeter.
2. With a maximum signal being received, set the span adjustment for a maximum output (5 volts).
3. Repeat previous steps one or two more times until the desired range is achieved.

If using the LM420:

1. With no signal being received, set null adjustment for minimum output (close to 4 mA) using a current reading meter.
2. With a maximum signal being received, set the span adjustment for a maximum output (20 mA).
3. Repeat previous steps one or two more times until the desired range is achieved.

## Specifications

### Supply Voltage

120 VAC (PBAN), 240 VAC (PBBN), and 10-30 VDC (PBDN)

### Output Rating

LM05 provides a DC voltage output that varies from 0 to 5 VDC as the strength of the photoelectric signal increases from zero to maximum; the load impedance must be 1,000 ohms or greater

LM420 provides a 4 to 20 milliamp current sink, also increasing with increased signal strength (LM420 does not PROVIDE, but rather CONTROLS the current; the source of the current must be provided by the customer)

The AC power block outputs are electrically isolated from the line; the PBDN output is common to the negative side of the supply voltage

### Sensitivity Adjustment

Multi-turn adjustment accessible at top of scanner--turn clockwise to increase sensitivity, counterclockwise to decrease sensitivity

### Other Adjustments

Factory pre-set null and span trim adjustments are located on the logic modules

### Operating Temperature

-40 °C to +70 °C (-40 °F to +158 °F)

### Environmental Rating

NEMA 1, 2, 3, 3S, 4, 4X, 12, and 13

### Light Source

Solid state LED; 880 or 940 nanometers for infrared units; all are modulated for ambient light rejection

### Indicator LED

Red indicator flashes at a rate directly proportional to the signal strength of the light being received

### Construction

Reinforced Valox housing with component encapsulated; molded acrylic lenses

### Conduit Entrance

1/2-14 NPS thread (for use with flexible conduit only)

## Performance Curves

The response curves for the analog scanner blocks differ from excess gain curves only in that the vertical scale is in volts DC (instead of excess gain). The curves here are intended to show the general behavior of each of the analog Scanner Blocks; the actual response curve of the installed scanner may lie above or below the illustrated curves, depending on the settings of its trim adjustment potentiometers.

Notice that each of the curves is somewhat non-linear; this is due to the optics employed in each case. If highly linear response is necessary, the wide-angle retroreflective Scanner Block SBL5W is recommended, along with one or more of the linear reflectors. The beam of the SBL5W is a line of light whose length is approximately 1/3 the distance to the reflector (thus it is 2 inches long at a distance of 6 inches, 6 inches long at a distance of 18 inches, etc.). The width of the line is less than 1/4 inch at a distance of 36 inches.

The other Scanner Blocks are all shown operating in the proximity mode (although the SBF5 may be used in all scanning modes, with suitable Banner fibers).

The primary differences in performance are optical, and due to different lens assemblies; selection depends on the application range requirements.

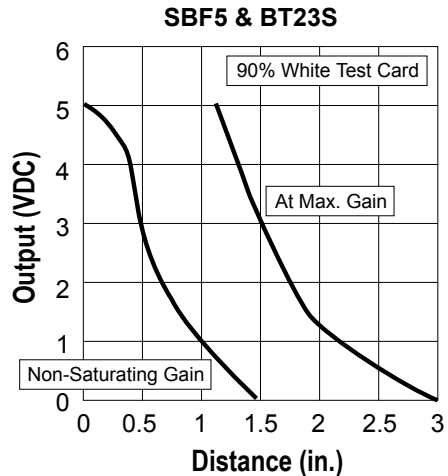
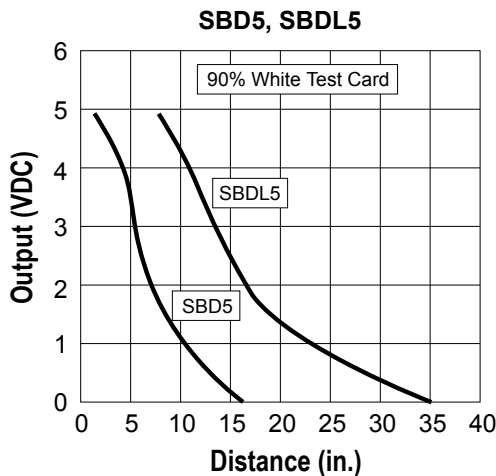

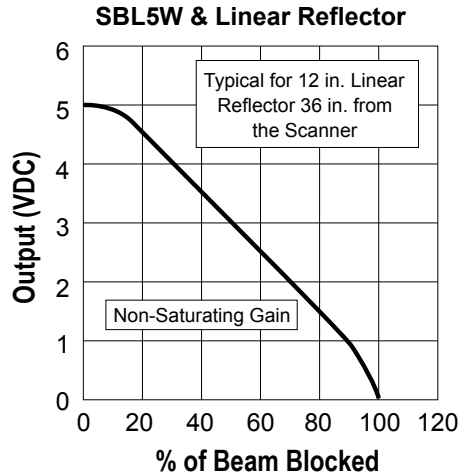
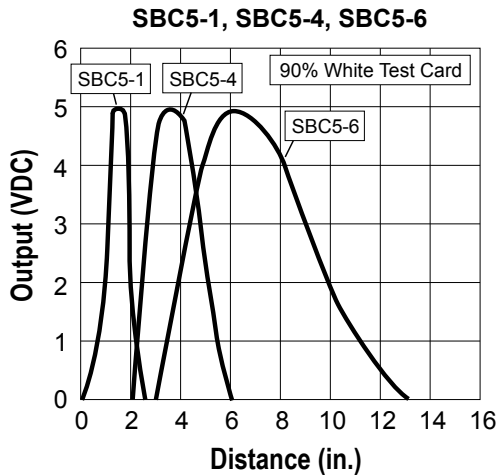

### Dimensions

All measurements are listed in millimeters [inches], unless noted otherwise.

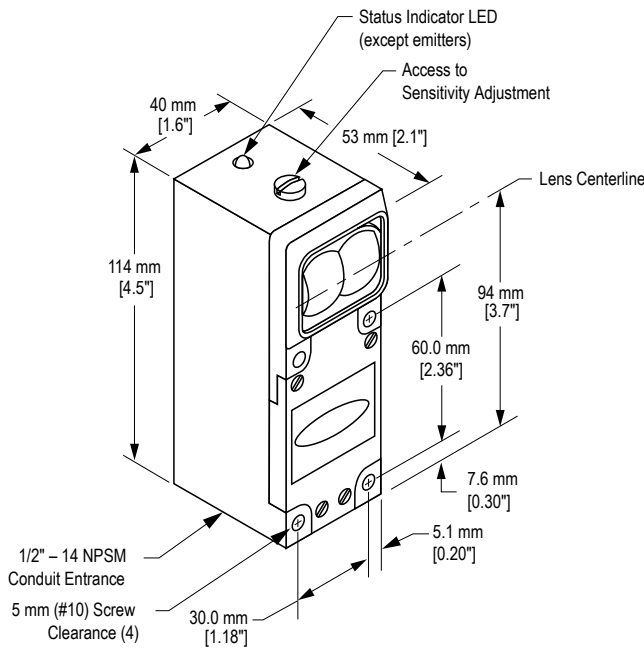

### Banner Engineering Corp. Limited Warranty

Banner Engineering Corp. warrants its products to be free from defects in material and workmanship for one year following the date of shipment. Banner Engineering Corp. will repair or replace, free of charge, any product of its manufacture which, at the time it is returned to the factory, is found to have been defective during the warranty period. This warranty does not cover damage or liability for misuse, abuse, or the improper application or installation of the Banner product.

**THIS LIMITED WARRANTY IS EXCLUSIVE AND IN LIEU OF ALL OTHER WARRANTIES WHETHER EXPRESS OR IMPLIED (INCLUDING, WITHOUT LIMITATION, ANY WARRANTY OF MERCHANTABILITY OR FITNESS FOR A PARTICULAR PURPOSE), AND WHETHER ARISING UNDER COURSE OF PERFORMANCE, COURSE OF DEALING OR TRADE USAGE.**

This Warranty is exclusive and limited to repair or, at the discretion of Banner Engineering Corp., replacement. **IN NO EVENT SHALL BANNER ENGINEERING CORP. BE LIABLE TO BUYER OR ANY OTHER PERSON OR ENTITY FOR ANY EXTRA COSTS, EXPENSES, LOSSES, LOSS OF PROFITS, OR ANY INCIDENTAL, CONSEQUENTIAL OR SPECIAL DAMAGES RESULTING FROM ANY PRODUCT DEFECT OR FROM THE USE OR INABILITY TO USE THE PRODUCT, WHETHER ARISING IN CONTRACT OR WARRANTY, STATUTE, TORT, STRICT LIABILITY, NEGLIGENCE, OR OTHERWISE.**

Banner Engineering Corp. reserves the right to change, modify or improve the design of the product without assuming any obligations or liabilities relating to any product previously manufactured by Banner Engineering Corp. Any misuse, abuse, or improper application or installation of this product or use of the product for personal protection applications when the product is identified as not intended for such purposes will void the product warranty. Any modifications to this product without prior express approval by Banner Engineering Corp will void the product warranties. All specifications published in this document are subject to change; Banner reserves the right to modify product specifications or update documentation at any time. Specifications and product information in English supersede that which is provided in any other language. For the most recent version of any documentation, refer to: [www.bannerengineering.com](http://www.bannerengineering.com).

For patent information, see [www.bannerengineering.com/patents](http://www.bannerengineering.com/patents).